

*The complete camera solution available in a variety of configurations and can be installed anywhere on Cascade attachments.*

Catalog Order No.	Description	Features
6992069	Camera kit composed by Basic camera, Universal camera bracket, Display, Ram Mounting for Display & Camera cable 33ft (10m)*	Video Light
6992067	Camera kit composed by Basic camera, Universal camera bracket, Display, Ram Mounting for Display, Bluetooth transmitter, Battery and Battery charger & cable 6.5ft (2m)	Video Light Tilt indicator Wireless
6992070	Camera kit composed by Sensor camera, Universal camera bracket, Display, Ram Mounting for Display & Camera cable 33ft (10m)*	Video Light Distance Indicator Tilt Indicator
6992064	Camera kit composed by Sensor camera, Universal camera bracket, Display, Ram Mounting for Display, Bluetooth transmitter, Battery and Battery charger & cable 6.5ft (2m)	Video Light Distance Indicator Tilt Indicator Wireless

- ▶ Camera Kits with auxiliary camera available – Consult Cascade.
- ▶ Camera Kits display require 9-48 volt truck power supply. Other voltages upon request.
- ▶ \*Camera cables, when installed through the mast, need a cable pulley kit to allow installation (not included).

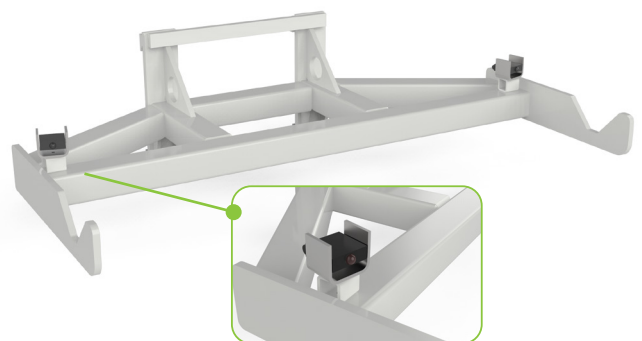
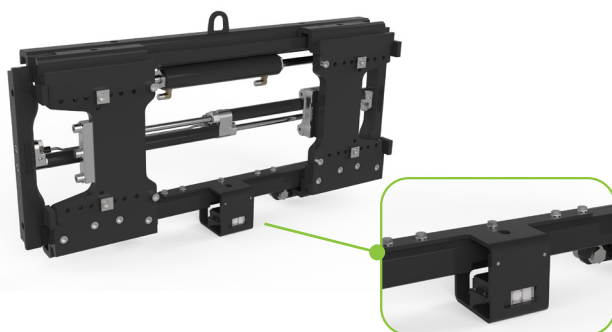

<b>SPECIFICATIONS</b>		
<b>Display</b>	Power Supply	9-48 VDC/2A
	Screen Size	7" (178mm)
	Resolution	1280 x 800px
	Display Dimensions (WxHxT)	8.6" x 5.9" x 2.4" (220mm x 150mm x 62mm)
<b>Primary Camera</b>	Horizontal Field of View	36 degrees
	Power supply	Battery (WiFi) or cable to display
	Mounting	flange for machined fork tip or alternate mounting
	Resolution	2MP
<b>Auxiliary Camera</b>	Horizontal Field of View	130 degrees
	Power supply	Cable to Display
	Dimensions	1.7" x 3.3" x 2.7" (44 x 84 x 68mm)
	Resolution	2MP
<b>Battery Powered Camera System</b>	Communication	Wireless
	Battery Voltage	15V Li-Ion battery pack
	Operating Time	~12 hours continuous use
<b>Powered by the Truck Camera System</b>	Communication	Interconnect to Display using CAT5e min Ethernet cable - Weipu 8pin connectors
<b>Environmental</b>	Temperature	32°F to 104°F Operating (0°C to 40°C) -4°F to 140°F Storage (-20 to 60°C)
	Ingress	IP 67
<b>Software</b>	Update system	Available via WiFi web interface