

U *SER MANUAL*

Manual Reachforks®

Manual Number 6928035-R1



KOOI

Cascade KOOI is a Registered Trademark of Cascade Corporation

Table of Contents

Definitions.....	2
Note	2
Quality Standards, Norms and Directives	2
Safety	3
Identification	4
Assembly	5
Extending	5
Working with Manual Reachforks	6
Maintenance Schedule	6
Wear.....	7
Instructions for Replacement of Sleeve	8
Troubleshooting	8

Definitions



Warning:

Text blocks marked by a “Warning” icon (as shown on the left) and starting with the text “ **Warning:**” provide information on actions which may result in (serious) personal injury.



Caution:

Text blocks marked by a “Caution” icon (as shown on the left) and starting with the text “ **Caution:**” provide information on actions which may result in damage to the Manual Extension Forks, parts of the Manual Extension Forks or goods.

Note

© Copyright 2019, Cascade KOOI, All rights reserved.

Information provided in this manual, including but not limited to illustrations and text, may not be reproduced without the prior written permission of Cascade KOOI.

The information in this manual is provided without any form of guarantee. Under no circumstances shall Cascade KOOI be held liable for accidents or damages arising from the use of this manual.

Please note that information in this manual may be changed at any time without prior notice and that it may contain technical inaccuracies and typing errors. Cascade KOOI makes every effort to avoid errors in this manual, but cannot guarantee this. Please let us know if you encounter any typing errors or technical inaccuracies, or if you have any suggestions.

Other trade or product names used in this manual, but not mentioned here, are the trademarks of their respective holders.

Quality Standards, Norms and Directives

Cascade KOOI complies with the following quality standards: ISO 9001

Manual Reachforks comply with the following norms/directives:

- ISO 13284 - Fork-arm extensions and telescopic fork arms.
- ISO 2328 - Fork-lift trucks - Hook-on type fork arms and fork arm carriages.
- CE (2006/42/EC) – Machinery Directive.
- ISO-FDIS-ISO 3834-2 - Quality requirements for fusion welding of metallic materials - Part 2: Comprehensive quality requirements.

The Manual Reachforks are randomly subjected to dynamic testing in accordance with ISO 2330.

Safety



Warning:
Do not ride on the Manual Reachforks or on the load.



Warning:
Do not walk or stand under the Manual Reachforks.



Warning:
Do not load the Manual Reachforks beyond the limits of the lifting capacities and load center stipulated by the manufacturer.



Warning:
Do not weld anything onto the Manual Reachforks without the express permission of the supplier. Welding carried out without permission shall void any warranty.



Warning:
Do not use faulty Manual Reachforks before they have been either professionally repaired or replaced.



Warning:
Do not use the Manual Reachforks in areas where the temperature is below -30°C (-22°F) unless otherwise agreed with the manufacturer.



Caution:
When leaving the forklift truck, the engine must be switched off and the handbrake applied.



Caution:
Bear in mind the space above and below the Manual Reachforks.



Caution:
The load on the Manual Reachforks must be distributed as evenly as possible.



Caution:
Retract the (loaded) Manual Reachforks as soon as possible.



Caution:
If possible, retract the Manual Reachforks before driving.













Caution:
Always drive with the Manual Reachforks in the lowest possible position.



Caution:
Move hands outside outer sleeves after disengaging locking pin and before sliding outer sleeve inwards.

Identification

Type plate legend:

	Type Description		Weight
	Serial Number		Max. Capacity on Retracted Load Center
	Retracted Center of Gravity		Max. Capacity on Extended Load Center
	Extended Center of Gravity		
	Retracted Load Center		Production Year
	Extended Load Center		Extra Information



Warning: Never exceed the maximum truck capacity as seen on the truck type plate. Rated capacity of both truck and attachment is the responsibility of the original truck manufacturer and may be less than the capacity shown on the attachments type plate.

Structure of Manual Reachforks type description

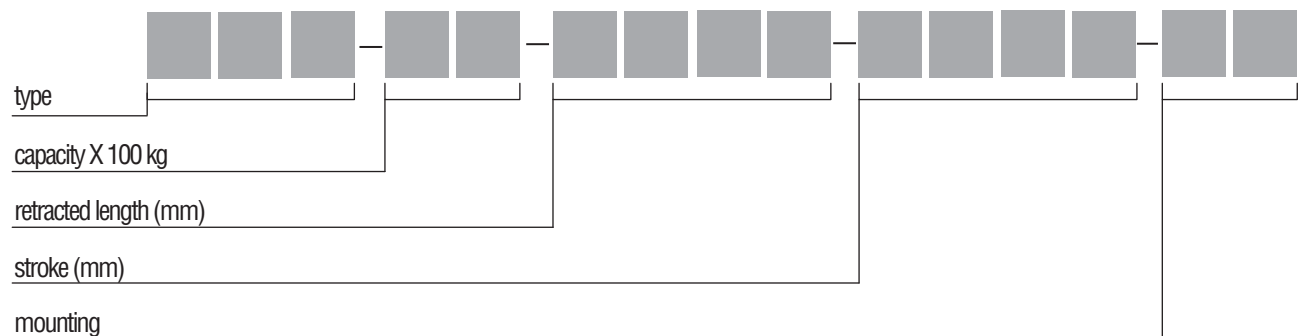

Assembly

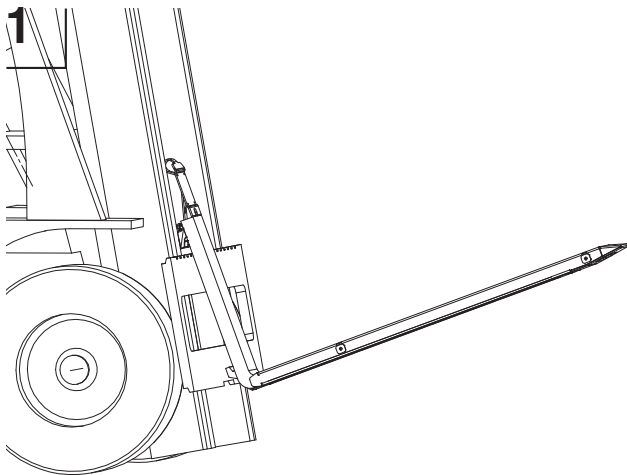

Slide the Manual Reachforks onto the carriage plate.

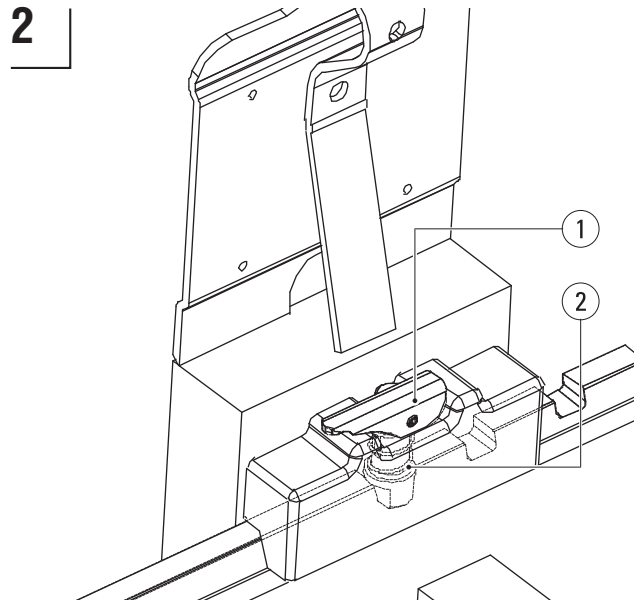

Make sure that locking pin (2) of each Manual Reachfork drops into one of the notches on the carriage plate. Use catch (1) before operating.

Extending

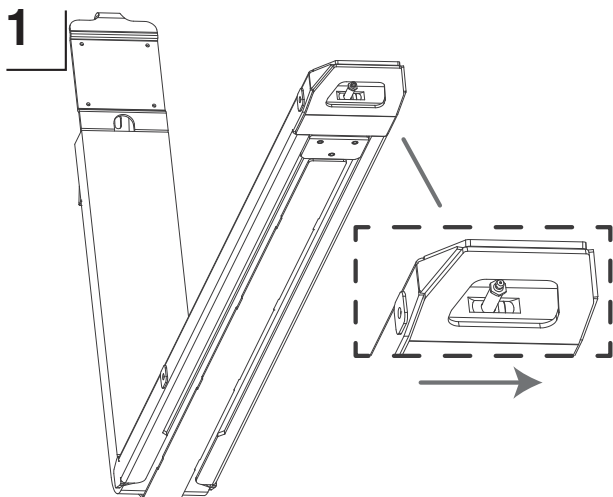

Unlock the fork by moving the catch to the right.

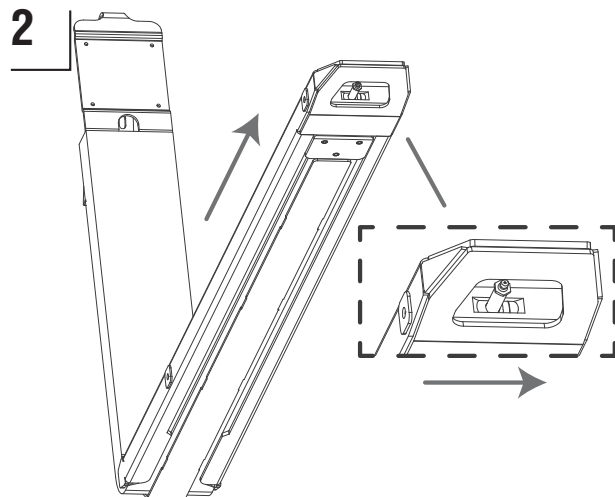

Keep the catch in the right position and pull the fork out a few centimetres. Let go of the catch and pull the sleeve to the next position, where it is secured by the spring mechanism.

Caution! check whether the sleeve is properly secured by pulling/pushing the sleeve once.

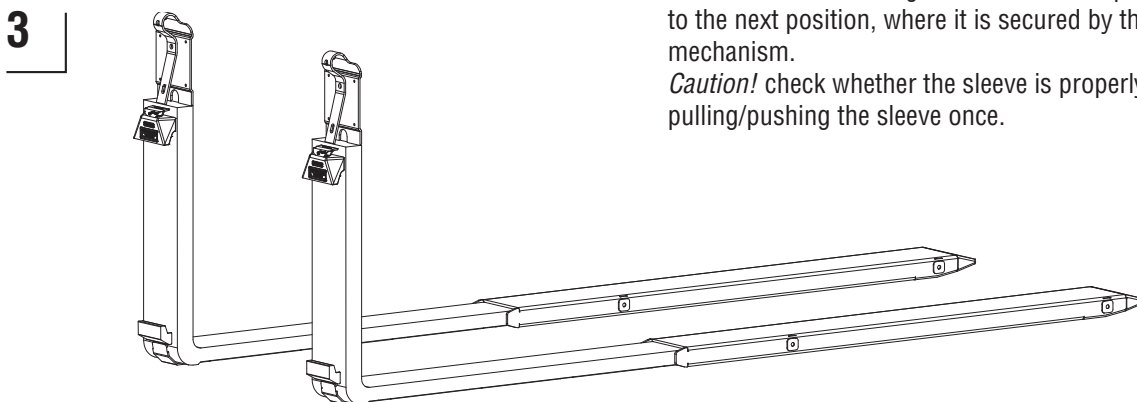





Working with Manual Reachforks

To minimise wear, avoid as much as possible allowing the Manual Reachforks to come into contact with the ground during operation. In order to reduce wear:

- The chains in the mast of the forklift truck can be shortened so that the Manual Reachforks cannot reach the ground.

Maintenance Schedule

N°	Description	Weekly	Monthly	6 months or every 1000 hours	Annually or every 2000 hours
1.	Grease the underside and topside of the inner fork				
2.	Check sleeve for signs of wear, especially the heel side*				
3.	Check for and remove any dirt in the sleeve				
4.	Check inner forks in accordance with ISO 5057* standards				

*See chapter on 'Wear'.

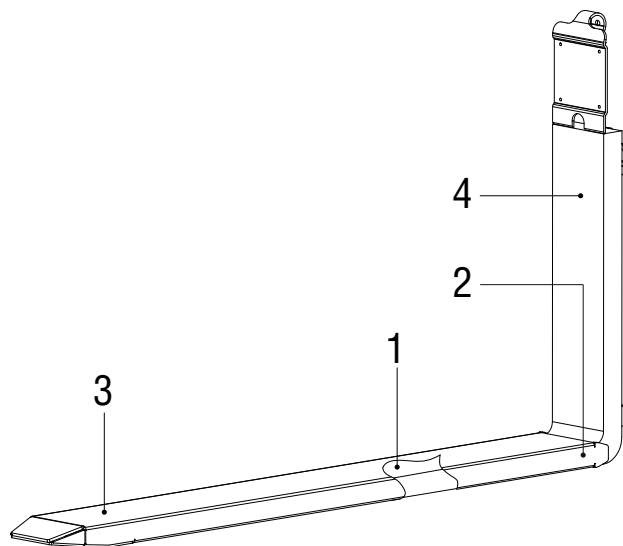

Notes on 'Maintenance Schedule'

- Recommended lubricating grease: Novatex EP2 (point 1).
- If defects are detected, first solve the problem/replace parts before proceeding to work with the Manual Reachforks.
- See chapter on 'Instructions for Replacement of Sleeve' for further explanation about replacing the sleeve.

Wear

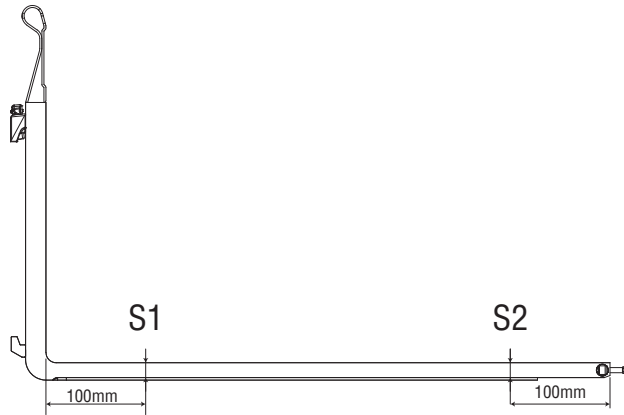
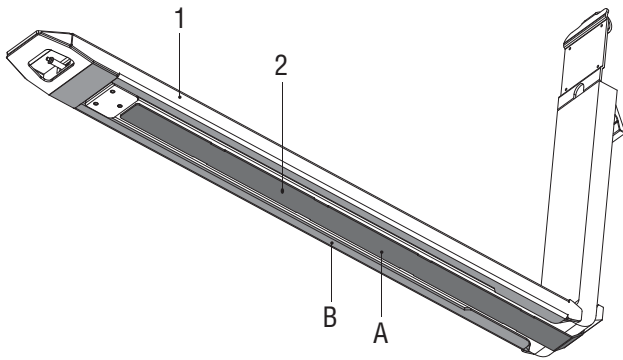

When surface A (dark grey) is worn to the extent that it is level with or below surface B (light grey), then the wear plate (2) must be replaced. If there are signs of wear on the lower side of the sleeve (2) then it must also be replaced. See point 4 of the Maintenance Schedule.

The inner fork is declared unfit for use and must be replaced when S1 is 5% thinner than S2. See point 4 of the Maintenance Schedule.

Wear Plate Welding Data:

- Process: MAG (135), 210A, 28 VDC
- Weld type: fillet weld a4, 1 layer
- Cleaning: brush
- Wire: 1 mm, EN 12534 / Mn3Ni1CrMo
- Shielding gas: 80% Ar / 20% CO₂, 15-16 L/min
- Weld in wear plate notches

Caution:



The sleeves must be removed from the Manual Reachforks before welding work on the sleeves can proceed.

Instructions for Replacement of Sleeve

- 1 Position the Manual Reachforks at hip height, tilt the mast of the forklift truck slightly forward.

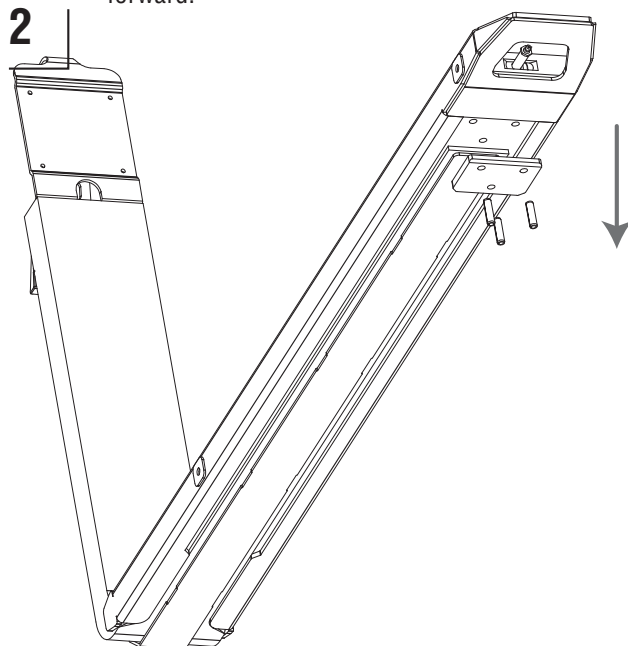

Remove the stop using the three clamping bushes that connect it to the inner fork.

3

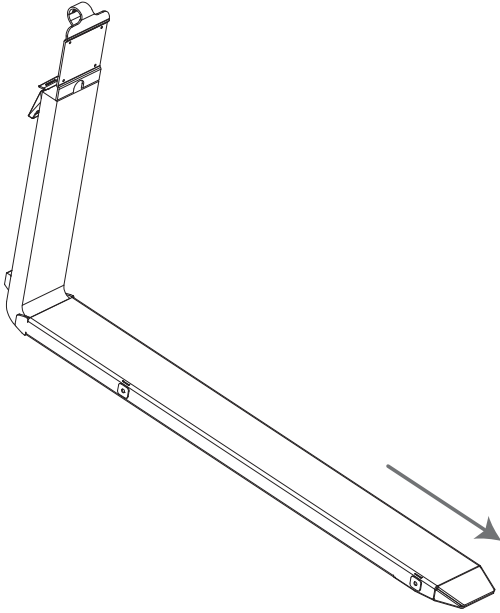

Unlock the fork by moving the catch to the right and slide the sleeve off the fork.

4

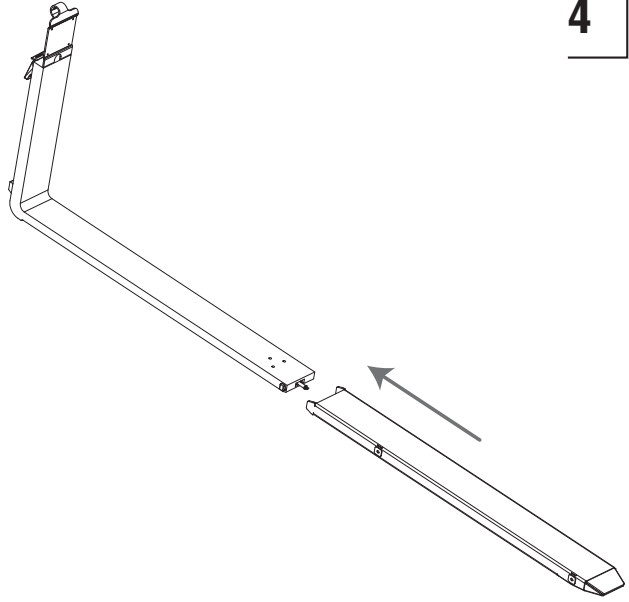

Slide the catch to the right, similar to the unlocking procedure. Slide the sleeve back around the fork and replace the stop.

Troubleshooting

Observation	Symptom	Possible Cause	Possible Solution
Difference in height between forks	One fork point is hanging lower than the other	One of the Manual Extension Forks has been permanently deformed as a result of overloading	Remove the forks from the carriage plate immediately and contact the supplier
		One of the Manual Extension Forks is not hanging properly on the carriage plate	Hang the Manual Extension Forks properly onto the carriage plate (check locking mechanism)
		Carriage plate is not completely horizontal	Please contact your forklift truck supplier
		The forks do not match (forks belong to different sets)	Check the serial numbers
Excessive play between fork blade and sleeve		Wear strips on one Manual Extension Fork are more worn than the other	Replace wear strips
		Wear strips worn out	
		Sleeves worn out	Replace sleeves

Do you have questions you need answered right now? Call your nearest Cascade KOOI Service Department. Visit us online at www.cascorp.com

AMERICAS

Cascade KOOI U.S. Headquarters

2201 NE 201st
Fairview, OR 97024-9718
Tel: 800-CASCADE (227-2233)
Fax: 888-329-8207

Cascade KOOI Canada Inc.

5570 Timberlea Blvd.
Mississauga, Ontario
Canada L4W-4M6
Tel: 905-629-7777
Fax: 905-629-7785

Cascade KOOI do Brasil

Praça Salvador Rosa,
131/141-Jordanópolis,
São Bernardo do Campo - SP
CEP 09891-430
Tel: 55-13-2105-8800
Fax: 55-13-2105-8899

