



# Technical Bulletin

## Servicing J-Carton Clamp Replaceable (Talon) Pallet Pad Assemblies

Cascade's J-Carton Clamp Talon Pallet Pad Assembly option provides reduced contact pad maintenance for pallet handling applications. The pad segments can be individually rotated, repositioned or replaced for continued secure load handling. Service procedures are quick and easy. Parts breakdown information is included.

- 1 Inspect the pad segments to determine if they can be repositioned, rotated or need to be replaced.
- 2 Remove the capscrews fastening a two hole or three hole retainer bar on one side of the pad segment(s) being serviced. **Do not remove the four hole retainer bars that fasten the backing plate to the arm stabilizer.** Reposition, rotate or replace the pad segment as required.
- 3 Reinstall the retainer bar. Tighten the M8 capscrews to a torque of 19 ft.-lbs. (26 Nm). Tighten the M12 capscrews to a torque of 48 ft.-lbs. (65 Nm).

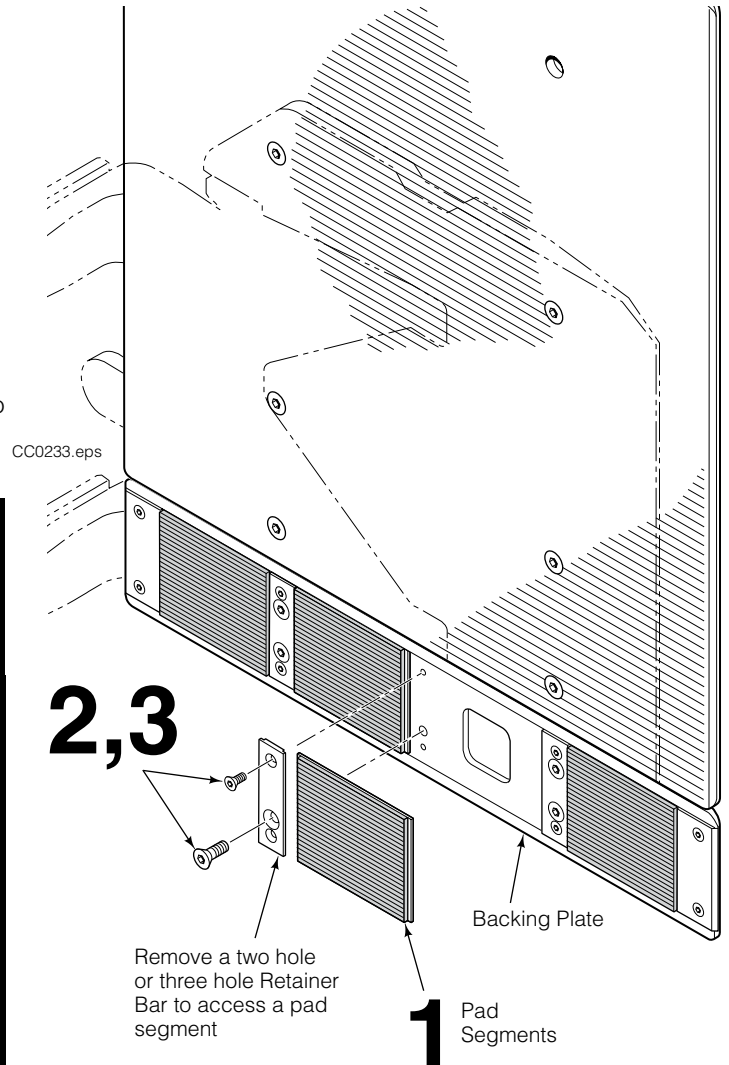
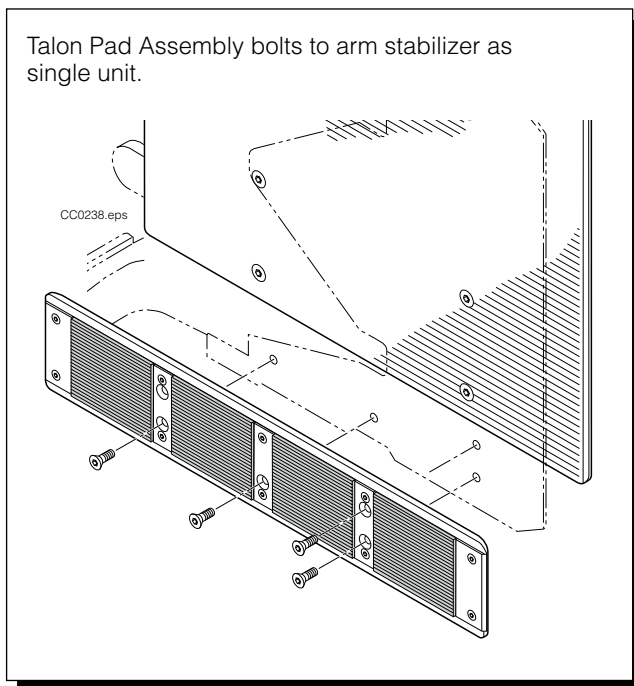

**cascade**<sup>®</sup>  
**corporation**

**For Technical Support . . .**

Call: 1-800-227-2233 Fax: 1-888-329-8207

Internet: [www.cascorp.com](http://www.cascorp.com)

Write: Cascade Corporation, PO Box 20187, Portland, OR 97294

**To Order Parts . . .**

Call: 1-888-227-2233 Fax: 1-888-329-0234

Internet: [www.cascorp.com](http://www.cascorp.com)

Write: Cascade Corporation, 2501 Sheridan Ave., Springfield, OH 45505

# Talon Pallet Pad Assembly Parts

REF	QTY	40 in. Pad Length PART NO.	42 in. Pad Length PART NO.	DESCRIPTION
		6907684	6908263	Pallet Pad Assembly
1	1	6907683	6908262	Backing Plate
2	2	6900080	6900080	End Bar
3	2	6907681	6907400	Retainer Bar
4	4	6405876	6405876	Capscrew, M8 x 12
5	6	6405877	6405877	Capscrew, M8 x 14
6	1	6907682	6907682	Retainer Bar
7	2	6900082	6908261	Wear Strip
8	2	6900082	6900082	Wear Strip

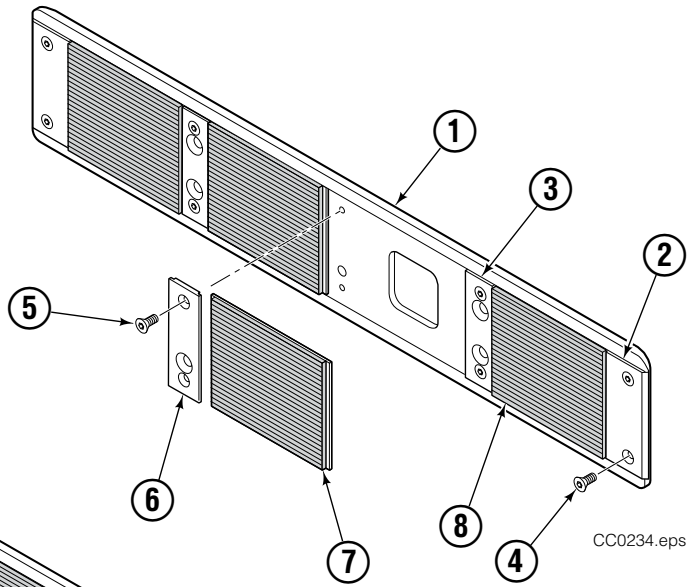

REF	QTY	48 in. Pad Length PART NO.	52 in. Pad Length PART NO.	54 in. Pad Length PART NO.	DESCRIPTION
		6900083	6908313	6908272	Pallet Pad Assembly
1	1	6900078	6908312	6908271	Backing Plate
2	2	6900080	6900080	6900080	End Bar
3	2	6907400	6908310	6908582	Retainer Bar
4	4	6405876	6405876	6405876	Capscrew, M8 x 12
5	8	6405877	6405877	6405877	Capscrew, M8 x 14
6	2	6900084	6908309	6908583	Retainer Bar
7	3	6900082	6908261	6908261	Wear Strip
8	2	6900082	6900082	6900082	Wear Strip

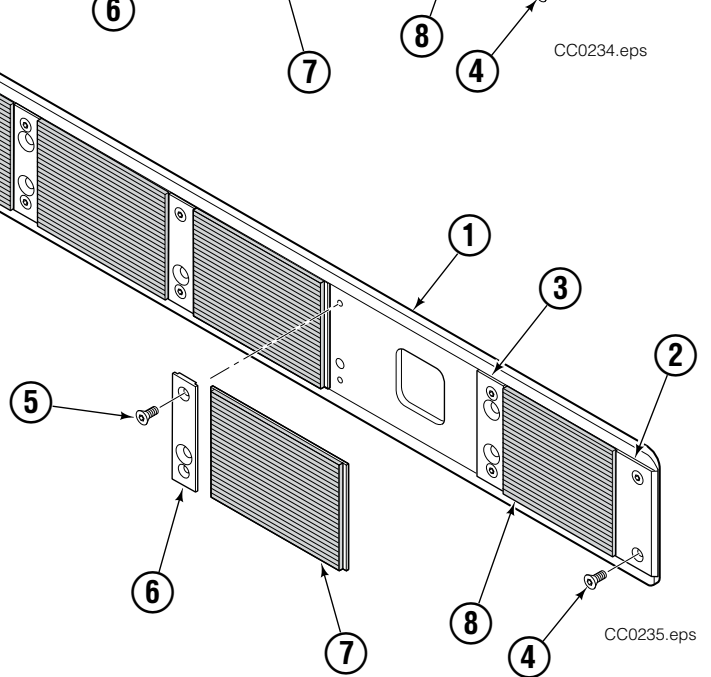

REF	QTY	60 in. Pad Length PART NO.	DESCRIPTION
		6908290	Pallet Pad Assembly
1	1	6908289	Backing Plate
2	2	6908270	End Bar
3	2	6907681	Retainer Bar
4	4	6405876	Capscrew, M8 x 12
5	10	6405877	Capscrew, M8 x 14
6	3	6907682	Retainer Bar
7	4	6900082	Wear Strip
8	2	6908261	Wear Strip

