

OPERATOR'S GUIDE

Rotators & Bin Retainer

Manual No. 672714-R4

**cascade[®]
corporation**

Cascade is a Registered Trademark of Cascade Corporation

C ONTENTS

Introduction	<i>i</i>
Safety Rules	1
Daily Inspection	3
Fork Installation	4
Attachment Operation	5
Load Handling	6
Pickup and Transport	6
Rotating	7
Rotator with Bin Retainer	8
Safe Operation and Maintenance	9
OSHA Regulations	9



WARNING: Rated capacity of the truck/attachment combination is a responsibility of the original truck manufacturer and may be less than shown on the attachment nameplate. Consult the truck nameplate.

WARNING: Do not operate this attachment unless you are a trained and authorized lift truck driver.

CAUTION: This guide shows load handling procedures for most products. Ask your company or organization about any special procedures for the loads you may be handling.

INTRODUCTION

Rotators – Cascade Rotators are designed to tip and dump a wide variety of fork loads.

About this Guide – This guide is prepared to simplify your understanding about efficient and safe Rotator use and operation. Please read the guide thoroughly before operating the attachment. Be sure you know and understand all operating procedures and safety precautions. If you have any questions, or don't understand a procedure, ask your supervisor.

Emphasize Safety! Most accidents are caused by operator carelessness or misjudgement. You must watch for hazardous situations and correct them.

180° Rotation

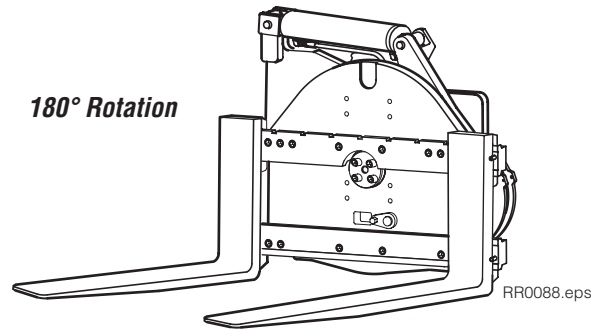

RR0088.eps

360° Rotation

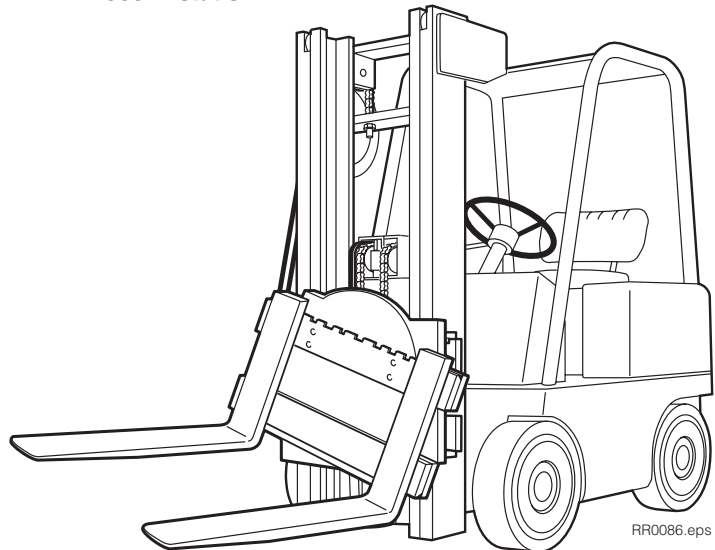

RR0086.eps

360° Rotation with Bin Retainer

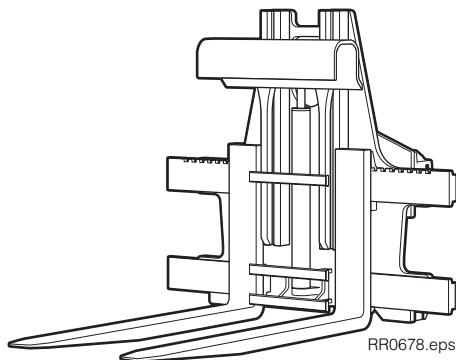

RR0678.eps

S SAFETY RULES

Industrial Lift Trucks

No riders



No reaching through mast



No standing under load



RR0070.eps

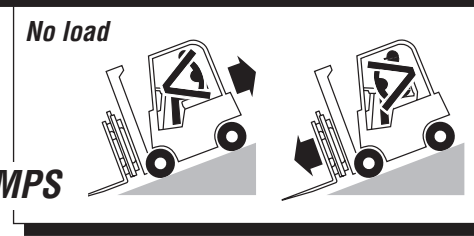
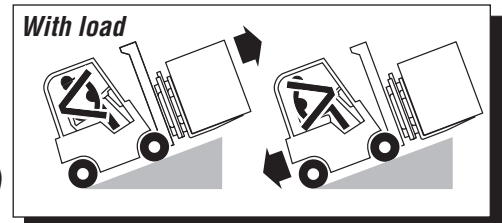
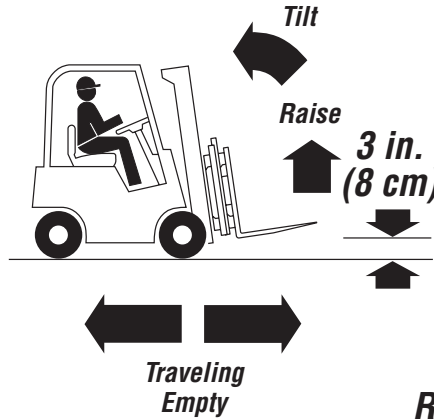

RR0071.eps

<p>TRAFFIC</p> <p>Observe</p> <p>Workers</p> <p>Stops</p>			<p>Slow for two way traffic</p>	<p>Sound horn, slow at intersection</p>	<p>Sound horn, slow at corner</p>
<p>Wet floors</p>	<p>Bumps</p>	<p>Dips</p>			

S SAFETY RULES

Handling loads

Do not rotate in immediate vicinity of other people.



Limit truck movement with raised load.

Top of load must not extend above frame.

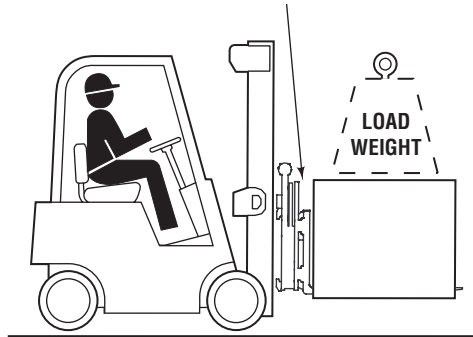

Load weight must not exceed combined truck/attachment capacity (see truck nameplate).

Total fork capacity (LH + RH fork) must be greater than load weight. Check capacity stamp on forks.

Rotate elevated loads slowly.

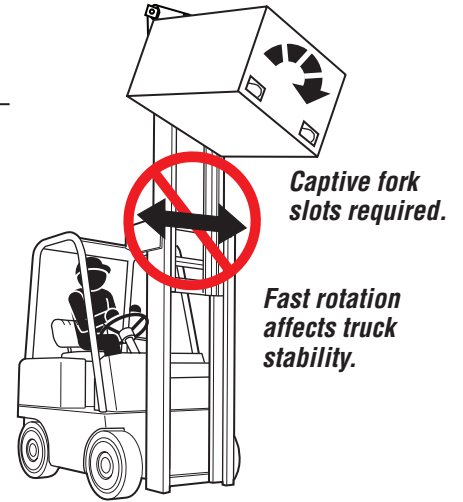

Captive fork slots required.

Fast rotation affects truck stability.

RR0089.eps

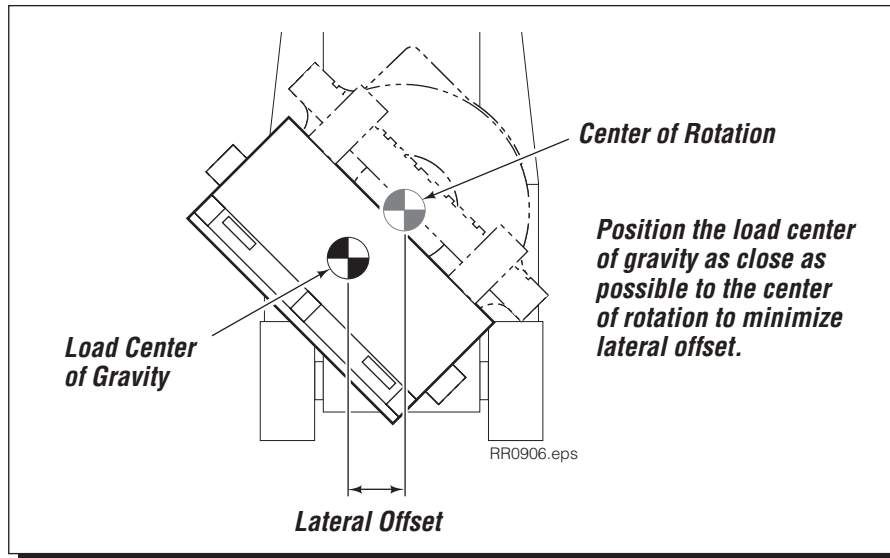

DAILY INSPECTION

Check items each day. Report problems to your supervisor. See the Service Manual for maintenance and repair procedures.

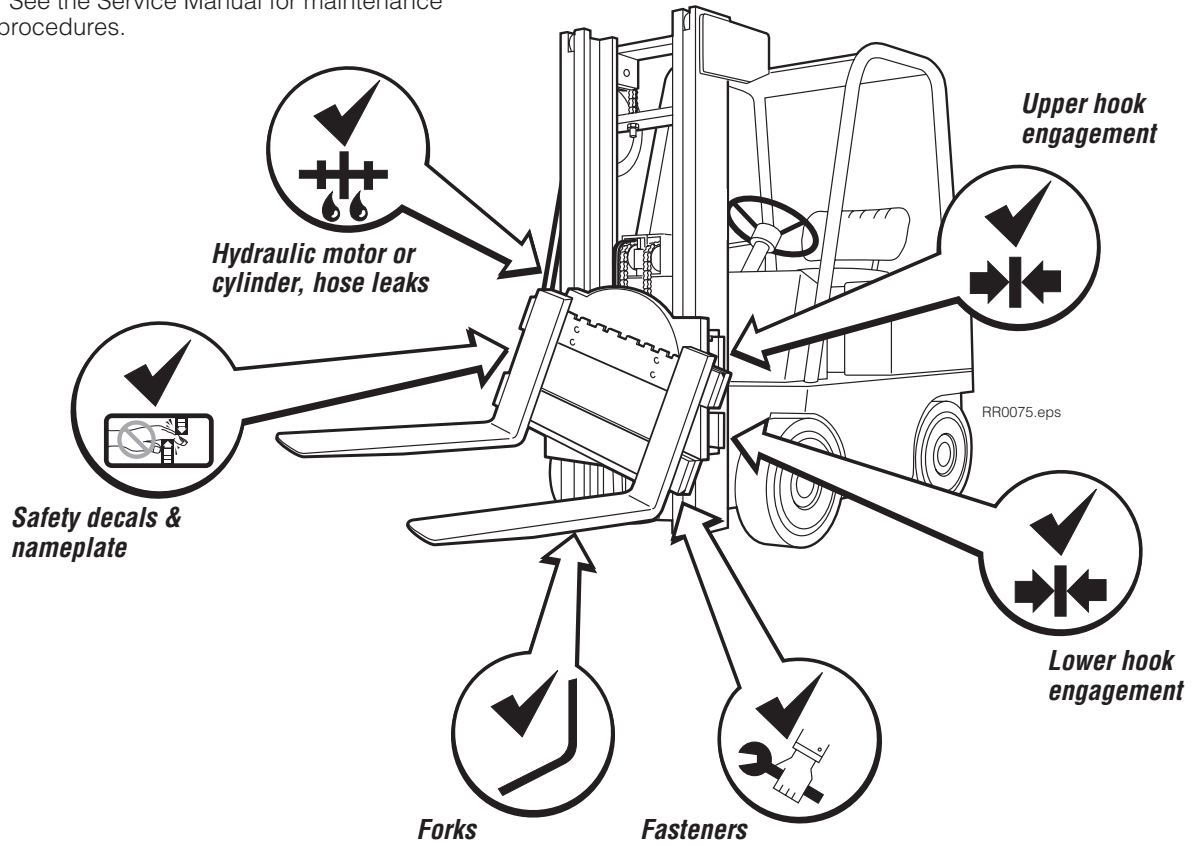

FORK INSTALLATION

INSTALL, POSITION and LOCK FORKS

Lever Type Fork Lock

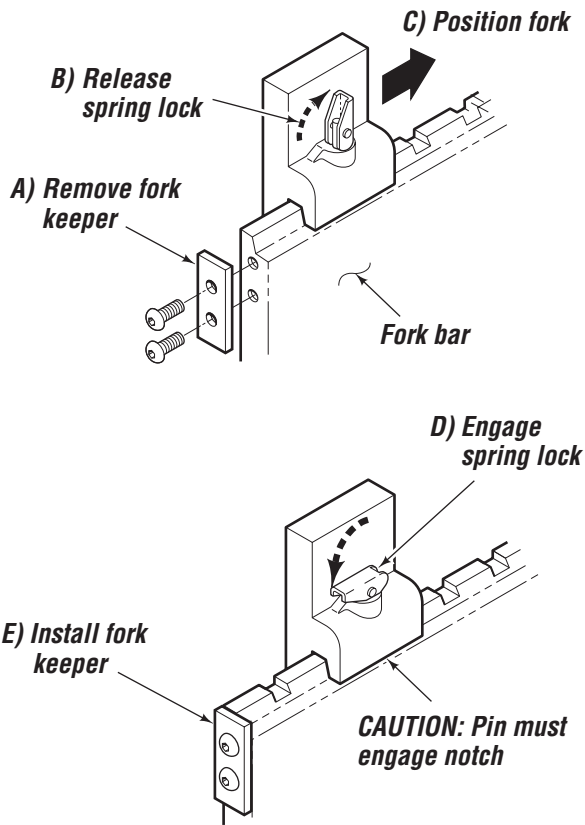

Twist Type Fork Lock

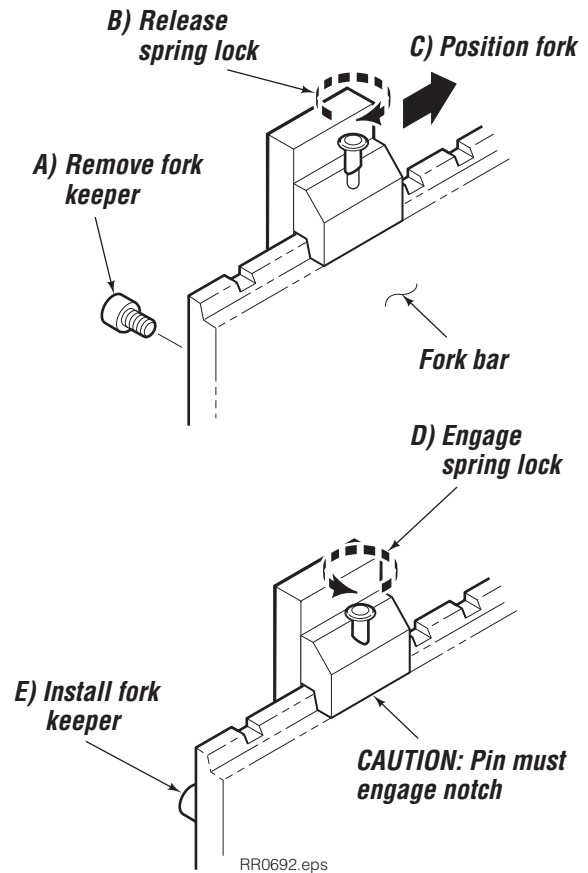

WARNING: Handle forks with care to avoid pinching fingers or dropping on feet.

Forks must have third hook when used on Rotators

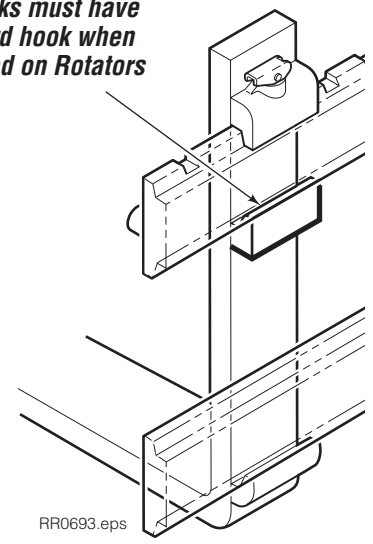
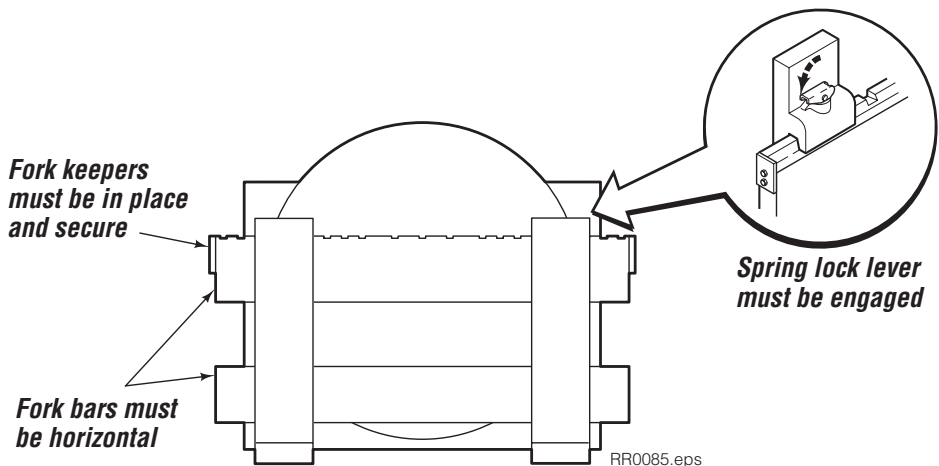

A TTACHMENT OPERATION

ROTATORS

- A** Rotate Counterclockwise (CCW)
- B** Rotate Clockwise (CW)

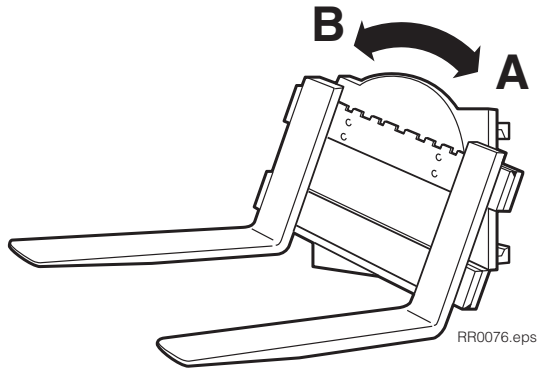

AUXILIARY VALVE FUNCTIONS

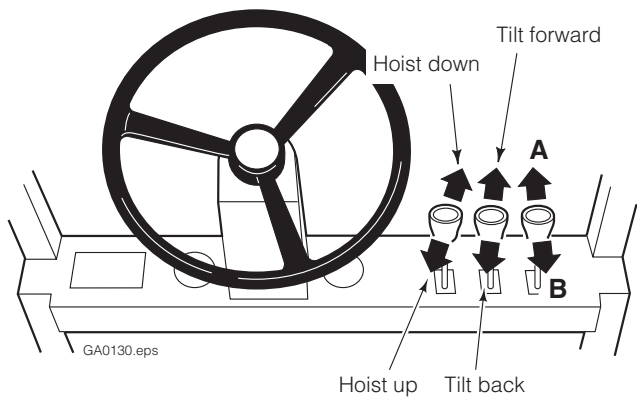

ROTATOR with BIN RETAINER

- A** Rotate Counterclockwise (CCW)
- B** Rotate Clockwise (CW)
- C** Release
- D** Clamp

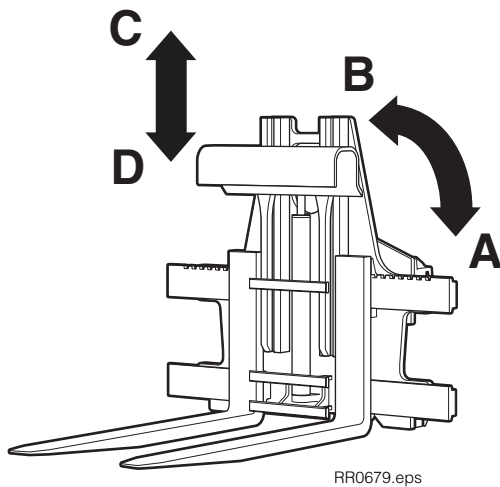

AUXILIARY VALVE FUNCTIONS

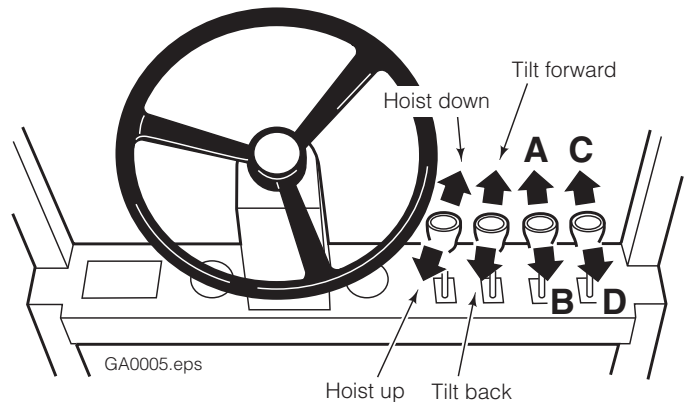

LOAD HANDLING

Pick Up and Transport

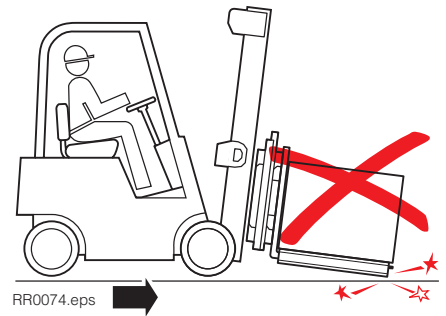
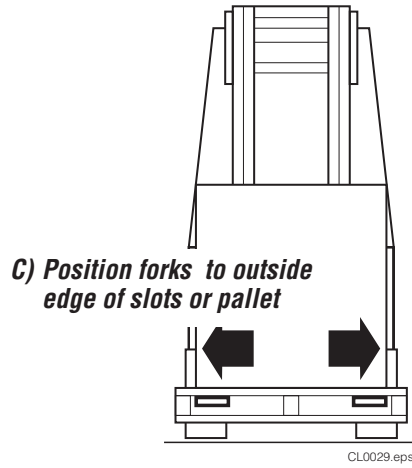
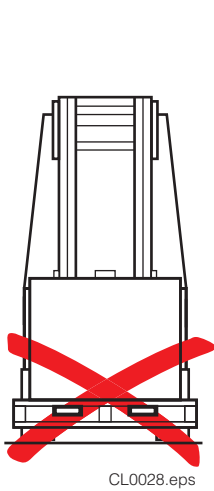
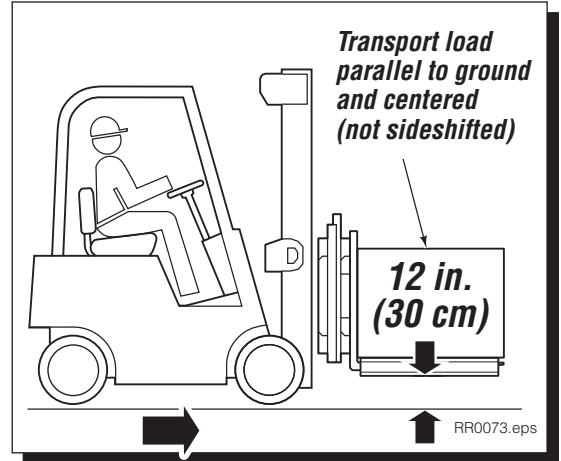
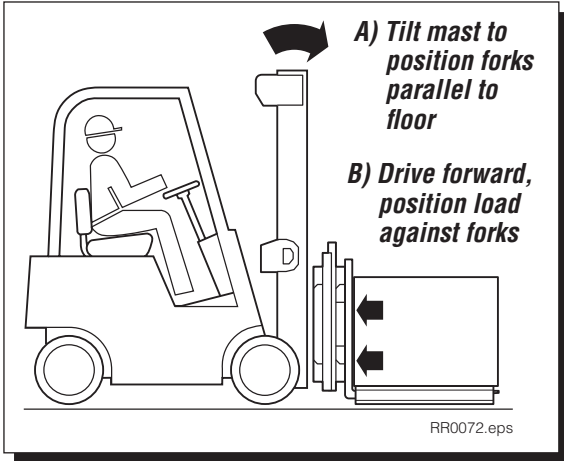

LOAD HANDLING

Rotating

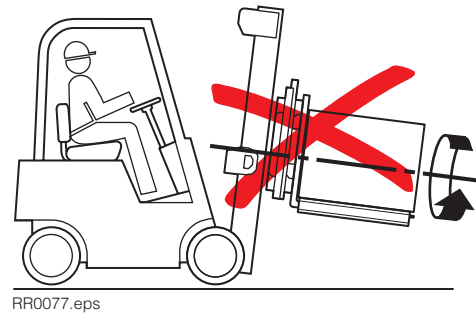
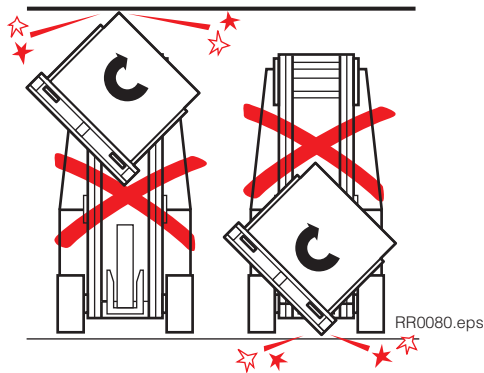
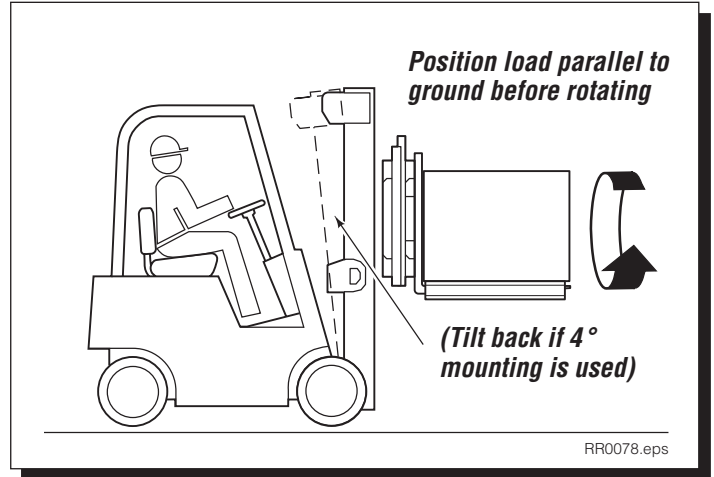
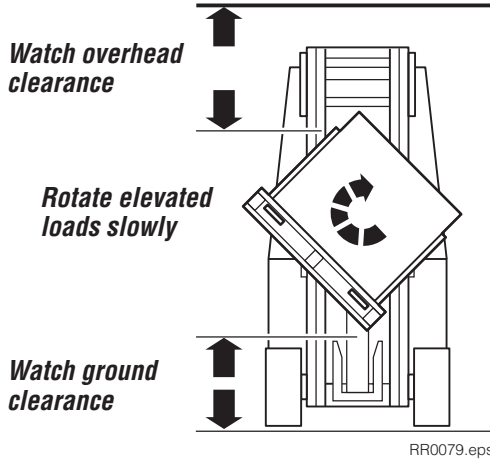

Position the load center of gravity as close as possible to the center of rotation to minimize lateral offset. This will reduce torque requirements and increase truck stability.

IMPORTANT: To make sure your rotator attachment will handle a specific load, refer to your attachment's service manual, "Determining Load Torque Requirements" section.

Center of Rotation

Load Center of Gravity

Lateral Offset

RR0907.eps



LOAD HANDLING

Rotator with Bin Retainer

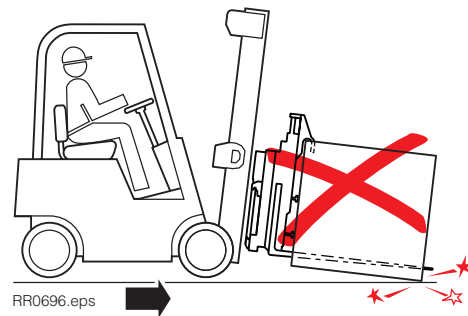
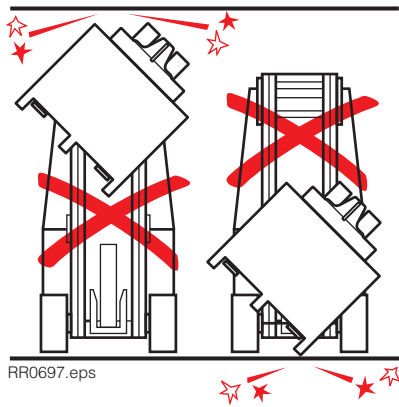
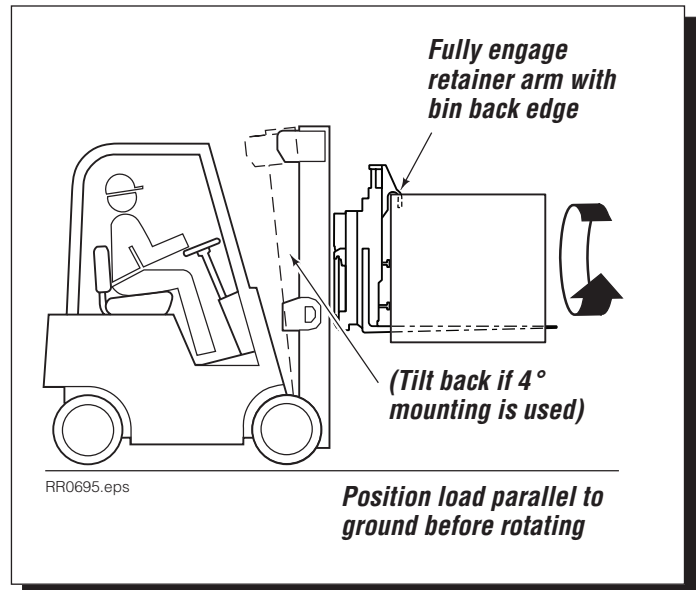
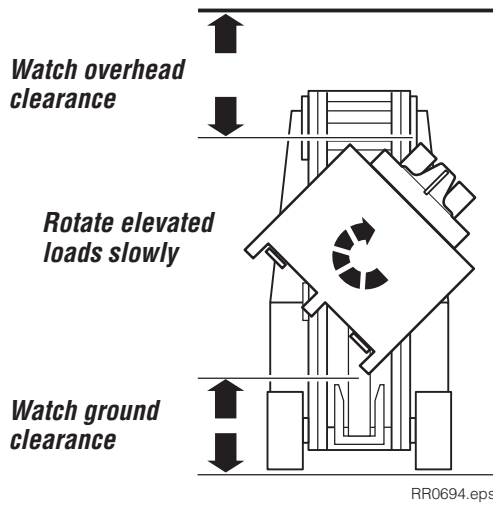



SAFE OPERATION AND MAINTENANCE

OSHA Regulations – Industrial Trucks and Attachments



WARNING: The safe operation and maintenance of industrial trucks is regulated by Occupational Safety and Health (OSHA) regulations 1910.178 and American National Standards Institute (ANSI) Safety Standard for Powered Industrial Trucks, ANSI B56.1. When operating and maintaining industrial trucks equipped with attachments you should pay particular attention to the following sections of these regulations. You should be familiar with **all** sections of these regulations. **Ask your employer for the complete regulations.**

(a) General Requirement

- (4) Modifications and additions which affect capacity and safe operation shall not be performed by the customer or user without manufacturers prior written approval. Capacity, operation and maintenance instruction plates, tags or decals shall be changed accordingly.
- (5) If the truck is equipped with front-end attachments other than factory installed attachments, the user shall request that the truck be marked to identify the attachments and show the appropriate weight of the truck and attachment combination at maximum elevation with load laterally centered.
- (6) The user shall see that all nameplates and markings are in place and maintained in a legible condition.

(e) Safety Guards

- (2) If the type of load presents a hazard, the user shall equip fork trucks with a vertical load backrest extension in accordance with (a)(2) following.

(a)(2) All new powered industrial trucks acquired and used by an employer after February 15, 1972 shall meet the design and construction requirements for powered industrial trucks established in the "American National Standard for Powered Industrial Trucks, Part II, ANSI B56.1", except for vehicles intended primarily for earth moving or over-the-road hauling.

(l) Operator Training

Only trained and authorized operators shall be permitted to operate a powered industrial truck. Methods shall be devised to train operators in the safe operation of powered industrial trucks.

(m) Truck Operations

- (1) Trucks shall not be driven up to anyone standing in front of a bench or other fixed object.
- (2) No person shall be allowed to stand or pass under the elevated portion of any truck, whether loaded or empty.
- (3) Unauthorized personnel shall not be permitted to ride on powered industrial trucks. A safe place to ride shall be provided where riding of trucks is authorized.
- (4) The employer shall prohibit arms or legs from being placed between the uprights of the mast or outside the running lines of the truck.
- (5i) When a powered industrial truck is left unattended, load engaging means shall be fully lowered, controls shall be neutralized, power shall be shut off and brakes set. Wheels shall be blocked if the truck is parked on an incline.
- (5ii) A powered industrial truck is unattended when the operator is 25 feet or more away from the vehicle which remains in his view, or whenever the operator leaves the vehicle and it is not in his view.
- (5iii) When the operator of an industrial truck is dismounted and within 25 feet of the truck still in his view, the load engaging means shall be fully lowered, controls neutralized and the brakes set to prevent movement.

- (6) A safe distance shall be maintained from the edge of ramps or platforms while on any elevated dock or platform or freight car. Trucks shall not be used for opening or closing freight doors.
- (10) A load backrest extension shall be used whenever necessary to minimize the possibility of the load or part of it from falling rearward.

(n) Traveling

- (4) The driver shall be required to slow down and sound the horn at cross isles and other locations where vision is obstructed. If the load being carried obstructs forward view, the driver shall be required to travel with the load trailing.
- (7i) When ascending or descending grades in excess of 10 percent, loaded trucks shall be driven with the load upgrade.
- (7iii) On all grades the load and load engaging means shall be tilted back if applicable, and raised only as far as necessary to clear the road surface.

(o) Loading

- (1) Only stable or safely arranged loads shall be handled. Caution shall be exercised when handling off-center loads which cannot be centered.
- (2) Only loads within the rated capacity of the truck shall be handled.
- (3) The long or high (including multiple-tiered) loads which may affect capacity shall be adjusted.
- (4) Trucks equipped with attachments shall be operated as partially loaded trucks when not handling a load.
- (5) A load engaging means shall be placed under the load as far as possible; the mast shall be carefully tilted backward to stabilize the load.
- (6) Extreme care shall be used when tilting the load forward or backward, particularly when high tiering. Tilting forward with load engaging means elevated shall be prohibited except to pick up a load. An elevated load shall not be tilted forward except when the load is in a deposit position over a rack or stack. When stacking or tiering, only enough backward tilt to stabilize the load shall be used.

(p) Operation of the Truck

- (1) If at any time a powered industrial truck is found to be in need of repair, defective, or in any way unsafe, the truck shall be taken out of service until it has been restored to safe operating condition.

(q) Maintenance of Industrial Trucks

- (1) Any power-operated industrial truck not in safe operating condition shall be removed from service. All repairs shall be made by authorized personnel.
- (5) All parts of any such industrial truck requiring replacement shall be replaced only by parts equivalent as to safety with those used in the original design.
- (6) Industrial trucks shall not be altered so that the relative positions of the various parts are different from what they were when originally received from the manufacturer, nor shall they be altered either by the addition of extra parts not provided by the manufacturer or by the elimination of any parts. Additional counter-weighting of fork trucks shall not be done unless approved by the truck manufacturer.
- (7) Industrial trucks shall be examined before being placed in service and shall not be placed in service if the examination shows any condition adversely affecting the safety of the vehicle. Such examinations shall be made at least daily. When industrial trucks are used on a round-the-clock basis, they shall be examined after each shift. Defects when found shall be immediately reported and corrected.

Do you have questions you need answered right now?

Call your nearest Cascade Service Department.

Visit us online at www.cascorp.com

AMERICAS

**Cascade Corporation
Parts Sales**

2501 Sheridan Ave.
Springfield, OH 45505
Tel: 888-CASCADE (227-2233)
Fax: 888-329-0234

Cascade Canada Inc.

5570 Timberlea Blvd.
Mississauga, Ontario
Canada L4W-4M6
Tel: 905-629-7777
Fax: 905-629-7785

Cascade do Brasil

Praça Salvador Rosa,
131/141-Jordanópolis,
São Bernardo do Campo - SP
CEP 09891-430
Tel: 55-13-2105-8800
Fax: 55-13-2105-8899

EUROPE-AFRICA

**Cascade Italia S.R.L.
European Headquarters**

Via Dell'Artigianato 1
37030 Vago di Lavagno (VR)
Italy
Tel: 39-045-8989111
Fax: 39-045-8989160

Cascade (Africa) Pty. Ltd.

PO Box 625, Isando 1600
60A Steel Road
Sparton, Kempton Park
South Africa
Tel: 27-11-975-9240
Fax: 27-11-394-1147

ASIA-PACIFIC

Cascade Japan Ltd.

2-23, 2-Chome,
Kukuchi Nishimachi
Amagasaki, Hyogo
Japan, 661-0978
Tel: 81-6-6420-9771
Fax: 81-6-6420-9777

Cascade Korea

121B 9L Namdong Ind.
Complex, 691-8 Gojan-Dong
Namdong-Ku
Inchon, Korea
Tel: +82-32-821-2051
Fax: +82-32-821-2055

Cascade-Xiamen

No. 668 Yangguang Rd.
Xinyang Industrial Zone
Haicang, Xiamen City
Fujian Province
P.R. China 361026
Tel: 86-592-651-2500
Fax: 86-592-651-2571

**Cascade India Material
Handling Private Limited**

Office No.21, 3rd Floor,
Lokmanya House,
Plot No.44, Sr. No. 89/90,
CTS No.950,
Lokmanya Colony, Paud Rd.,
Kothrud, Pune-411038
Phone : +91 955 250 3060

Cascade Australia Pty. Ltd.

1445 Ipswich Road
Rocklea, QLD 4107
Australia
Tel: 1-800-227-223
Fax: +61 7 3373-7333

Cascade New Zealand

15 Ra Ora Drive
East Tamaki, Auckland
New Zealand
Tel: +64-9-273-9136
Fax: +64-9-273-9137

**Sunstream Industries
Pte. Ltd.**

18 Tuas South Street 5
Singapore 637796
Tel: +65-6795-7555
Fax: +65-6863-1368

