



Installation Instructions

Conversion to 10 in. (250 mm) Forks for 100K through 150K Fork Positioners. Kit 6179550

This Instruction sheet provides instructions to convert 100K, 120K and 150K Fork Positioners to 10 in. (250 mm) wide forks by installing fork spacers, cylinder rod collars and new capscrews.

- 1 Position fork carriers at mid-stroke and remove inner fork retainers. Remove forks if installed.
- 2 Remove cylinder rod anchor plugs, slide fork carriers inward to expose split-ring keepers (see detail). Remove keepers.
- 3 Slide the fork carriers outward to clear cylinder rods approximately 6 in. (150 mm). Install collars on cylinder rods. **NOTE:** Collars are necessary to prevent over-stroking when closing with 10 in (250 mm) forks.
- 4 Slide fork carriers inward. Reinstall split-ring keepers and anchor plugs. Use grease to hold split-rings in place. Tighten anchor plugs to 50 ft.-lbs. (65 Nm).
- 5 Install 10 in (250 mm) forks. Slide into position on outer fork carriers.
- 6 Install new fork spacer and capscrews. Tighten capscrews to 25 ft.-lbs. (35 Nm).
- 7 Cycle fork positioner several times to test before returning attachment to operation.



WARNING: The total weight of both 10 in. (250 mm) wide forks must not exceed 650 lbs. (295 kg).

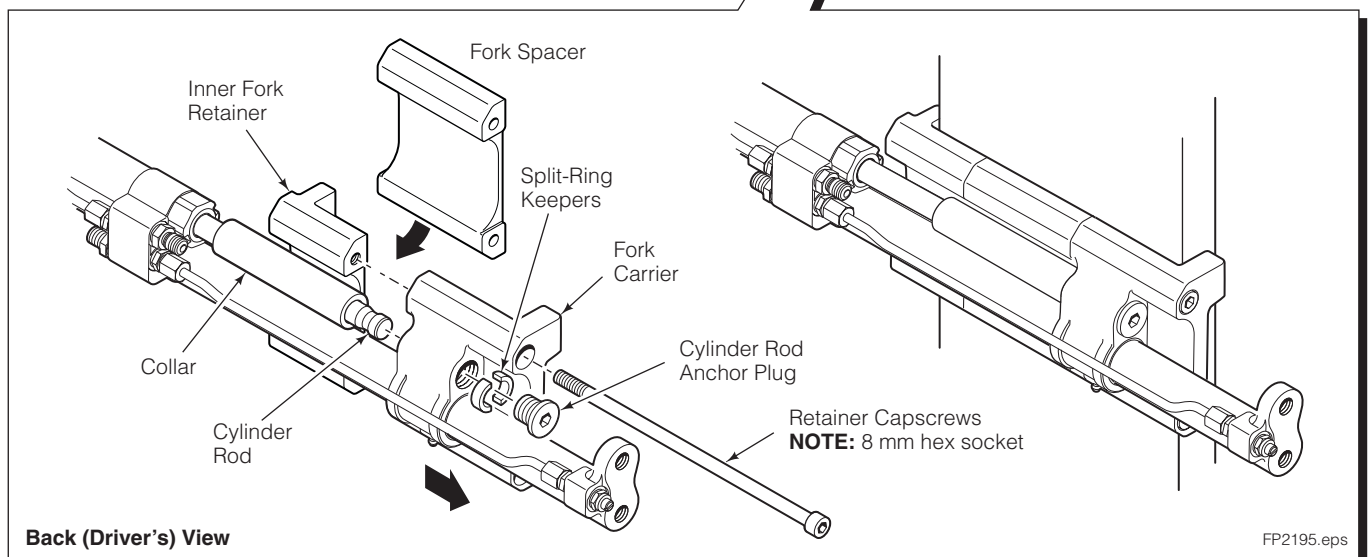
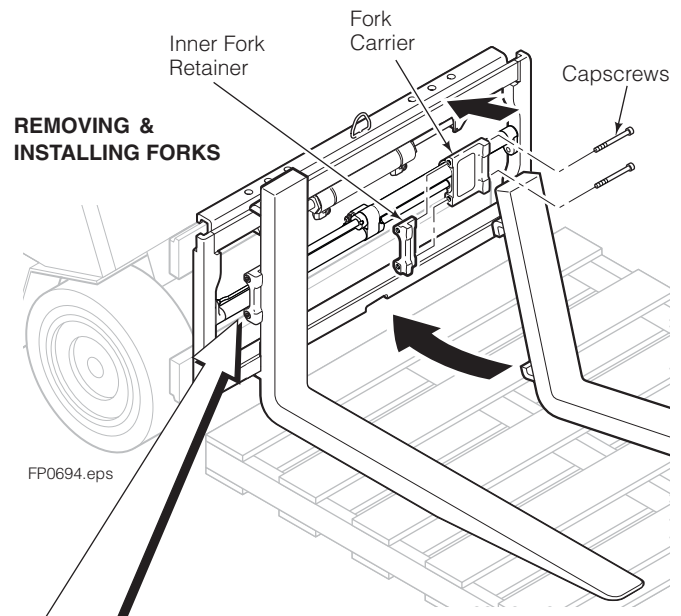

cascade[®]
corporation

For Technical Support . . .

Call: 1-800-227-2233 Fax: 1-888-329-8207

Internet: www.cascorp.com

Write: Cascade Corporation, PO Box 20187, Portland, OR 97294

To Order Parts . . .

Call: 1-888-227-2233 Fax: 1-888-329-0234

Internet: www.cascorp.com

Write: Cascade Corporation, 2501 Sheridan Ave., Springfield, OH 45505

Parts List

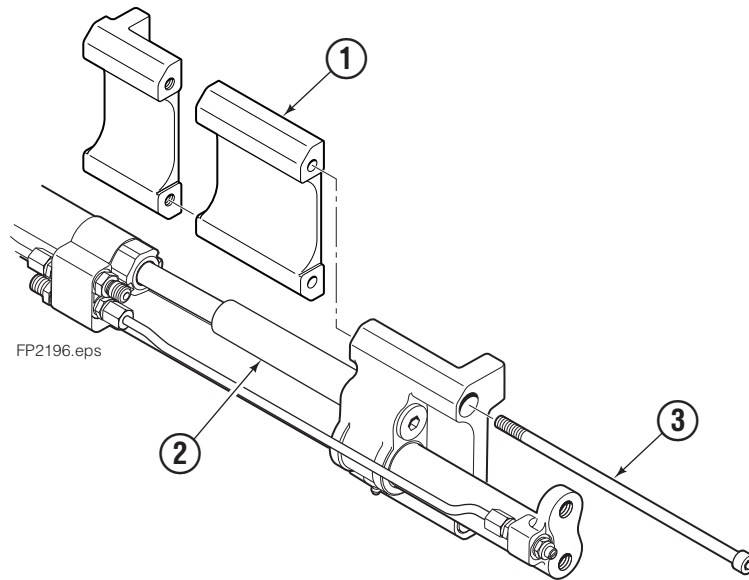

REF	QTY	PART NO.	DESCRIPTION
		6179550	Fork Conversion Kit -10 in. (250 mm)
1	2	6178999	Fork Spacer
2	2	6179548	Collar
3	4	6179216	Capscrew, M12 x 230