



*Shown with optional rubber pads.

Engineered to handle extremely heavy paper rolls and concrete pipe.

APPLICATIONS

The 120H Pivot Arm Clamps are designed for operations that handle large, extremely heavy concrete pipe or paper rolls. This clamp series is available with maximum capacities of 19,000 lbs., 22,000 lbs., 23,100 lbs. and 26,400 lbs. and maximum roll diameters of 105", 90", 85" and 75" respectively. These models have been extensively field-tested and application-rated.

FEATURES

- Heavy duty arm & frame structure modeled after proven roll clamp design.
- Dual rotator drive boxes
- Heavy duty 220D & 400D rotators depending on model
- Thin-frame profile increases truck capacity
- Protected hydraulics
- Easy to service cylinders in standard sizes
- Continuous 360° rotation

MODELS

Fixed Frame/Positioned Short Arm

- Good arm profile over a wide range of roll diameters.



For easy maneuvering of concrete pipe.

120H PIVOT ARM ROLL CLAMP

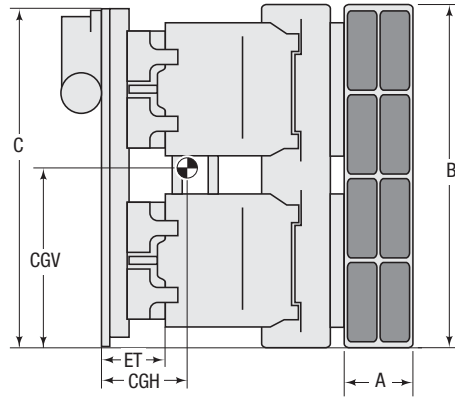
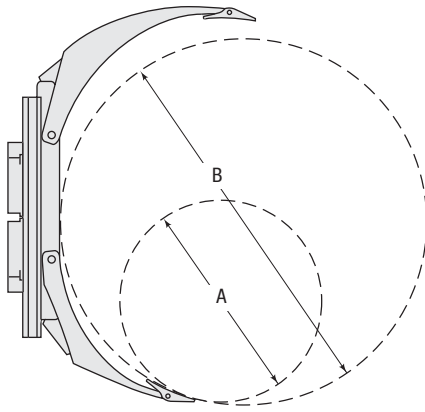

Capacity		Roll Range	Type	Catalog Order No.	Mounting Class	Mounting Angle ①	Weight (Lbs.)	Effective Thickness	Horizontal Center of Gravity	Vertical Center of Gravity	Contact Pad Size	
lbs @ inches	Kg @ mm	A - B						ET	CGH	CGV	A x B	C
26,400@75"	(12,000@1900)	45"-75"	Fixed Short Arm	120H-RCF-01H	①	0°	②	②	②	②	③	50.6"
23,100@85"	(10,500@2106)	55"-85"		120H-RCF-01C	①	0°	②	②	②	②	③	56.1"
22,000@90"	(10,000@2290)	60"-90"		120H-RCF-03H	①	0°	②	②	②	②	③	56.1"
19,000@105"	(8,600@2670)	75"-105"		120H-RCF-03C	①	0°	②	②	②	②	③	56.1"
26,400@75"	(12,000@1900)	33"-75"	Positioned Short Arm	120H-RCP-01H	①	0°	②	②	②	②	③	50.6"
23,100@85"	(10,500@2106)	40"-85"		120H-RCP-01C	①	0°	②	②	②	②	③	56.1"
22,000@90"	(10,000@2290)	45"-90"		120H-RCP-03H	①	0°	②	②	②	②	③	56.1"
19,000@105"	(8,600@2670)	60"-105"		120H-RCP-03C	①	0°	②	②	②	②	③	56.1"

① Various mounting styles are available including ITA, Class V, Pin type, Integral, Modified bolt-on/integral.

② Specifications depend on the style and type of mounting. Consult Cascade for specifications.

③ Pad size will depend on application and product being handled. Contact Cascade.

INSTALLATION KIT

Catalog Order No.

659245

ROTATOR SPECIFICATIONS

	Rotator Speed	Rotator Torque
Standard	2.3 RPM @ 20 GPM	218,000 Inch-Lbs. @ 2,300PSI
Optional	1.8 RPM @ 20 GPM	425,000 Inch-Lbs. @ 2,300PSI

HYDRAULIC FLOW & PRESSURE REQUIREMENTS

Model	Minimum Flow	Recommended Flow	Maximum Flow	Maximum Pressure
Standard	8 GPM	20 GPM	25 GPM*	2,300 PSI/160 bar
Optional	12 GPM	20 GPM	30 GPM	2,300 PSI/160 bar

* Lower hydraulic volume required due to smaller motor size.

HYDRAULIC FLOW CONTROL VALVE

Functions	Input Flow	Output Flow④	Catalog Order No.
1	35 GPM	20 GPM⑤	6026790
1	50 GPM	20 GPM⑤	6037229

④ Input flow recommendations are based on limiting the acceptable pressure drop to the valve to 500 PSI.

⑤ Output flow is preset and is not adjustable.

DAMAGE REDUCTION OPTIONS

- AFC (Adaptive Force Control) for automatic control of clamping pressure that changes as load weight changes (includes Load Cushion™)
- Tilt Control automatically controls the angle of the mast and pad, aligning the pad with the roll and eliminating expensive product damage
- 180° hydraulic stop group
- Load Cushion™—hoist system accumulator that absorbs shocks, reducing the clamp force required to handle the load
- Electrical Pressure relief system allowing driver to change pressure relief settings electronically from the cab

Cascade Corporation • PO Box 20187 • Portland, OR 97294-0187 • USA • 800 CASCADE (227.2233) • Tel 503.669.6257 • Fax 800.693.3768 • Fax 503.669.6367
 Cascade Canada Ltd. • 5570 Timberlea Blvd. • Mississauga, Ontario L4W 4M6 • Canada • 800.380.2272 • Tel 905.629.7777 • Fax 905.629.7785