



## The added capability of inverting and dumping.

### APPLICATIONS

The 30E Rotator gives your driver the ability to quickly dump or invert a load and immediately return the forks to the pick up position in one continuous motion. Cascade rotators are widely used in food processing, automotive manufacturing, and general manufacturing operations where bins or tote boxes are used for both dumping and general handling requirements.

### FEATURES

- **Rugged Construction**—Durable ring gear and drive box combination with deep heat treating of the gear teeth for added durability.
- **Compact Design**—Designed for small truck applications the 30E has reduced lost load and weight for improved net capacity.
- **High Speed 360° Rotation**

### OPTIONS

- **Quick-change Lower Mounting Hooks**—Allow the rotator to be removed or installed in a matter of minutes without tools. (Quick-change hydraulic couplers available separately)
- **Extended Width Fork Bars**
- **Special Forks**

*For load  
inverting and  
dumping  
versatility.*



# 30E ROTATOR

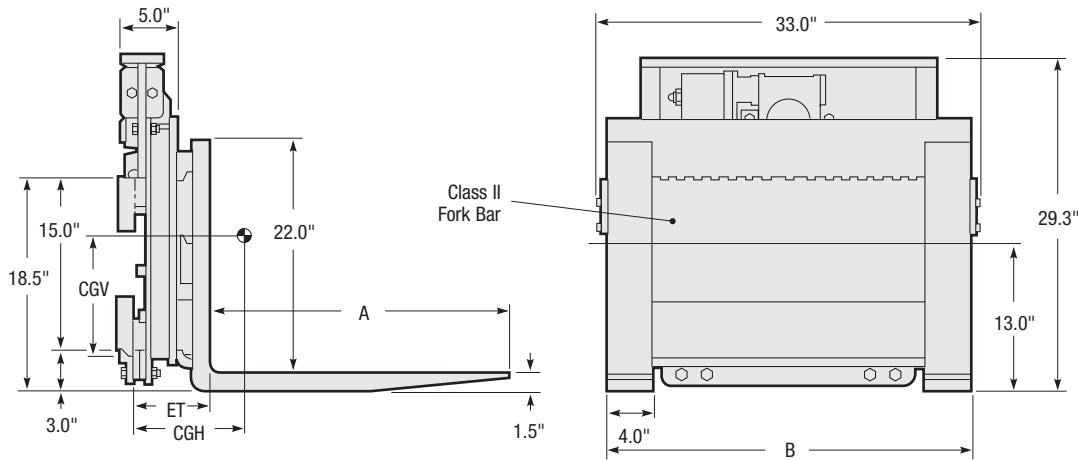

## 360° Rotation

Capacity Lbs. @ 24" Load Center	Fork Length A	Fork Bar Width (Fork Spread) B	Catalog Order No.	Mounting Class	Mounting Angle	Minimum Truck Carriage Width	Weight (Lbs.)	Effective Thickness ET	Horizontal Center of Gravity HCG	Vertical Center of Gravity VCG
3,200	w/o Forks	32"	30E-RRB-10A	II	0°	24"	415	5.0"	2.2"	12.5"
3,000	30"	32"	30E-RRB-11A	II	0°	24"	560	6.5"	4.8"	10.5"
3,000	36"	32"	30E-RRB-12A	II	0°	24"	570	6.5"	5.9"	10.1"
3,000	42"	32"	30E-RRB-13A	II	0°	24"	590	6.5"	7.0"	9.7"
3,000	48"	32"	30E-RRB-14A	II	0°	24"	610	6.5"	8.1"	9.3"

- ① Rotator rating limited by fork capacity.
- ▶ Speed: 7.5 RPM @ 10 GPM. Torque: 32,000 Inch-Lbs. @ 2,000 PSI.
- ▶ Rotators are available with or without forks.
- ▶ Rotators sold without forks are shipped with middle fork hooks.
- ▶ All rotators feature continuous 360° rotation.

## INSTALLATION KIT

Catalog Order No.  
681060

## HYDRAULIC FLOW & PRESSURE

Model	Minimum	Recommended	Maximum	Maximum Pressure
30E	5 GPM	7 GPM	10 GPM	2,300 PSI

## HYDRAULIC FUNCTIONS

Hydraulic Functions	Truck Auxiliary Valves Required
1	1

## MOUNTING CLASS INFORMATION

Mounting Class	Truck Capacity
II	2,000-5,500 lbs.

## ADDITIONAL OPTIONS



### 180° Rotation Stop Group (Factory Installed)

Provides a permanent rotation stop point at the vertical handling position.

Catalog Order No.  
SG10

## ADDITIONAL OPTIONS

### Load Hold Down

For use in handling wood or steel bins—light loads (bins with no pockets on bottom).

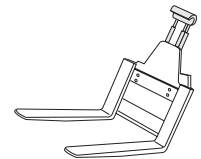

### Visibility Hole

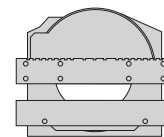

### Side Stabilizers—Fixed Fork

For use in handling wood or steel bins—light loads.

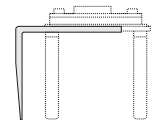

### Side Stabilizers—Folding Fork

For use in handling wood or steel bins—light loads.

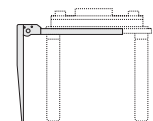

### Fork Side Restraints

