



Technical Bulletin

10H through 33H Roll Clamp Arm Tip and Wear Plate Service Repair Kits

This sheet describes arm tip removal and wear plate installation procedures for Roll Clamp Service Repair Kits 6814054, 6814103, 6810076, 6833087 and 6848224. Metal sawing and welding is required.



WARNING: Cascade Corporation recommends that a qualified welder experienced in this type of repair be used for best quality.

Clamp Model	Service Kit	Kit Contents
10H, 18H, 20H	6848224	Arm Tips, Wear Plates
13H	6833087	Arm Tips, Wear Plates
22H, 24H	6814054	Arm Tips, Wear Plates
25H, 30H, 33H	6814103	Arm Tips, Wear Plates
13H thru 33H	6810076	Wear Plates (8)

Removing Contact Pads

- 1 Rotate the clamp to the vertical roll handling position. Lower the clamp until the contact pads are approximately 1.0 in. (25.0 mm) from the ground.
- 2 Remove the retaining rings from the clevis pins. While removing the clevis pins, unhook the spring anchors. Springs will remain fixed to the arms.
- 3 Remove the drive pins from the contact pad pivot points and remove pivot pins.
- 4 Remove the contact pad and pad suspension springs. Pad links can be removed from the arm by rotating 90 degrees and pulling out.

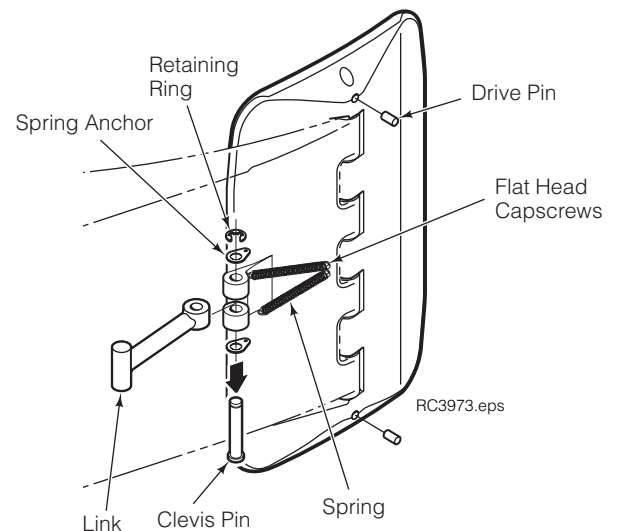

NOTE: This information should not be interpreted as the basis for warranty claims unless so designated.

cascade[®]
corporation

For Technical Support . . .

Call: 1-800-CASCADE (227-2233)

OR

Write: Cascade Corporation, PO Box 20187, Portland, OR 97294-0187

To Order Parts . . .

Call: 1-888-CASCADE (227-2233)

OR

Write: Cascade Corporation, 2501 Sheridan Ave., Springfield, OH 45505

Wear Tile Repair

- 1 Position the wear tiles on the back of the short arm using the dimensions shown. Tack, then weld the wear tiles using the weld procedures described on page 5, Step 8.

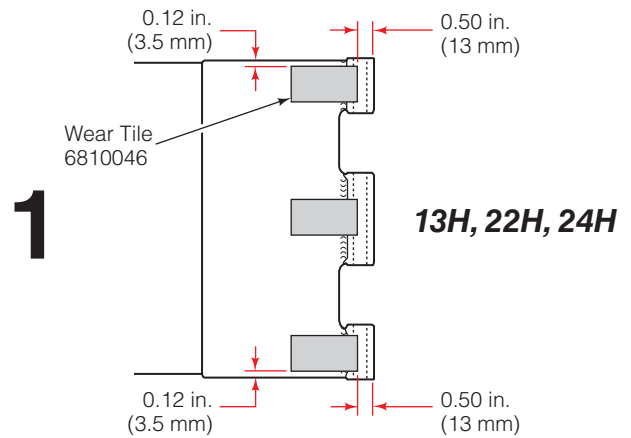
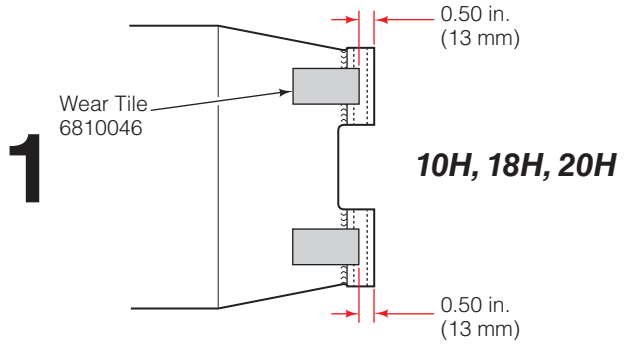
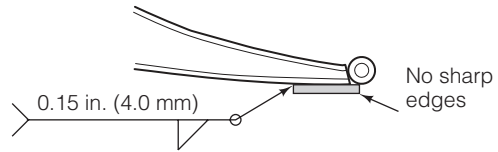

- 2 Remove slag after each weld and inspect for defects.

NOTE: Arc craters, undercut, overlap and porosity are not permitted. Repair any defect as required.

- 3 Grind all welds to smooth transitions between parts.

- 4 Install contact pads by reversing Steps 1 through 4 of Removing Contact Pads.

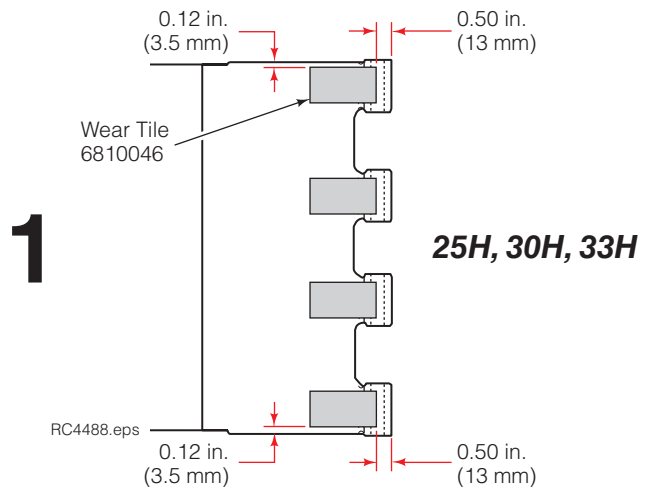

Arm Tip Service

- 1 Place the tool against the tip with raised ribs on the inner arm surface and the spacers in between each tip. Tack weld two blocks (user equipped) to the inside of the arm as a marker at the edge of the tool. Remove the tool.

IMPORTANT: Avoid damage to machined features and threaded holes.

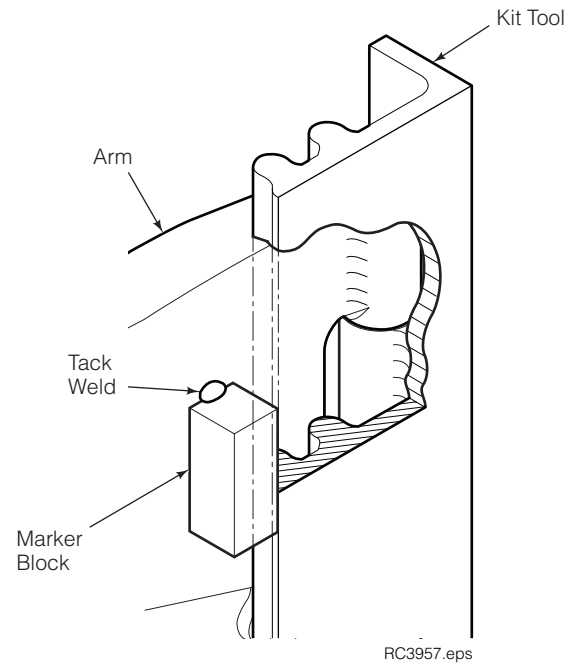
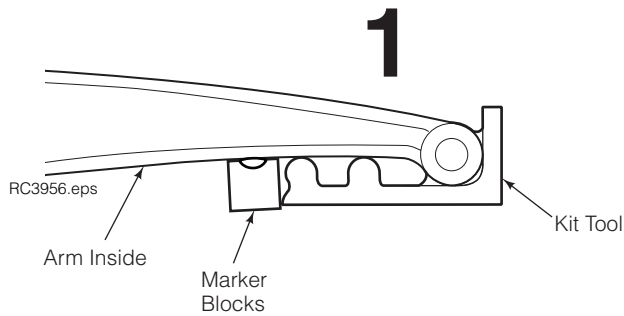

- 2 Scribe a cut line 0.20 ± 0.03 in. (5 ± 0.7 mm) back from the inner surface of the existing tip holes on both sides of the arm tips.
- 3 Remove defective tip area entirely at the cut line by grinding, sawing, torch or arc gouging. Remove any paint contamination from around the repair area. If arc gouging is used, make sure all carbon particles are completely removed.

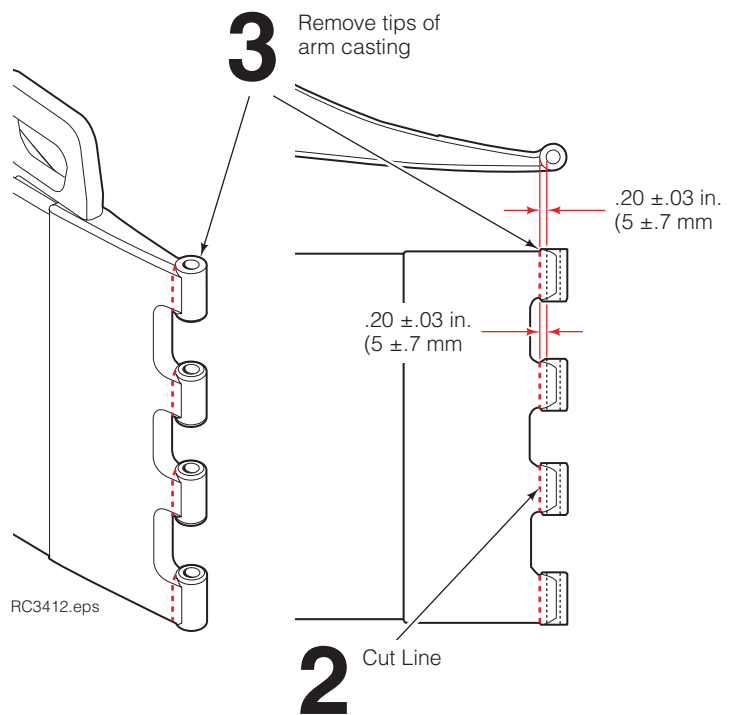

- 4 Clamp the kit tool against the marker blocks.

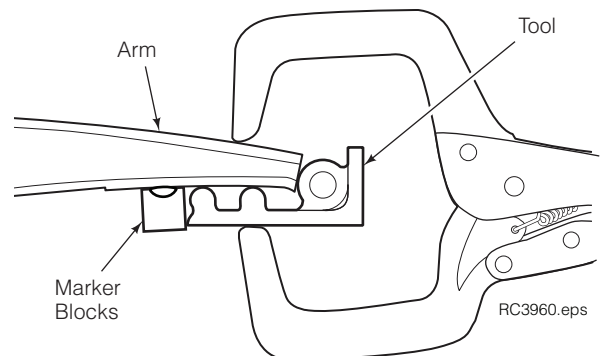

- 5 Position the new tubes on the arm tips using the kit tool. Place existing pivot pin through all tubes and kit tool for alignment. All repairs should be done in the flat position.

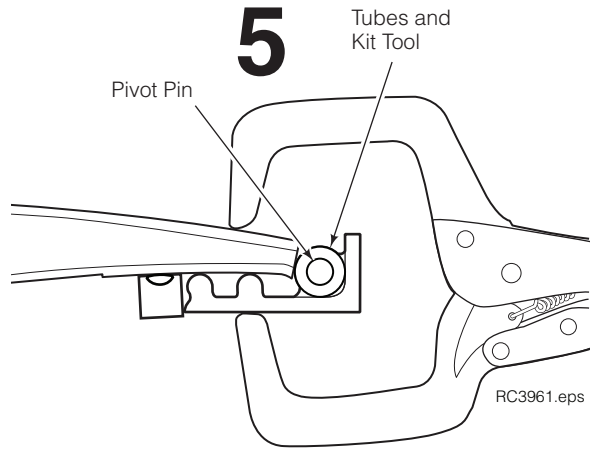

- 6 Preheat arm tip base metal to 70°F (21°C) minimum. Tack weld new tubes to the tips. Use the recommended weld procedures listed in step 8. Remove kit tool.

- 7 Install the contact pad and pivot pin on the arm. Check the tube alignment, realign as required. Remove the contact pad and pin.

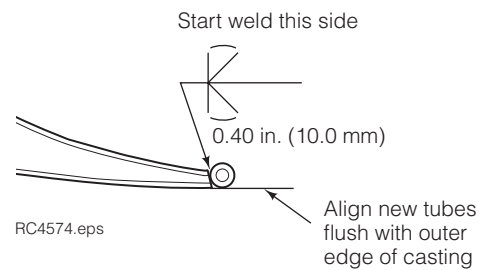

- 8 Finish-weld the tubes to the arm tips and wear tiles using the following weld procedures:

- Protect inside of tubes from weld spatter.
- Preheat arm tip base metal to 150°F (66°C). Monitor and maintain arm tip heat at locations shown using suitable temperature-indicating devices.
- **Weld Sequence** – Start weld on side indicated. Terminate each weld at center of tube.
- **WELD METHOD A** – FCAW (Flux-Cored Arc Weld). Attach ground wire to arm. Weld using AWS E70T-1 1/16 in. (1.6 mm) or 5/64 in. (2 mm) diameter wire with 100% CO₂ shielding gas at 35-50 CFH. Set welding amp per manufacturers recommendations. Apply weld holding a close arc. Do not oscillate or use a wash bead pattern.
- **WELD METHOD B** – SMAW (Stick Welding). Attach ground wire to arm. Weld using E-7015 low hydrogen 1/8 in. (3.2 mm) or 5/32 in. (4.0 mm) diameter electrodes. Set welding amps per manufacturer's recommendations. **Do not use electrode exposed to moisture without first re-drying them at 200°F (75°C) for 2 hours.** Apply weld holding a close arc. Do not oscillate or use a wash bead pattern.
- Cool arm tip base metal at normal air cool.
- Remove marker blocks. Smooth out tack weld spots.

10H

8

Temperature Measurement Areas

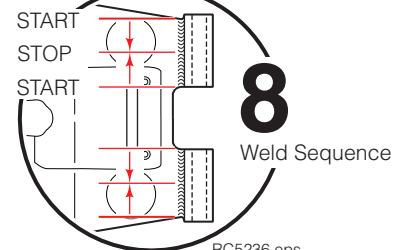
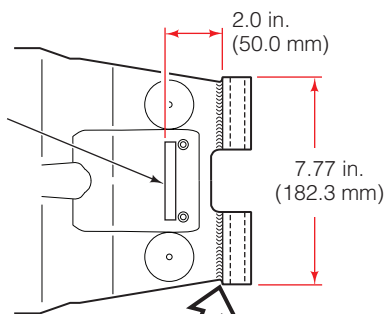

13H

8

Temperature Measurement Areas

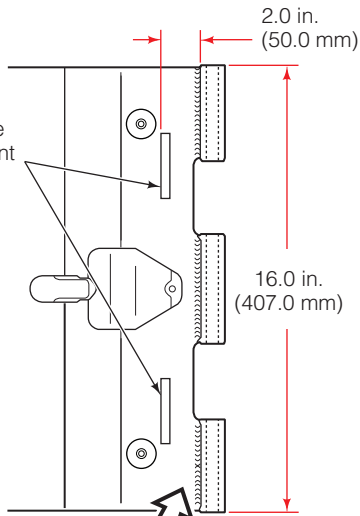

8

Weld Sequence

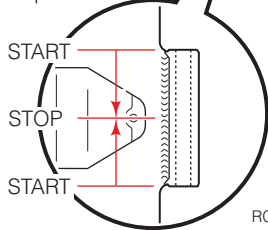

RC5226.eps

18H, 20H

8

Temperature Measurement Areas

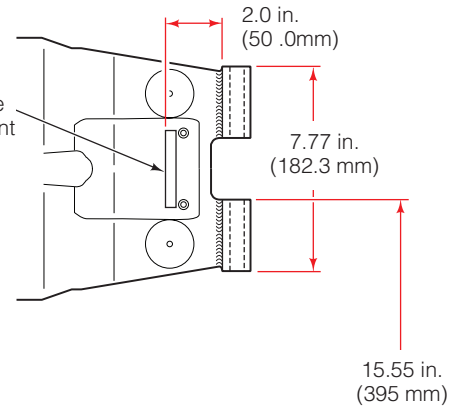

8

Weld Sequence

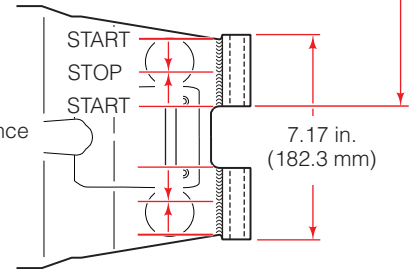

22H, 24H

8

Temperature Measurement Areas

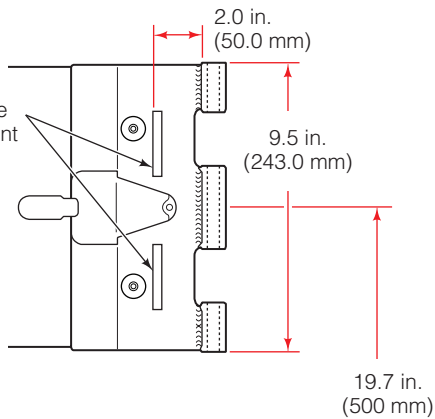

8

Weld Sequence

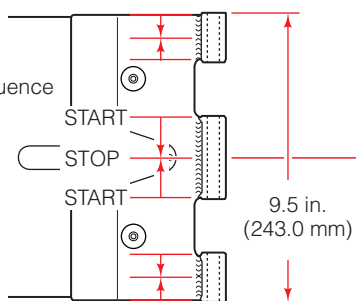

RC3967.eps

25H, 30H, 33H

8

Temperature Measurement Areas

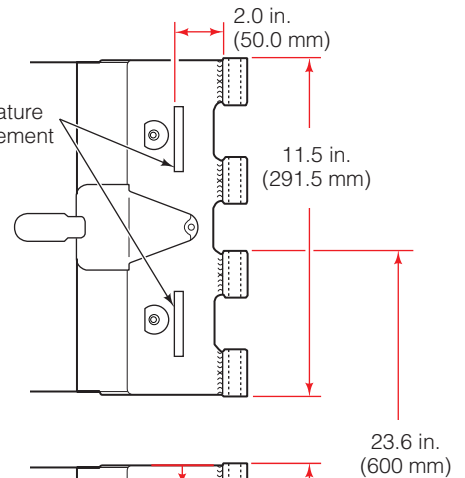

8

Weld Sequence

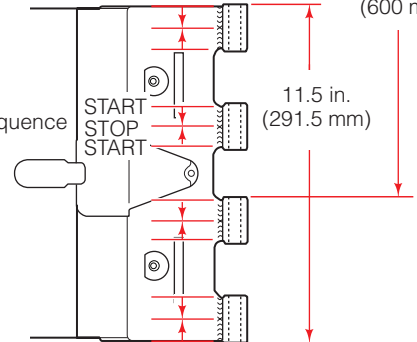

RC3968.eps

Do you have questions you need answered right now? Call your nearest Cascade Service Department. Visit us online at www.cascorp.com

AMERICAS

**Cascade Corporation
U.S. Headquarters**
2201 NE 201st
Fairview, OR 97024-9718
Tel: 800-CASCADE (227-2233)
Fax: 888-329-8207

Cascade Canada Inc.
5570 Timberlea Blvd.
Mississauga, Ontario
Canada L4W-4M6
Tel: 905-629-7777
Fax: 905-629-7785

Cascade do Brasil
Praça Salvador Rosa,
131/141-Jordanópolis,
São Bernardo do Campo - SP
CEP 09891-430
Tel: 55-13-2105-8800
Fax: 55-13-2105-8899

EUROPE-AFRICA

**Cascade Italia S.R.L.
European Headquarters**
Via Dell'Artigianato 1
37030 Vago di Lavagno (VR)
Italy
Tel: 39-045-8989111
Fax: 39-045-8989160

Cascade (Africa) Pty. Ltd.
PO Box 625, Isando 1600
60A Steel Road
Sparton, Kempton Park
South Africa
Tel: 27-11-975-9240
Fax: 27-11-394-1147

ASIA-PACIFIC

Cascade Japan Ltd.
2-23, 2-Chome,
Kukuchi Nishimachi
Amagasaki, Hyogo
Japan, 661-0978
Tel: 81-6-6420-9771
Fax: 81-6-6420-9777

Cascade Korea
121B 9L Namdong Ind.
Complex, 691-8 Gojan-Dong
Namdong-Ku
Inchon, Korea
Tel: +82-32-821-2051
Fax: +82-32-821-2055

Cascade-Xiamen
No. 668 Yangguang Rd.
Xinyang Industrial Zone
Haicang, Xiamen City
Fujian Province
P.R. China 361026
Tel: 86-592-651-2500
Fax: 86-592-651-2571

**Cascade India Material
Handling Private Limited**
No 34, Global Trade Centre
1/1 Rambaugh Colony
Lal Bahadur Shastri Road,
Navi Peth, Pune 411 030
(Maharashtra) India
Phone: +91 020 2432 5490
Fax: +91 020 2433 0881

Cascade Australia Pty. Ltd.
1445 Ipswich Road
Rocklea, QLD 4107
Australia
Tel: 1-800-227-223
Fax: +61 7 3373-7333

Cascade New Zealand
15 Ra Ora Drive
East Tamaki, Auckland
New Zealand
Tel: +64-9-273-9136
Fax: +64-9-273-9137

**Sunstream Industries
Pte. Ltd.**
18 Tuas South Street 5
Singapore 637796
Tel: +65-6795-7555
Fax: +65-6863-1368

