

U *SER MANUAL*

K-Series

Fork Positioner Kit

Manual Number 6054167-R5

cascade®
corporation

Cascade is a Registered Trademark of Cascade Corporation

	Page
INTRODUCTION	
Special Definitions	1
OPERATION	
Safety Rules	2
Industrial Lift Trucks	2
Handling Loads	3
Fork Positioner Operation	3
Daily Inspection	4
Safe Operation and Maintenance	5
OSHA Regulations	5
INSTALLATION	
Truck Requirements	6
Recommended Hydraulic Supply	7
Installation Procedure	8
PERIODIC MAINTENANCE	
100-Hour Maintenance	14
300-Hour Maintenance	14
1000-Hour Maintenance	14
2000-Hour Maintenance	15
PARTS	
Product Identification	16
Recommended Spare Parts	16
Publications	16

INTRODUCTION

This User Manual is for the Cascade K-Series Fork Positioner. Contents include an Operator's Guide, Installation Instructions, Periodic Maintenance and Recommended Spare Parts.

NOTE: All specifications are shown in U.S. and (Metric) units where applicable. All fasteners have a torque value range of $\pm 10\%$ of stated value.

IMPORTANT: K-Series Fork Positioner is metric. Supply fittings adapted as required for application.

Special Definitions

The statements shown appear throughout this Manual where special emphasis is required. Read all WARNINGS and CAUTIONS before proceeding with any work. Statements labeled IMPORTANT and NOTE are provided as additional information of special significance or to make the job easier.



WARNING – A statement preceded by WARNING is information that should be acted upon to prevent **bodily injury**. A WARNING is always inside a ruled box.



WARNING: Rated capacity of the truck/attachment combination is a responsibility of the original truck manufacturer and may be less than shown on the attachment nameplate. Consult the truck nameplate.

WARNING: Do not operate this attachment unless you are a trained and authorized lift truck driver.

WARNING: Usable fork length must not exceed 60 in. (1500 mm).

CAUTION – A statement preceded by CAUTION is information that should be acted upon to prevent machine damage.

IMPORTANT – A statement preceded by IMPORTANT is information that possesses special significance.

NOTE – A statement preceded by NOTE is information that is handy to know and may make the job easier.

OPERATION

This section contains operating instructions for the Cascade K-Series Fork Positioner Kit. It will help you avoid common errors which often cause damage to the equipment or product being handled.

This information is intended to simplify operator understanding about effective and safe fork positioner use and operation. Read this information thoroughly before operating the attachment. Be sure you know and understand all operating procedures and safety precautions. If you have any questions, or don't understand a procedure, ask your supervisor.

Emphasize Safety! Most accidents are caused by operator carelessness or misjudgment. You must watch for poorly maintained equipment and hazardous situations and correct them.

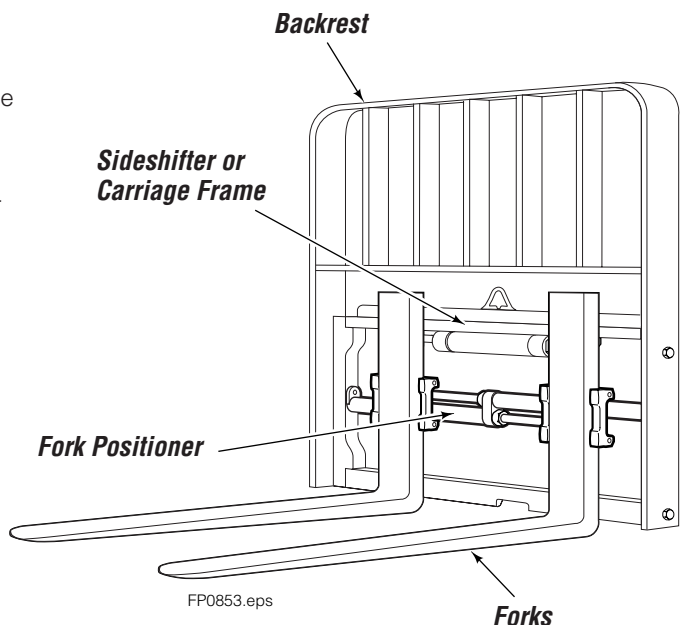

0

PERATION

Safety Rules – Industrial Lift Trucks

No riders



No reaching through mast



No standing under load



GA0047.eps



Motor off, park, lower load

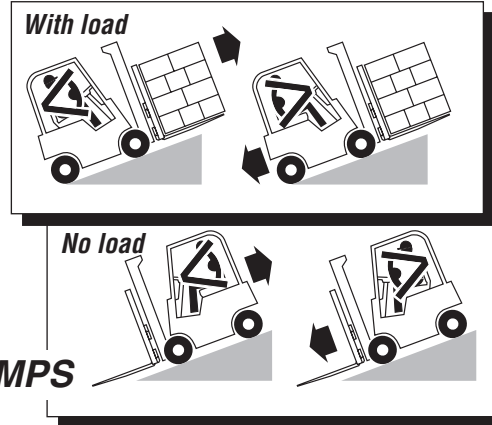
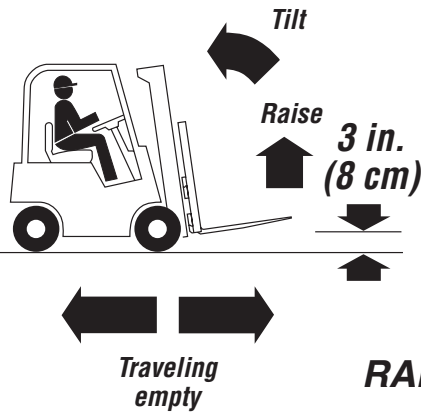

GA0048.eps

TRAFFIC



Observe



Wet floors



Workers



Stops



Bumps



Dips



Slow for two-way traffic

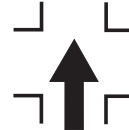

Sound horn, slow at intersection



Sound horn, slow at corner

OPERATION

Safety Rules – Handling Loads

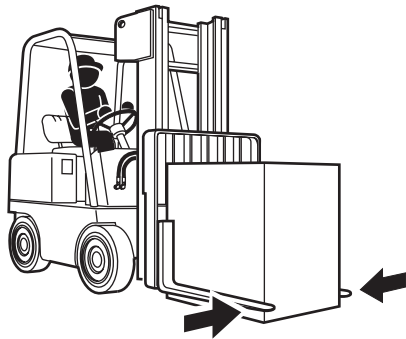

CAUTION: Do not put side loads on forks.

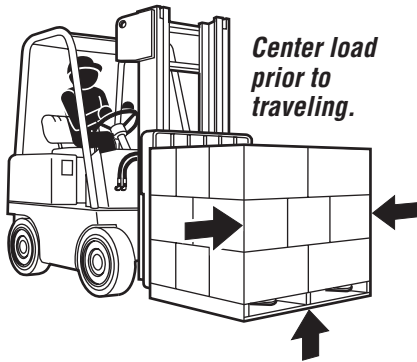

Center load prior to traveling.

Raise load prior to sideshifting.

Limit sideshifting with raised load.

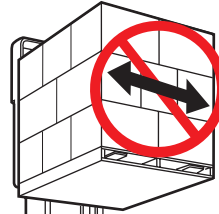

Limit truck movement with raised load.

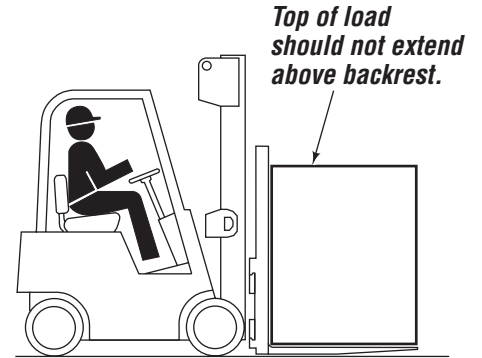

Top of load should not extend above backrest.

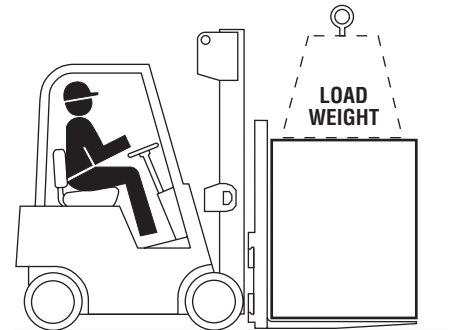

FP0174.eps

Load weight must not exceed combined truck/attachment capacity (see truck nameplate).

Total fork capacity (LH + RH fork) must be greater than load weight. Check capacity stamp on forks.

Fork Positioner Operation

AUXILIARY VALVE FUNCTIONS

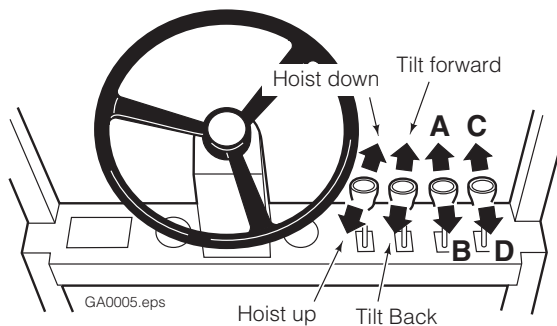

GA0005.eps



WARNING: Truck control handle and attachment function activation shown here conforms to ASME/ANSI B56.1 recommended practices. Failure to follow these practices may lead to serious bodily injury or property damage. End user, dealer and OEMs should review any deviation from the practices for safe operation.

SIDESHIFTING/ FORK POSITIONING

- A** Sideshift Left
- B** Sideshift Right
- C** Open Forks
- D** Close forks

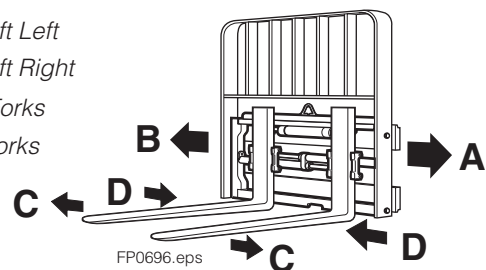

FP0696.eps

OPERATION

Daily Inspection

Check items shown each day. Report problems to your supervisor. See Service Manual for troubleshooting and repair procedures.

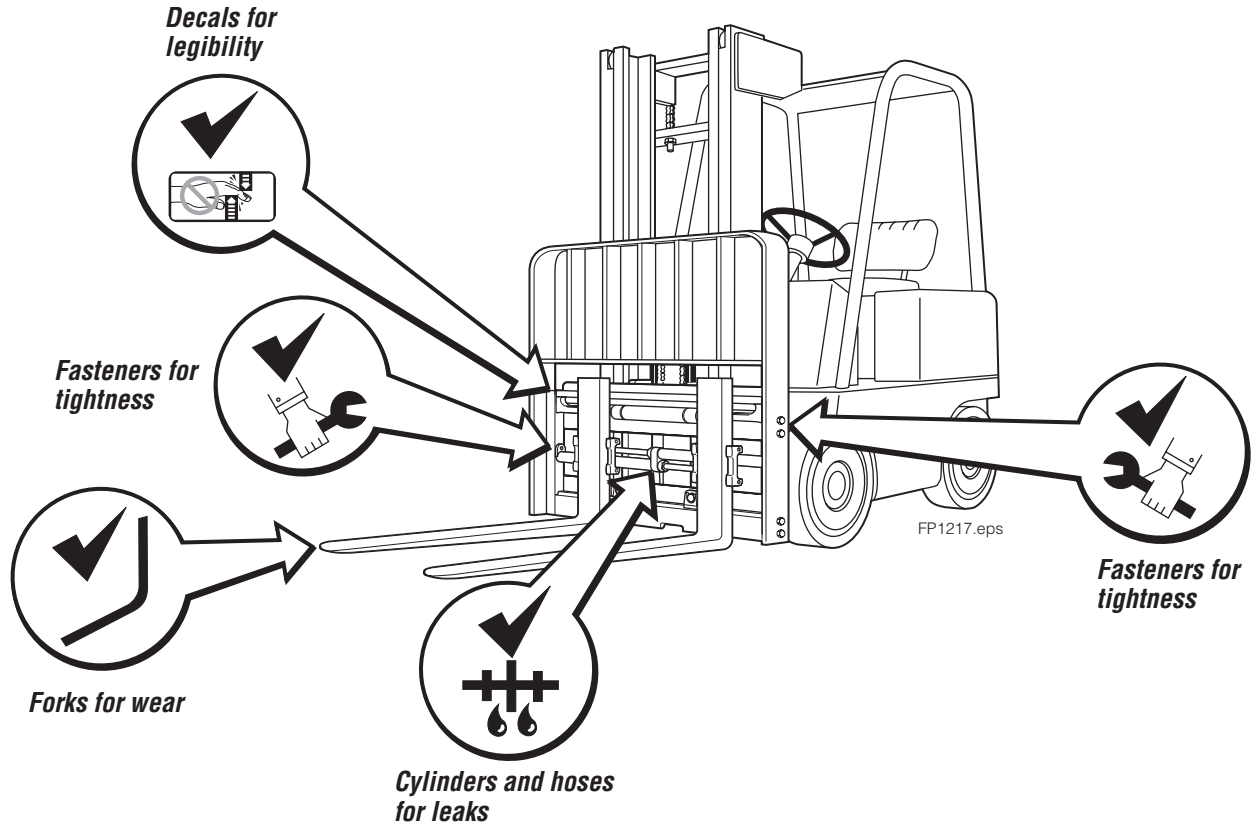



SAFE OPERATION AND MAINTENANCE

OSHA Regulations – Industrial Trucks and Attachments (Specific Regulations from OSHA 1910.178)



WARNING: The safe operation and maintenance of industrial trucks is regulated by Occupational Safety and Health (OSHA) regulations 1910.178 and American National Standards Institute (ANSI) Safety Standard for Powered Industrial Trucks, ANSI B56.1. When operating and maintaining industrial trucks equipped with attachments you should pay particular attention to the following sections of these regulations. You should be familiar with **all** sections of these regulations. **Ask your employer for the complete regulations.**

(a) General Requirement

- (4) Modifications and additions which affect capacity and safe operation shall not be performed by the customer or user without manufacturers prior written approval. Capacity, operation and maintenance instruction plates, tags or decals shall be changed accordingly.
- (5) If the truck is equipped with front-end attachments other than factory installed attachments, the user shall request that the truck be marked to identify the attachments and show the appropriate weight of the truck and attachment combination at maximum elevation with load laterally centered.
- (6) The user shall see that all nameplates and markings are in place and maintained in a legible condition.

(e) Safety Guards

- (2) If the type of load presents a hazard, the user shall equip fork trucks with a vertical load backrest extension in accordance with (a)(2) following.

(a)(2) All new powered industrial trucks acquired and used by an employer after February 15, 1972 shall meet the design and construction requirements for powered industrial trucks established in the "American National Standard for Powered Industrial Trucks, Part II, ANSI B56.1", except for vehicles intended primarily for earth moving or over-the-road hauling.

(l) Operator Training

Only trained and authorized operators shall be permitted to operate a powered industrial truck. Methods shall be devised to train operators in the safe operation of powered industrial trucks.

(m) Truck Operations

- (1) Trucks shall not be driven up to anyone standing in front of a bench or other fixed object.
- (2) No person shall be allowed to stand or pass under the elevated portion of any truck, whether loaded or empty.
- (3) Unauthorized personnel shall not be permitted to ride on powered industrial trucks. A safe place to ride shall be provided where riding of trucks is authorized.
- (4) The employer shall prohibit arms or legs from being placed between the uprights of the mast or outside the running lines of the truck.
- (5i) When a powered industrial truck is left unattended, load engaging means shall be fully lowered, controls shall be neutralized, power shall be shut off and brakes set. Wheels shall be blocked if the truck is parked on an incline.
- (5ii) A powered industrial truck is unattended when the operator is 25 feet or more away from the vehicle which remains in his view, or whenever the operator leaves the vehicle and it is not in his view.
- (5iii) When the operator of an industrial truck is dismounted and within 25 feet of the truck still in his view, the load engaging means shall be fully lowered, controls neutralized and the brakes set to prevent movement.

- (6) A safe distance shall be maintained from the edge of ramps or platforms while on any elevated dock or platform or freight car. Trucks shall not be used for opening or closing freight doors.
- (10) A load backrest extension shall be used whenever necessary to minimize the possibility of the load or part of it from falling rearward.

(n) Traveling

- (4) The driver shall be required to slow down and sound the horn at cross isles and other locations where vision is obstructed. If the load being carried obstructs forward view, the driver shall be required to travel with the load trailing.
- (7i) When ascending or descending grades in excess of 10 percent, loaded trucks shall be driven with the load upgrade.
- (7iii) On all grades the load and load engaging means shall be tilted back if applicable, and raised only as far as necessary to clear the road surface.

(o) Loading

- (1) Only stable or safely arranged loads shall be handled. Caution shall be exercised when handling off-center loads which cannot be centered.
- (2) Only loads within the rated capacity of the truck shall be handled.
- (3) The long or high (including multiple-tiered) loads which may affect capacity shall be adjusted.
- (4) Trucks equipped with attachments shall be operated as partially loaded trucks when not handling a load.
- (5) A load engaging means shall be placed under the load as far as possible; the mast shall be carefully tilted backward to stabilize the load.
- (6) Extreme care shall be used when tilting the load forward or backward, particularly when high tiering. Tilting forward with load engaging means elevated shall be prohibited except to pick up a load. An elevated load shall not be tilted forward except when the load is in a deposit position over a rack or stack. When stacking or tiering, only enough backward tilt to stabilize the load shall be used.

(p) Operation of the Truck

- (1) If at any time a powered industrial truck is found to be in need of repair, defective, or in any way unsafe, the truck shall be taken out of service until it has been restored to safe operating condition.

(q) Maintenance of Industrial Trucks

- (1) Any power-operated industrial truck not in safe operating condition shall be removed from service. All repairs shall be made by authorized personnel.
- (5) All parts of any such industrial truck requiring replacement shall be replaced only by parts equivalent as to safety with those used in the original design.
- (6) Industrial trucks shall not be altered so that the relative positions of the various parts are different from what they were when originally received from the manufacturer, nor shall they be altered either by the addition of extra parts not provided by the manufacturer or by the elimination of any parts. Additional counter-weighting of fork trucks shall not be done unless approved by the truck manufacturer.
- (7) Industrial trucks shall be examined before being placed in service and shall not be placed in service if the examination shows any condition adversely affecting the safety of the vehicle. Such examinations shall be made at least daily. When industrial trucks are used on a round-the-clock basis, they shall be examined after each shift. Defects when found shall be immediately reported and corrected.

Truck Requirements

Truck Relief Setting

2200 psi (152 bar) Recommended

3500 psi (241 bar) Maximum

Truck Flow Volume ^①

	Min. ^②	Recommended	Max. ^③
55K, 65K	1 GPM (4 L/min.)	2 GPM (7.5 L/min.)	3 GPM (12 L/min.)
100K, 120K, 150K, 165K	1 GPM (4 L/min.)	4 GPM (16L/min.)	5 GPM (20 L/min.)

- ① Cascade K-Series Fork Positioner/Sideshifters are compatible with SAE 10W petroleum base hydraulic fluid meeting Mil. Spec. MIL-O-5606 or MIL-O-2104B. Use of synthetic or aqueous base hydraulic fluid is not recommended. If fire resistant hydraulic fluid is required, special seals must be used. Contact Cascade.
- ② Flow less than recommended will result in slow fork positioning speed.
- ③ Flow greater than maximum can result in excessive heating, reduced system performance and short hydraulic system life.

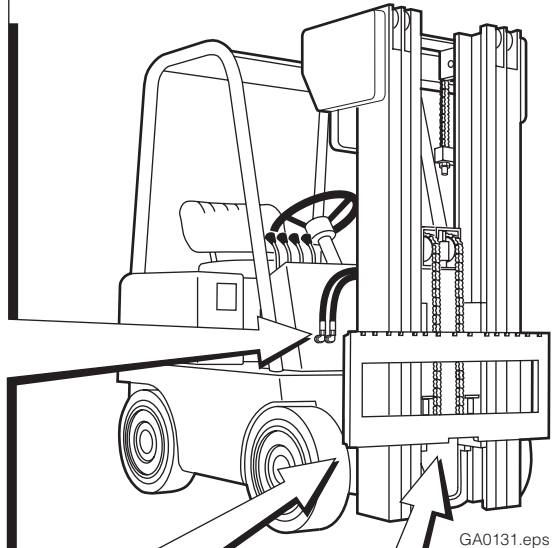

GA0131.eps



GA0028.eps

Carriage Mount Dimension (A) ITA (ISO)

	Minimum	Maximum
Class II	14.94 in. (380.0 mm)	15.00 in. (381.0 mm)
Class III	18.68 in. (474.5 mm)	18.74 in. (476.0 mm)
Class IV	23.44 in. (595.5 mm)	23.50 in. (597.0 mm)

Carriage – Clean and inspect carriage bars. Make sure that bars are parallel and that ends are flush. Grind smooth any protruding welds that may affect Sideshifter lower bearings. Repair any damaged notches.

Auxiliary Valve Functions

Check for compliance with ANSI (ISO) standards:

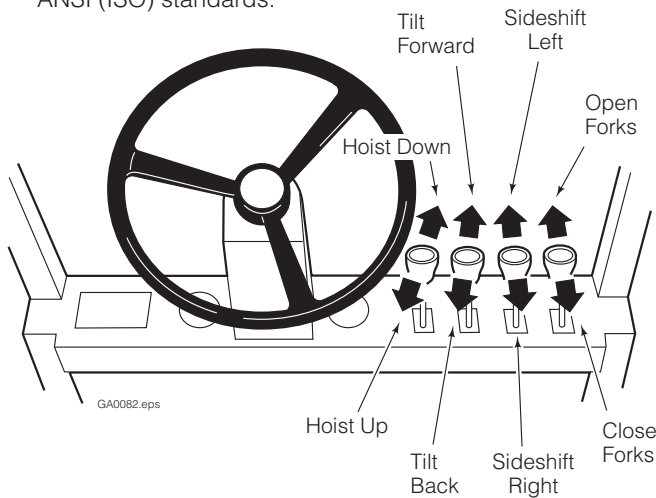

GA0082.eps

Recommended Hydraulic Supply

Fork Positioning function: No. 3 hose/No. 4 fittings with 5/32 in. (4 mm) minimum ID.

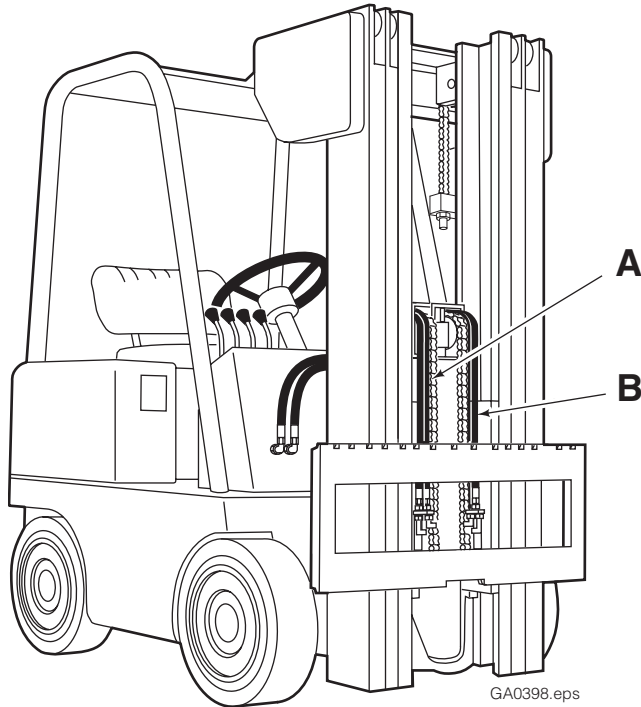

Fork Positioning

A Mast Single Internal Reeving

Fork Positioning & Sideshifting

A & B Mast Double Internal Reeving

Installation Procedure

1 Check Mounting Location

- A** Make sure fork positioner assembly has adequate clearance within sideshift or carriage frame for maximum fork carrier movement.
- B** If installing in a Cascade sideshifter, make sure predrilled mounting holes are correct to accept fork positioner assembly.
- C** If required, grind corner and/or mounting face of end bar for clearance.
- D** If fitting to an OEM sideshifter or mast carriage, contact Cascade for correct mounting hole location.

2 Determine Shimming Required

- A** Install fork positioner assembly and tighten capscrews on one side.
 - B** Measure gap at opposite side and determine total number of shims required.
 - C** Install shims with a maximum 4 per side so total gap after shimming does not exceed .020 in. (0.5 mm).
- NOTE:** Maximum difference in number of shims per side is 2.

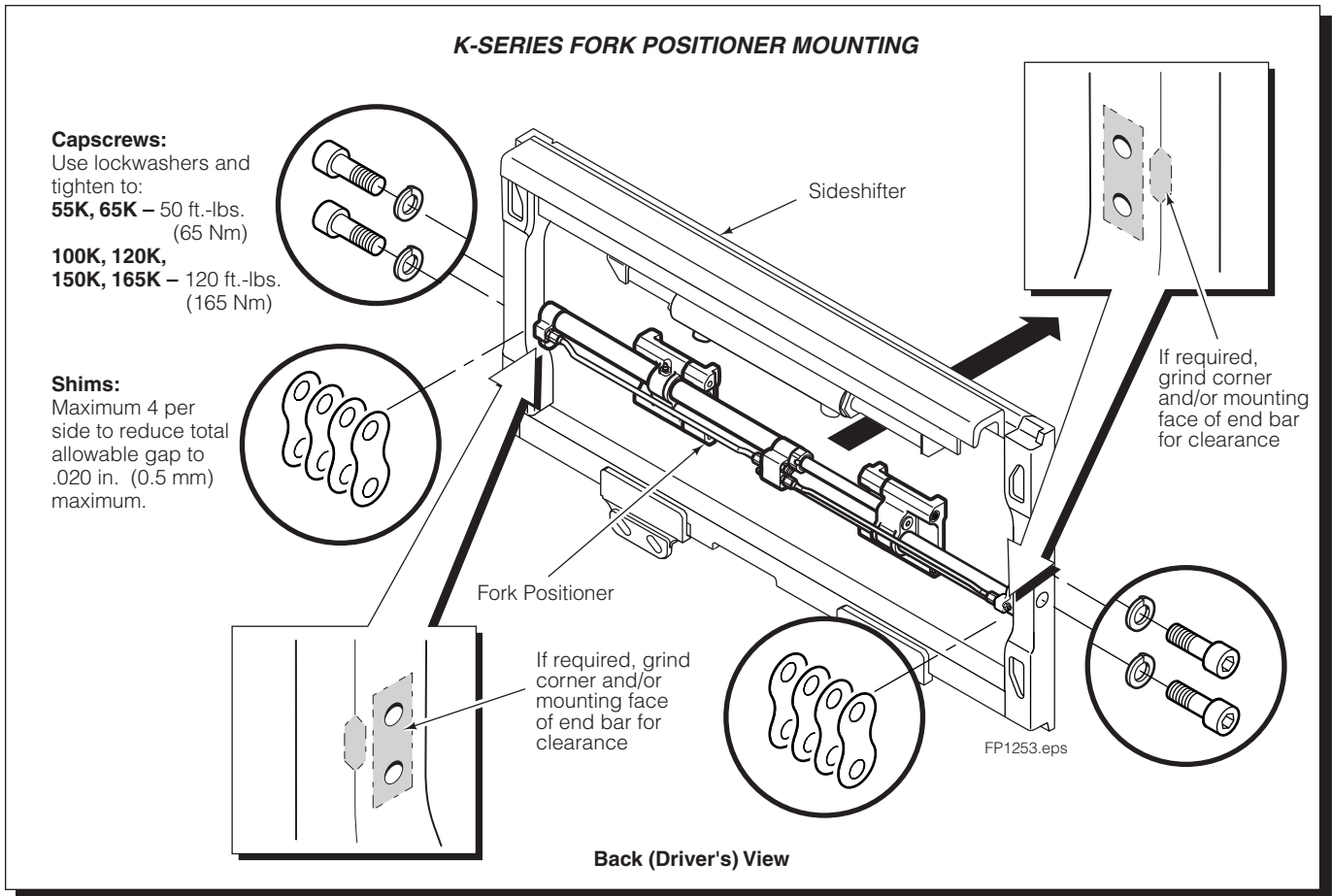

3 Tighten Capscrews

- A** Tighten capscrews (with lockwashers) to :
55K, 65K – 50 ft.-lbs. (65 Nm)
100K, 120K, 150K, 165K – 120 ft.-lbs. (165 Nm)
- B** Install backrest (if applicable).

4 Flush supply hoses

- A** Connect supply hoses to supply terminals and connect together using a union fitting as shown.
- B** Operate auxiliary valve for 30 sec.
- C** Remove union fitting

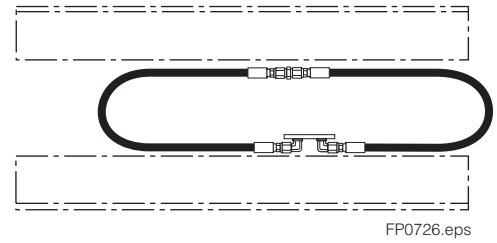

5 Install hoses

CAUTION: Allow for 4 inches movement in each direction for sideshifting ('rolling' hose arrangement recommended).

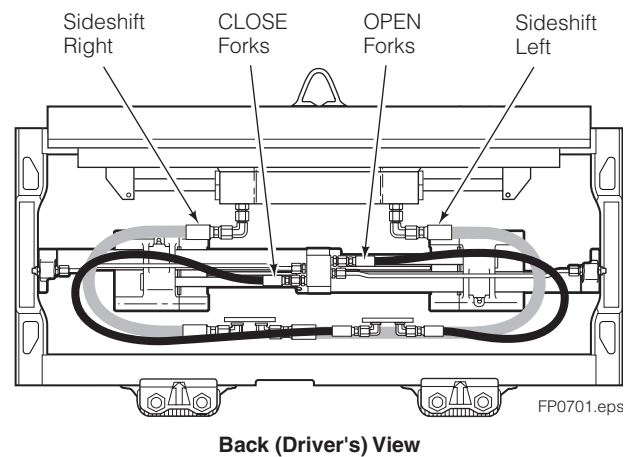

6 Remove fork locking pins



WARNING: Remove locking pins from forks. Make sure that forks slide freely on carriage bars.

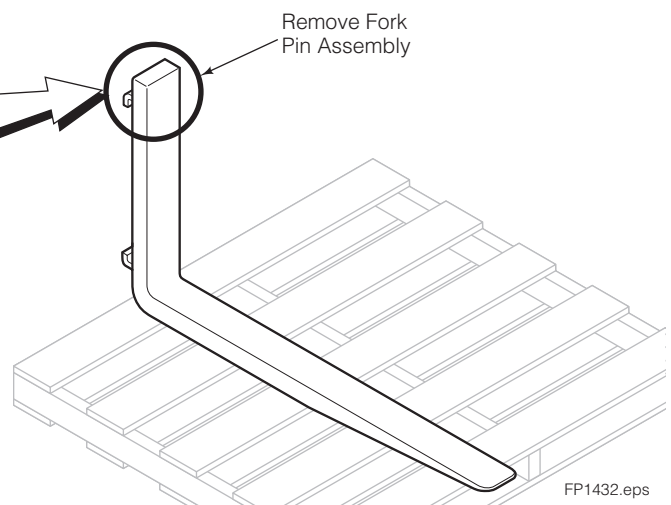
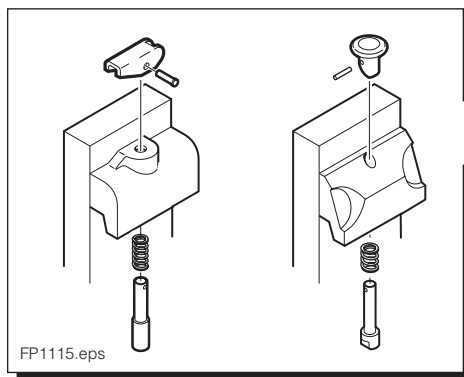

7 Install forks (55K & 65K)

- A** Remove capscrews and fork carrier inner retainer sections.
- B** Install forks using a pallet or blocks. Keep feet clear of forks.
- C** Reinstall fork carrier inner retainer sections and tighten capscrews to 25 ft.-lbs. (35 Nm).

NOTE: See illustration below to position inner retainers for various fork widths.



WARNING: Usable fork length must not exceed 60 in. (1500 mm).

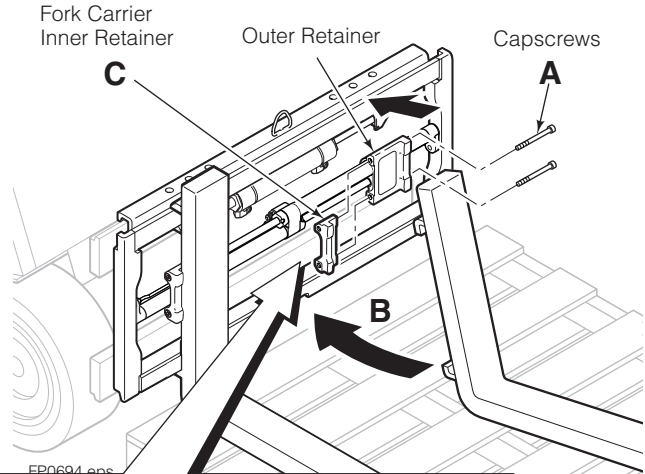

RH Front Views

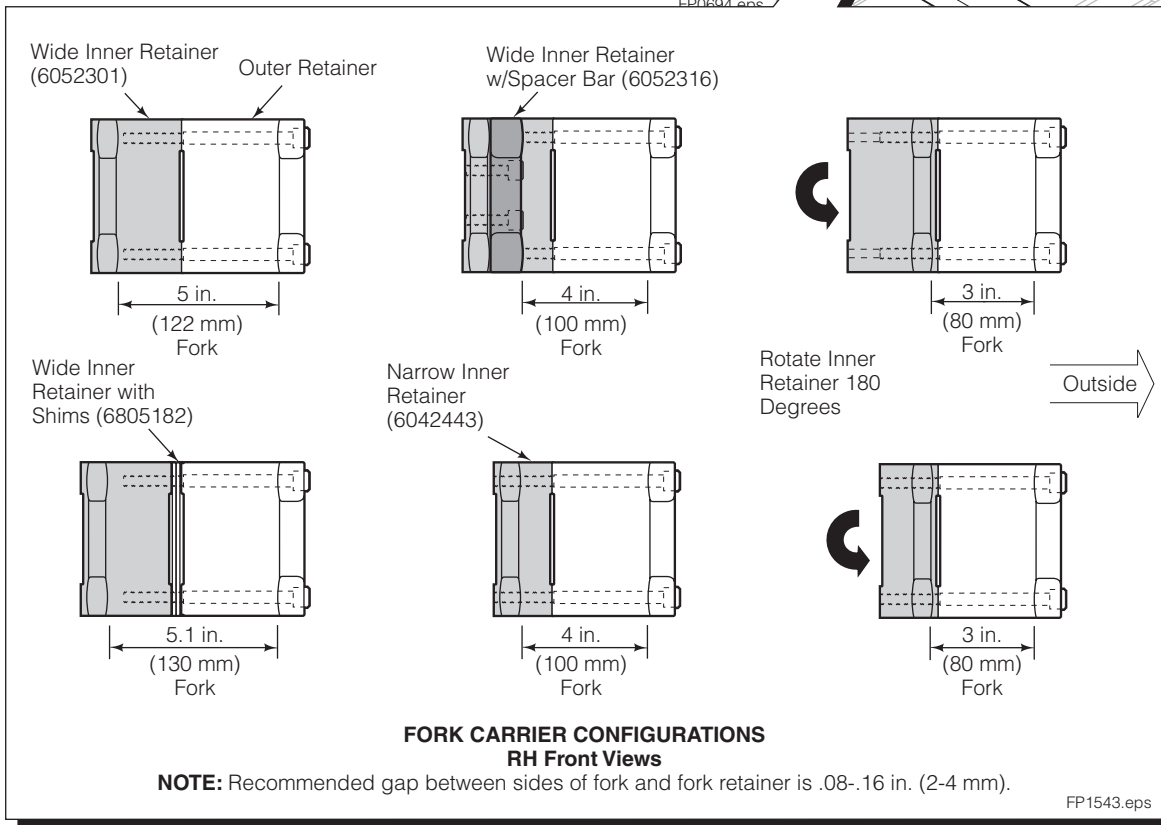

INSTALLATION

8 Install forks (100K, 120K, 150K, 165K)

- A** Remove capscrews and fork carrier inner retainer sections.
- B** Install forks using a pallet or blocks. Keep feet clear of forks.
- C** Reinstall fork carrier inner retainer sections and tighten capscrews to 50 ft.-lbs. (65 Nm).

NOTE: See illustration below to position inner retainers for various fork widths.



WARNING: Usable fork length must not exceed 60 in. (1500 mm).

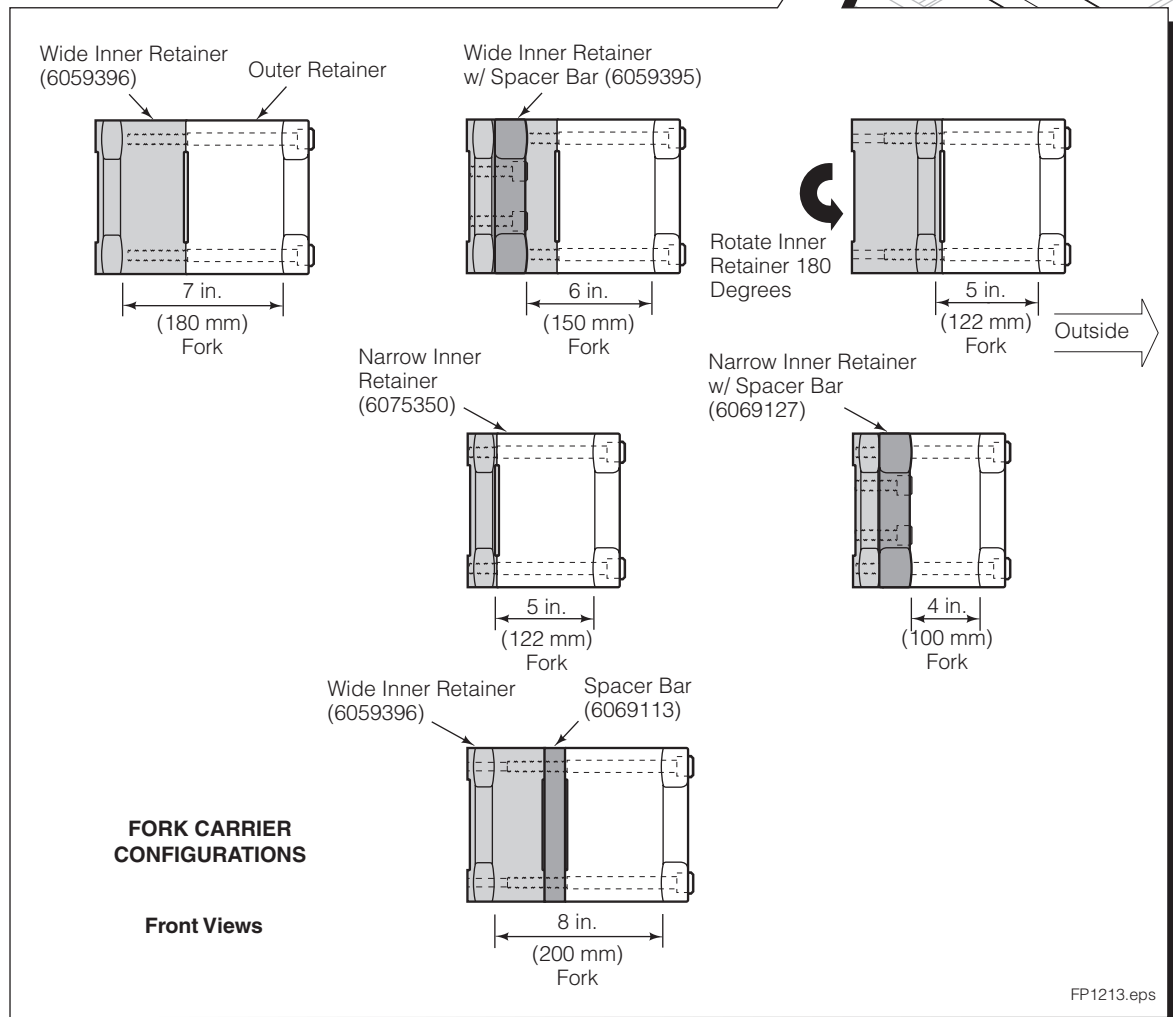
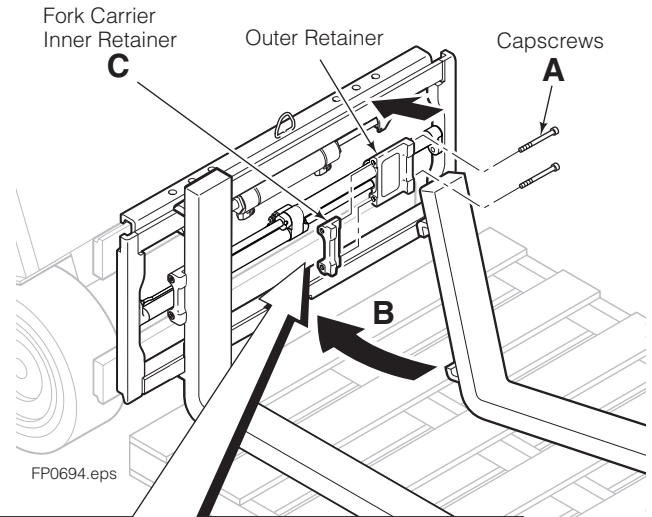

FP1213.eps

9 Lubrication

Fork Positioner is prelubed at the factory and requires no lubrication for installation. Use graphite dry lube for fork bars as required ('Slip Plate Aerosol', 'GraphoKote' or equivalent).

After use, lubricate fork positioner as described in *Periodic Maintenance* Section in this manual.

10 Cycle Fork Positioner functions

- Open and close forks several times. Check for smoothness and equal movement (see Step 10 for adjustment).
- Check for operation in accordance with ANSI s(ISO) standards.
- Check for leaks at fittings, valve, cylinders.

AUXILIARY VALVE FUNCTIONS

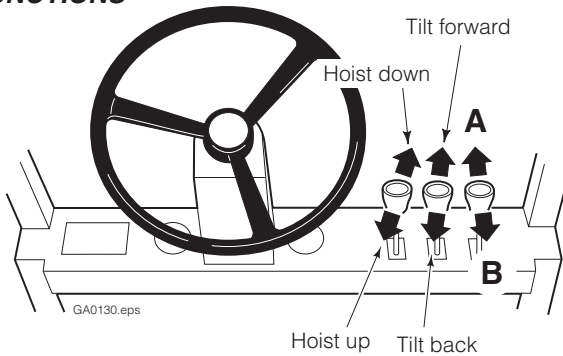

WARNING: Truck control handle and attachment function activation shown here conforms to ASME/ANSI B56.1 recommended practices. Failure to follow these practices may lead to serious bodily injury or property damage. End user, dealer and OEMs should review any deviation from the practices for safe operation.

FORK POSITIONING

- A** Spread Forks
- B** Close Forks

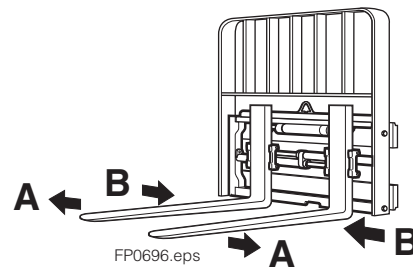

11 Adjust forks for equal movement (if required)

NOTE: Attachment is factory adjusted for equal fork movement when operated at recommended pressure and flow rate.

- Locate flow restrictors at each end. Loosen jam nuts and screw both flow restrictors in until they bottom. Screw each restrictor out (CCW) three (3) turns.
- Open forks fully, then close. Look for unequal fork movement.
- On faster fork (one that bottoms first), screw flow restrictor in (CW) 1/2 turn.
- Repeat Steps B and C until fork movement is equal. Tighten jam nuts.

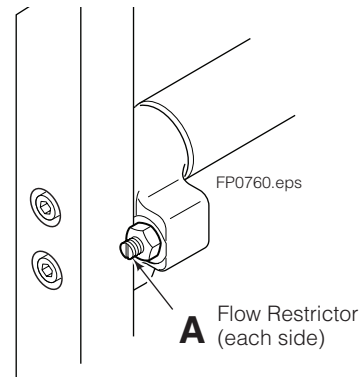

Back (Driver's) View

12 Inspect fork hooks, carriage bar clearance

NOTE: Use go/no-go Wear Gauge Part No. 209560 (Class II), 209561 (Class III) or 6104118 (Class IV).

- A** Inspect the fork lower hooks and carriage bar. If the gauge fits between the carriage bar and lower hook, repair or replacement is needed.

- B** Inspect the upper carriage bar. If the gauge arrow touches the carriage bar, repair or replacement is needed.

- C** Inspect the fork upper hooks. If the gauge arrow touches the hook, repair or replacement is needed.

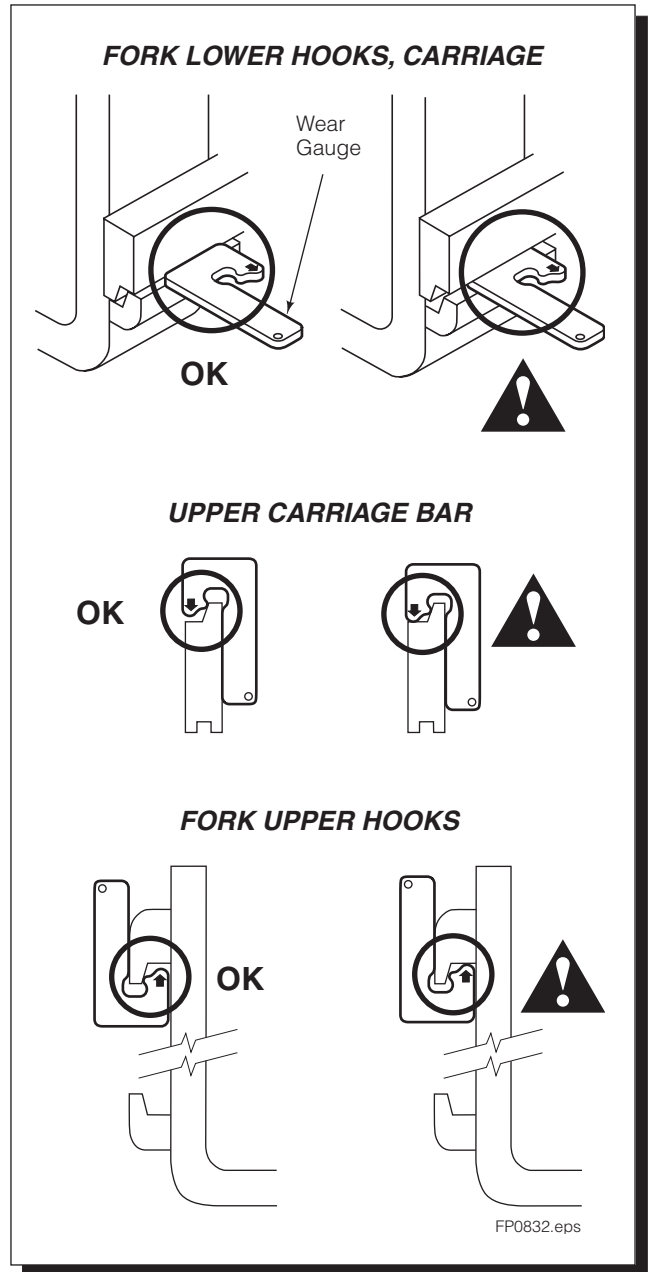



WARNING: After completing any service procedure, always test the fork positioner through five complete cycles to make sure the attachment operates correctly before returning it to the job.

100-Hour

Every time the lift truck is serviced or every 100 hours of truck operation, whichever comes first, complete the following maintenance procedures:

- Check for loose or missing capscrews, worn or damaged hoses, and hydraulic leaks.
- Inspect sideshifter lower hooks for wear and proper clearance.
- Tighten fork positioner mounting flange capscrews:
55K, 65K – 50 ft.-lbs. (65 Nm)
100K, 120K, 150K, 165K – 120 ft.-lbs. (165 Nm)
- Tighten fork carrier capscrews:
55K, 65K – 25 ft.-lbs. (35 Nm)
100K, 120K, 150K, 165K – 50 ft.-lbs. (65 Nm)
- Tighten fork positioner cylinder rod anchor plugs:
55K, 65K – 50 ft.-lbs. (65 Nm)
100K, 120K, 150K, 165K – 100 ft.-lbs. (135 Nm)
- Tighten lower hook capscrews to:
Class II/III – 120 ft.-lbs. (165 Nm)
Class IV – 235 ft.-lbs. (320 Nm)

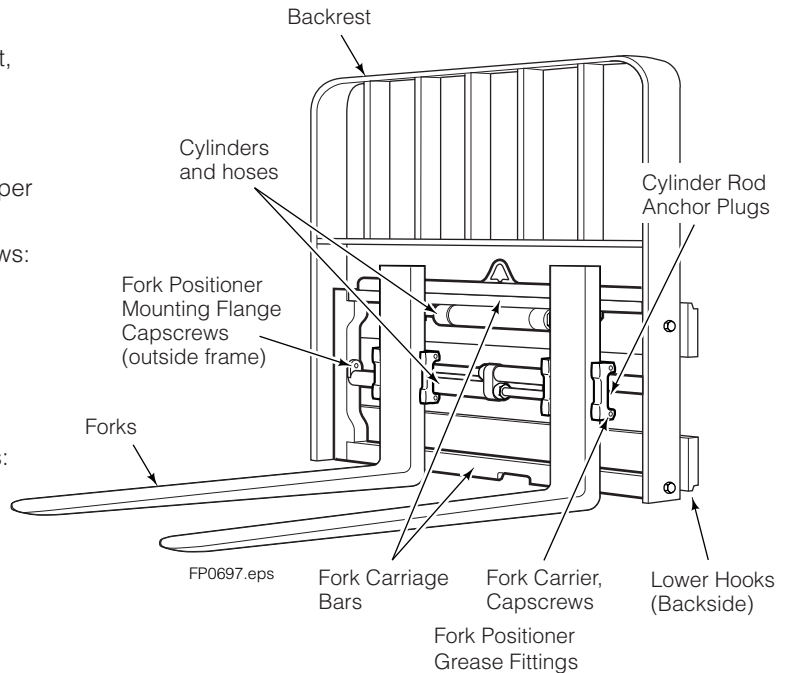

300-Hour

After each 300 hours of truck operation, in addition to the 100-hour maintenance, perform the following procedures:

- Tighten Cascade backrest capscrews to 145 ft.-lbs. (195 Nm).
- Apply general-purpose chassis grease to sideshifter upper bearing grease fittings, fork carrier grease fittings and sideshifter lower bearings.
- Apply graphite dry-lube to fork carriage bars as required ('Slip Plate Aerosol', 'GraphoKote' or equivalent).

1000-Hour

After each 1000 hours of truck operation, in addition to the 100 and 300-hour maintenance, perform the following procedures:

- Inspect fork carriers for looseness on cylinders and cylinder rod anchors for excessive end play (see Service Manual for repair procedures).

NOTE: Cylinder rod anchors operate with a loose clearance.

- Inspect sideshifter upper and lower bearings for wear. If any bearing is worn to less than 3/32 in. (2.5 mm) thickness replace the entire bearing set.

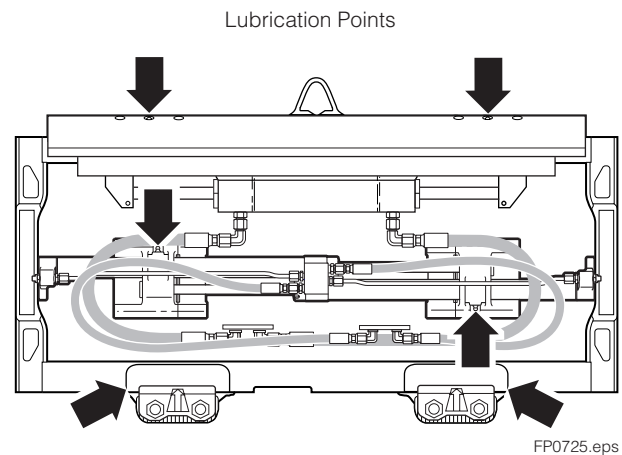

Back (Driver's View)

2000-Hour

After 2000 hours of truck operation, in addition to the 100, 300 and 1000-hour maintenance, forks in use shall be inspected at intervals of not more than 12 months (for single shift operations) or whenever any defect or permanent deformation is detected. Severe applications will require more frequent inspection.

Fork inspection shall be carried out by trained personnel to detect any damage that might impair safe use. Any fork that is defective shall be removed from service. Reference ANSI B56.1-2005.

Inspect for the following defects:

- Surface cracks
- Straightness of blade and shank
- Fork angle
- Difference in height of fork tips
- Positioning lock
- Wear on fork blade and shank
- Wear on fork hooks
- Legibility of marking

NOTE: Fork Safety Kit 3014162 contains wear calipers, inspection sheets and safety poster. Also available is fork hook & carriage wear gauge 209560 (Class II), 209561 (Class III) and 6105118 (Class IV).

Product Identification

The assembly part number is stamped on the rear of the LH fork carrier and must be provided when ordering replacement parts.

Sticker showing operating pressure, phone numbers for service & parts

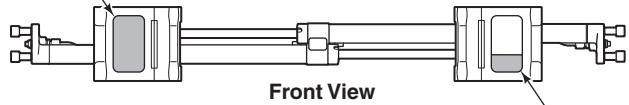

Front View

Patent Sticker

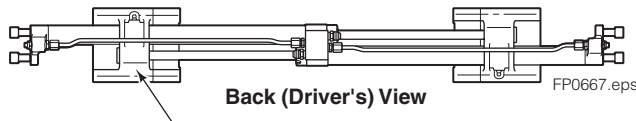

Back (Driver's) View

FP0667.eps

Assembly Part Number
(on LH fork carrier)

Recommended Spare Parts

FORK POSITIONER				UNITS SERVICED		
55K PART NO.	65K PART NO.	100K, 120K, 150K, 165K PART NO.	DESCRIPTION	1-5	6-19	20-50
				QTY.	QTY.	QTY.
6055389	6055389	6081752	Cylinder Service Kit	0	4	6
6055390	6055390	6081751	Bearing Service Kit-Composite	1	2	4
6055391	6055391	6081749	Bearing Service Kit-Bronze	1	2	4
6039245	6039245	6059383	Mounting Shims	8	12	16

- Refer to part number stamped on part or supply serial number stamped on sidershifter frame when purchasing these parts.

Publications

PART NO.	DESCRIPTION
6054167	User Manual
6053927	Service Manual
679929	Tool Catalog
673964	Literature Order Form

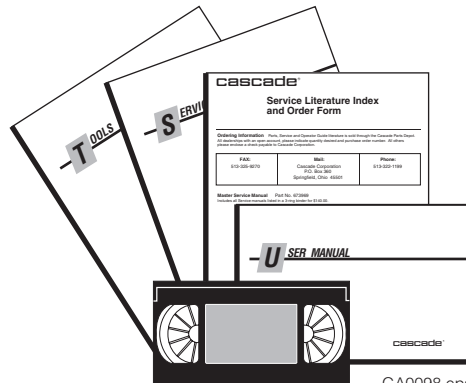

GA0098.eps

BLANK

Do you have questions you need answered right now? Call your nearest Cascade Parts Department. Visit us online at www.cascorp.com

AMERICAS

Cascade Corporation Parts Sales

2501 Sheridan Ave.
Springfield, OH 45505
Tel: 888-CASCADE (227-2233)
Fax: 888-329-0234

Cascade Canada Inc.

5570 Timberlea Blvd.
Mississauga, Ontario
Canada L4W-4M6
Tel: 905-629-7777
Fax: 905-629-7785

Cascade do Brasil

Rua João Guerra, 134
Macuco, Santos - SP
Brasil 11015-130
Tel: 55-13-2105-8800
Fax: 55-13-2105-8899

EUROPE-AFRICA

Cascade Italia S.R.L. European Headquarters

Via Dell'Artigianato 1
37050 Vago di Lavagno (VR)
Italy
Tel: 39-045-8989111
Fax: 39-045-8989160

Cascade (Africa) Pty. Ltd.

PO Box 625, Isando 1600
60A Steel Road
Sparton, Kempton Park
South Africa
Tel: 27-11-975-9240
Fax: 27-11-394-1147

ASIA-PACIFIC

Cascade Japan Ltd.

2-23, 2-Chome,
Kukuchi Nishimachi
Amagasaki, Hyogo
Japan, 661-0978
Tel: 81-6-6420-9771
Fax: 81-6-6420-9777

Cascade Korea

121B 9L Namdong Ind.
Complex, 691-8 Gojan-Dong
Namdong-Ku
Inchon, Korea
Tel: +82-32-821-2051
Fax: +82-32-821-2055

Cascade-Xiamen

No. 668 Yangguang Rd.
Xinyang Industrial Zone
Haicang, Xiamen City
Fujian Province
P.R. China 361026
Tel: 86-592-651-2500
Fax: 86-592-651-2571

Cascade India Material Handling Private Limited

No 34, Global Trade Centre
1/1 Rambaugh Colony
Lal Bahadur Shastri Road,
Navi Peth, Pune 411 030
(Maharashtra) India
Phone: +91 020 2432 5490
Fax: +91 020 2433 0881

Cascade Australia Pty. Ltd.

1445 Ipswich Road
Rocklea, QLD 4107
Australia
Tel: 1-800-227-223
Fax: +61 7 3373-7333

Cascade New Zealand

15 Ra Ora Drive
East Tamaki, Auckland
New Zealand
Tel: +64-9-273-9136
Fax: +64-9-273-9137

Sunstream Industries Pte. Ltd.

18 Tuas South Street 5
Singapore 637796
Tel: +65-6795-7555
Fax: +65-6863-1368

