



INSTALLATION & OPERATION

Stationary Load Inverter

Manual Number 6099892

**cascade[®]
corporation**

Cascade is a Registered Trademark of Cascade Corporation

Contents

Page Number

INSTALLATION INSTRUCTIONS

- **Home Position.....1**
- **Preparation.....2**
- **Electrical.....2**
- **Hydraulic2**
- **Floor Area.....2**
- **Installation.....2 & 3**
- **Periodic Maintenance.....3**

OPERATION INSTRUCTIONS

- **About the Unit.....4**
 - **Safety Precautions4**
 - **Safety Features.....4**
 - **Operating Instructions.....5**
 - **Operating Sequence.....5 & 6**
-

Home Position

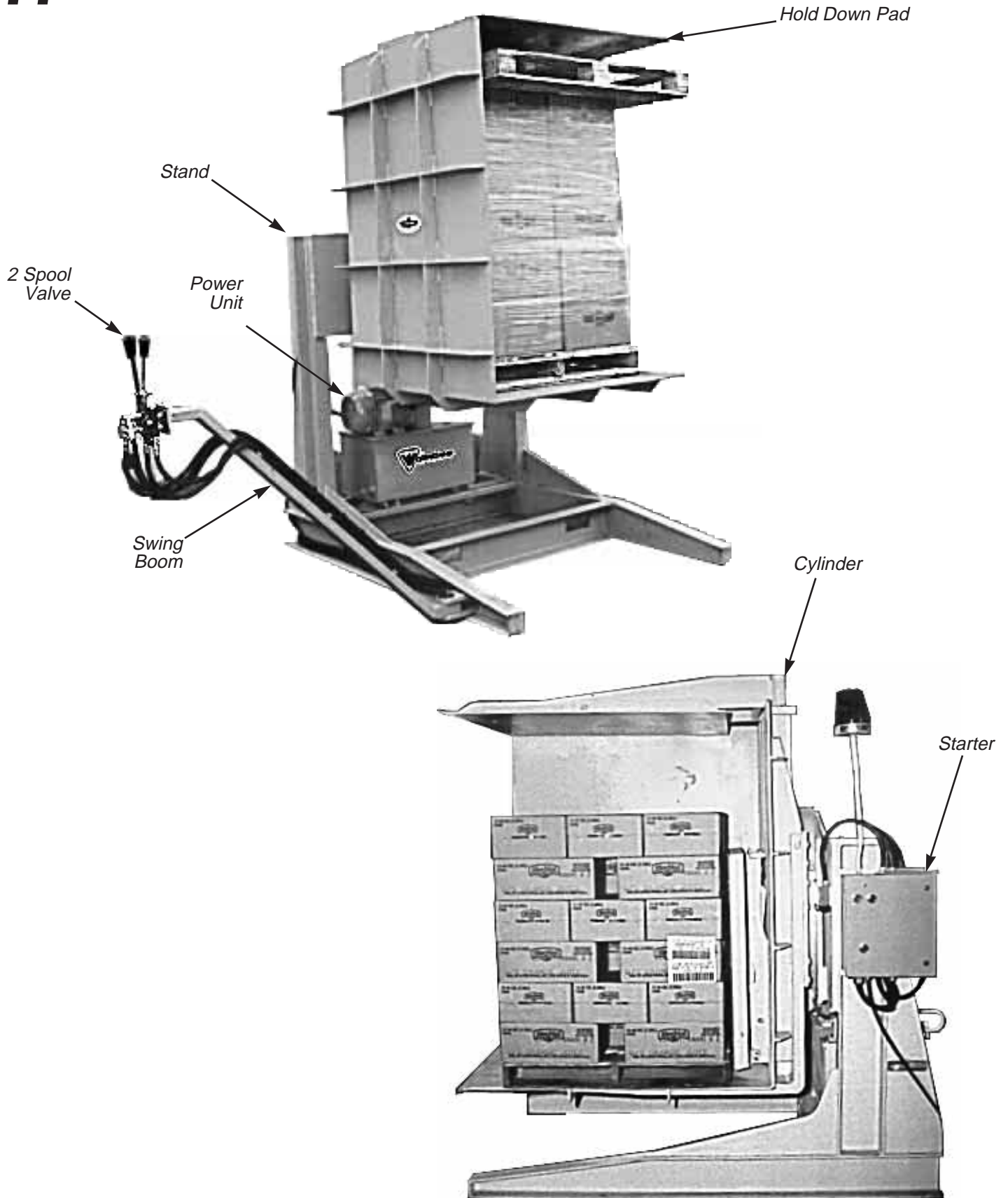

Preparation

1. The unit has been factory tested and inspected thoroughly before shipping for proper performance.
 - Electrically & Hydraulically
 - The Electric Circuit is complete to the magnetic starter
 - The Hydraulic Circuit is also complete from the pump to the Control Valve.
2. Inspect the unit for loose or disconnected wires during shipping.
3. Inspect the whole station for loose screws or components.

Electrical

The Stationary Load Inverter has been factory wired to operate at 220V, 440V or 575 Volts, three phase input as specified when ordered. Use of incorrect Voltage will result in major component damage.



CAUTION:

Check Voltage Tag inside the Magnetic Starter Box to assure the unit is wired to match your power supply voltage

A certified Electrician is recommended for installation of power supply, from your source. (Wall mounted disconnect is recommended) to the Magnetic Starter.

Hydraulic

Use 10 wt Hydraulic Oil (Petroleum based).
The required volume is 20 Gallon.

Floor Area

The standard Stationary Load Inverter requires an area of approximately 8' deep x 8' wide

Installation

1. The Stationary Load Inverter can be mounted in one location or operate at several locations. It is complete with convenient fork pockets for easy transportation to destination.
 2. A certified Electrician is recommended for installation of the power supply from your source (Wall mounted disconnect) to the Magnetic Starter.
- *** Magnetic starter is mounted on side of stationary stand.

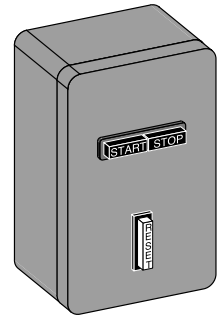

CAUTION:

Check Voltage Tag inside the Starter Box to assure proper Voltage.

- ** Instructions for Magnetic Starter hook up to fusible disconnect is included in starter box.

3. Check fluid level on sight gauge to ensure Oil is present before start up.



CAUTION:

Before start up continuous operation of the Load Inverter, the motor/pump must be checked for correct rotational direction. The motor/pump must rotate in the direction indicated by the arrow on the side of the pump as shown. Remove the inspection cover motor/pump adapter to observe rotation.

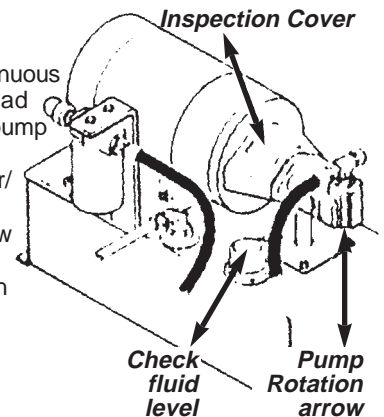

WARNING:

Unplug the power cord before start up any service on the main switch.

Start the motor for **one** second only. If the rotation is incorrect, switch any two wires at the main switch input terminals. Start the motor briefly again to confirm correct rotation. Replace the inspection cover on the motor/pump adapter.

Note: If the pump is not rotating in the right direction, hydraulic pressure will not be supplied to the unit.

Installation

4. The hydraulic circuit is complete, once the electric hook up is okay, the unit is ready for operation.
 - The single pressure relief valve is factory set @ 1750 PSI. It can be adjusted for higher or lower pressure if desired.
 - The unit is also equipped with 180° Stop Group. Once the hard stop comes in contact with the Hydraulic Valve the unit will stop rotate. Set to be in horizontal position to ground.
 - Unit with Pendant Control is equipped with 2 Unit switches. Once the activator comes in contact with the switch the unit will stop rotating.
5. Operate the Load Inverter through several cycles to make sure it operates correctly before start up in normal operation.

Try several cycles unloaded/then loaded.

6. Start/Stop Push button is located on the Magnetic Starter Box c/w Emergency Stop & Reset.

Note:

In Case of a Circuit overload the magnetic starter will trip & the motor will shut down.

Press Reset Button & restart.
If problem continues consult your Electrician.

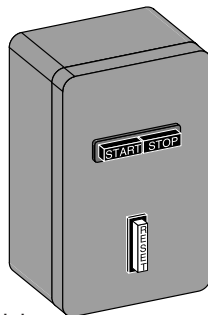

7. **2-Spool Valve mounted on Swing Boom.**
 - Push/Pull - 1st leverOpen/Close
 - Push/Pull - 2nd lever.....Rotate CW/Anti CW

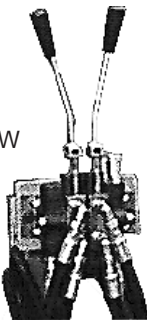

- Pendant Control Units

- Stop/Start button located on Magnetic Starter as above
- Pendant on 50' cable
- Open/Close button
- Rotate Left/Rotate Right Button

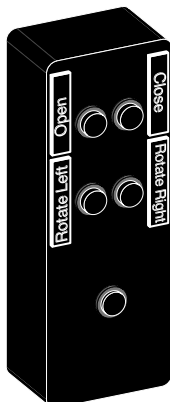

Periodic Maintenance

Daily

- Check Oil level on sight Gauge
- Check for any hydraulic leaks on cylinder and hoses.
- Remove all broken boards and debris from immediate workup area of unit.

100 Hours Maintenance

- Check Hydraulic Oil level in reservoir.
- Inspect all:**
- Hoses
- Check Valve
- Cylinder
- Motor
- Drive Box
- (for leaks, damage or wear — Change if necessary)
- Inspect the Cylinder Anchor Nuts for correct hold.
- Lubricate the Ring Gear.
- Lubricate the Stabilizer Arm Carrier Bearings.

Operating Instructions

About the Unit

- The Stationary Load Inverter is designed with its own hydraulic and electric circuit.
- It is equipped with:
 - 1....Magnetic stop/start c/w emergency stop and resetbutton
 - 2....180° Stop Group
 - 3....Hydraulic Power Unit (Voltage as requested)
 - 4....2 Spool Valve for manual operation at the unit or4 Button Pendant Control to operate from a remotelocation.
 - 5....Adjustable Relief Valve for pressure control.Factory set @ 1750 PSI
 - 6 ...The Unit is fully tested hydraulically and electricallybefore leaving factory.Once on site it is recommended youcontact your electrician for installation.(See Installation Instructions)

NOTE:

Please note all operations described applies to both the 2 spool valve unit as the pendant control unit.

***** The Pendant Control Unit will not open if stopped at any point in the rotation circuit. (Only in 180° position.)*****

Safety Precautions



Be sure no one is standing on the Stationary Load Inverter or in the area covered by the radius when the unit rotates.



Operation of the Stationary Load Inverter must be by a trained operator. Read and follow all directions as outlined in the manual.

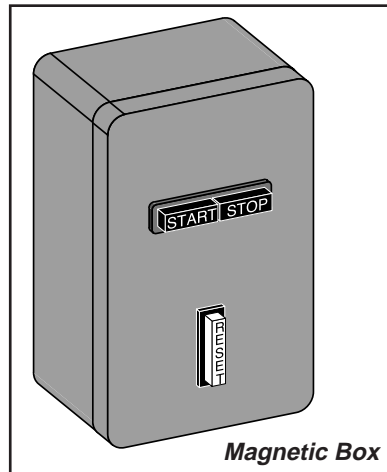

Magnetic Box

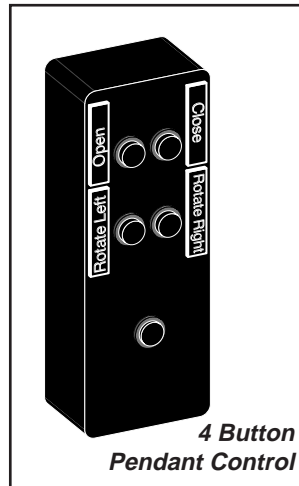

4 Button Pendant Control

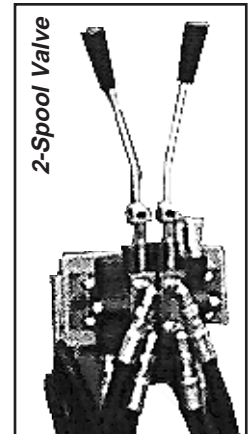

2-Spool Valve

Safety Features

- 1) The Unit can be stopped during any phase in the operation by pressing the emergency stop button.
- 2) It can also be stopped by releasing the control lever to its normal position.
- 3) Unit is equipped with a Magnetic Starter. If there is any electrical problem in the circuit the motor will shut down. Press Reset Button and then restart. If problem persists — consult your electrician.

Operating Instructions

To familiarize the operator with the operating sequence, it is recommended that the unit be operated several cycles without a load.



Be sure the area is clear of any persons or other obstructions.

- 1) Press start button on the starter panel, the power unit will come on.



Be sure that the loading platform is in the Home Position. (Parallel to ground)

- 2) Place the load onto the bottom platform of the unit.
- 3) Insert the desired pallet on top of the load.
- 4) Pull the 1st lever until the load is clamped securely.

****NOTE:**

Unit equipped with adjustable relief in clamp circuit, if load is not secured after clamping, consult technician to adjust clamp pressure higher or if load is being crushed, adjust pressure lower.

- 5) Once the load is clamped, pull on the 2nd lever to rotate the load clockwise. The unit will stop once the hard stop comes in contact with the hydraulic stop group in the 180° position.



Do not try to unclamp load during rotation.

— **Unclamping must only be done when load is in Vertical Position, unless unit is so designed.**

- 6) Push on the 1st lever to release the load.
- 7) Remove the top pallet.
- 8) Remove the load on the desired pallet.
- 9) Continue the process from # 2.
- 10) At # 5 push on the 2nd lever to rotate unit anti clockwise.

Operating Sequence



2) Approach

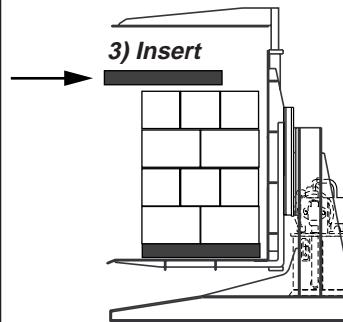
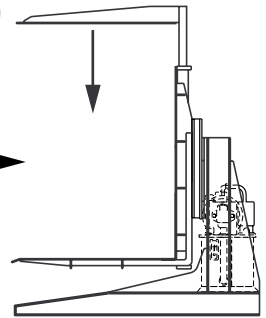

3) Insert

4) Clamp

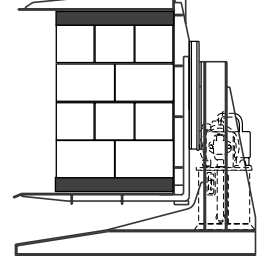

5) Rotate

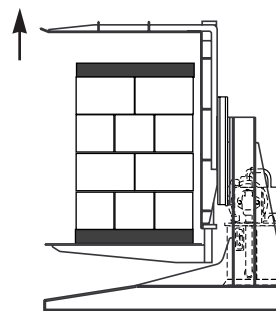
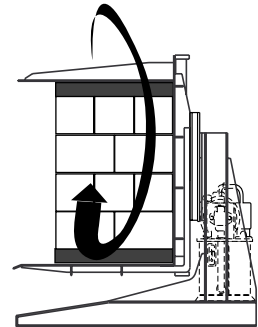

6) Unclamp

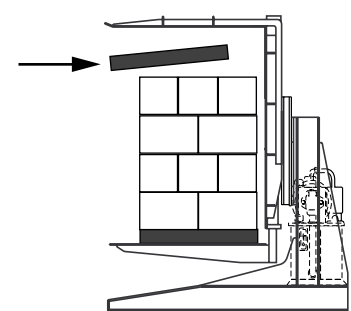

7) Remove Pallet

8) Remove Load

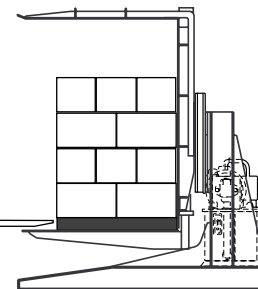

Operating Sequence

- 1) - Start the hydraulic Power Unit
 - Be sure the loading platform is in the horizontal position. Approach the unit with load from the front. Deposit Load onto platform.

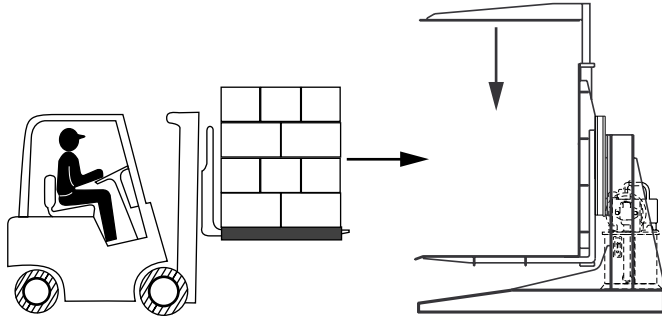

Back Lift Truck away.

- 2) - Insert the desired pallet, (i.e. pallet you want to ship Load on) on top of the Load. This can be done manually or by using the Lift Truck.

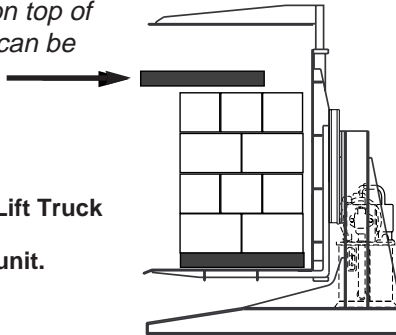

If you use the Lift Truck back it away stand clear of unit.

- 3) - Move over to the control lever. Pull the first lever until the load is securely clamped.

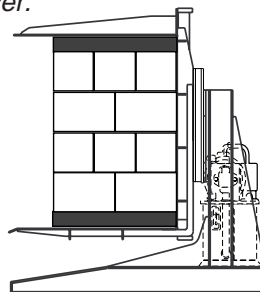

Be sure the load is clamped before the next operation.

- 4) - Pull on the second lever to rotate the load clockwise. The Unit will stop at 180°. The Load is now deposited on the desired pallet.

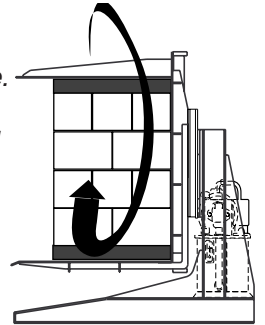

- 5) - Push on the 1st lever to unclamp the load

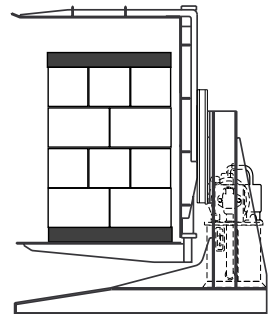

- 6) - Remove top pallet and store away as desired.

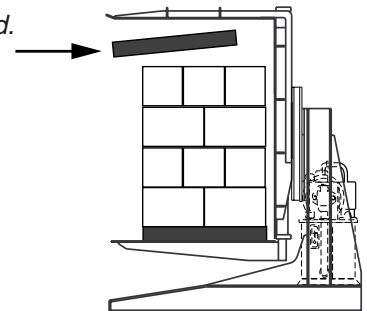

- 7) - The load is now ready for pick-up on the desired pallet. Approach the load with **caution** insert forks into pallet. Retrieve the load.

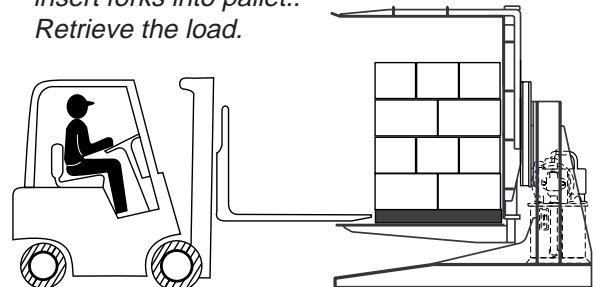

Do you have questions you need answered right now? Call your nearest Cascade Service Department. Visit us online at www.cascorp.com

AMERICAS

**Cascade Corporation
U.S. Headquarters**
2201 NE 201st
Fairview, OR 97024-9718
Tel: 800-CASCADE (227-2233)
Fax: 888-329-8207

Cascade Canada Inc.
5570 Timberlea Blvd.
Mississauga, Ontario
Canada L4W-4M6
Tel: 905-629-7777
Fax: 905-629-7785

Cascade do Brasil
Rua João Guerra, 134
Macuco, Santos - SP
Brasil 11015-130
Tel: 55-13-2105-8800
Fax: 55-13-2105-8899

EUROPE-AFRICA

**Cascade Italia S.R.L.
European Headquarters**
Via Dell'Artigianato 1
37050 Vago di Lavagno (VR)
Italy
Tel: 39-045-8989111
Fax: 39-045-8989160

Cascade (Africa) Pty. Ltd.
PO Box 625, Isando 1600
60A Steel Road
Sparton, Kempton Park
South Africa
Tel: 27-11-975-9240
Fax: 27-11-394-1147

ASIA-PACIFIC

Cascade Japan Ltd.
2-23, 2-Chome,
Kukuchi Nishimachi
Amagasaki, Hyogo
Japan, 661-0978
Tel: 81-6-6420-9771
Fax: 81-6-6420-9777

Cascade Korea
121B 9L Namdong Ind.
Complex, 691-8 Gojan-Dong
Namdong-Ku
Inchon, Korea
Tel: +82-32-821-2051
Fax: +82-32-821-2055

Cascade-Xiamen
No. 668 Yangguang Rd.
Xinyang Industrial Zone
Haicang, Xiamen City
Fujian Province
P.R. China 361026
Tel: 86-592-651-2500
Fax: 86-592-651-2571

**Cascade India Material
Handling Private Limited**
No 34, Global Trade Centre
1/1 Rambaugh Colony
Lal Bahadur Shastri Road,
Navi Peth, Pune 411 030
(Maharashtra) India
Phone: +91 020 2432 5490
Fax: +91 020 2433 0881

Cascade Australia Pty. Ltd.
1445 Ipswich Road
Rocklea, QLD 4107
Australia
Tel: 1-800-227-223
Fax: +61 7 3373-7333

Cascade New Zealand
15 Ra Ora Drive
East Tamaki, Auckland
New Zealand
Tel: +64-9-273-9136
Fax: +64-9-273-9137

**Sunstream Industries
Pte. Ltd.**
18 Tuas South Street 5
Singapore 637796
Tel: +65-6795-7555
Fax: +65-6863-1368

