

# **U**SER MANUAL

## ***G-Series Fork Positioner***

**Models: 55G-FPB, 55G-FPS  
100G-FBP, 100G-FPS**

**Manual Number 6047782-R1**

**cascade<sup>®</sup>  
corporation**

Cascade is a Registered Trademark of Cascade Corporation

# **C**ONTENTS

	<b>Page</b>
<b>INTRODUCTION</b>	
Special Definitions	2
<b>OPERATION</b>	
Safety Rules	3
Industrial Lift Trucks	3
Handling Loads	4
Fork Position & Sideshift Operation	4
Daily Inspection	5
Safe Operation and Maintenance	6
<b>TRUCK REQUIREMENTS</b>	
Truck Settings	7
<b>HYDRAULIC SUPPLY</b>	
Recommended Hydraulic Supply	8
<b>INSTALLATION</b>	
Installation Procedures	9
<b>PERIODIC MAINTENANCE</b>	
100-Hour Maintenance	13
300-Hour Maintenance	13
1000-Hour Maintenance	13
<b>CONTACTING CASCADE</b>	back cover

# INTRODUCTION

This User Manual is for the Cascade G-Series Fork Positioner. Contents include an Operation Guide, Installation Instructions and Periodic Maintenance. All specifications are shown in Metric units where applicable.

**IMPORTANT:** The G-Series Fork Positioner is metric. Supply fittings adapted as required for application.

## Special Definitions

The statements shown appear throughout this Manual where special emphasis is required. Read all WARNINGS and CAUTIONS before proceeding with any work. Statements labeled IMPORTANT and NOTE are provided as additional information of special significance or to make the job easier.



**WARNING** – A statement preceded by WARNING is information that should be acted upon to prevent **bodily injury**. A WARNING is always inside a ruled box.



**WARNING:** Rated capacity of the truck/attachment combination is a responsibility of the original truck manufacturer and may be less than shown on the attachment nameplate. Consult the truck nameplate.

**WARNING:** Do not operate this attachment unless you are a trained and authorized lift truck driver.

**CAUTION** – A statement preceded by CAUTION is information that should be acted upon to prevent machine damage.

**IMPORTANT** – A statement preceded by IMPORTANT is information that possesses special significance.

**NOTE** – A statement preceded by NOTE is information that is handy to know and may make the job easier.

# OPERATION

This Section contains operating instructions for the Cascade G-Series Fork Positioner. It will help you avoid common errors which often cause damage to the equipment or product being handled.

This information is intended to simplify operator understanding about effective and safe Fork Positioner use and operation. Read this information thoroughly before operating the Attachment. Be sure you know and understand all operating procedures and safety precautions. If you have any questions, or don't understand a procedure, ask your supervisor.

**Emphasize Safety!** Most accidents are caused by operator carelessness or misjudgement. You must watch for poorly maintained equipment and hazardous situations and correct them.

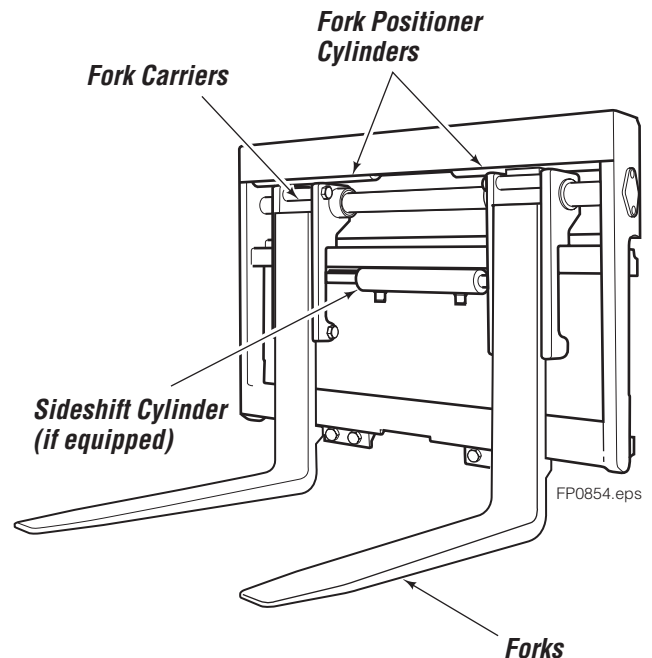

# OPERATION

## Safety Rules – Industrial Lift Trucks

No riders



No reaching through mast



No standing under load



GA0047.iii

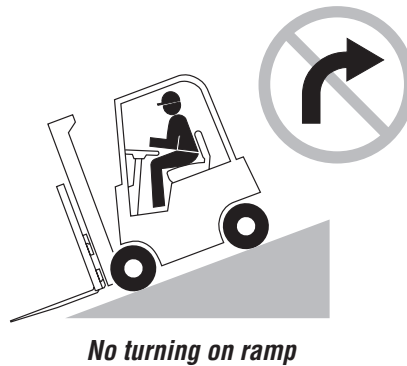
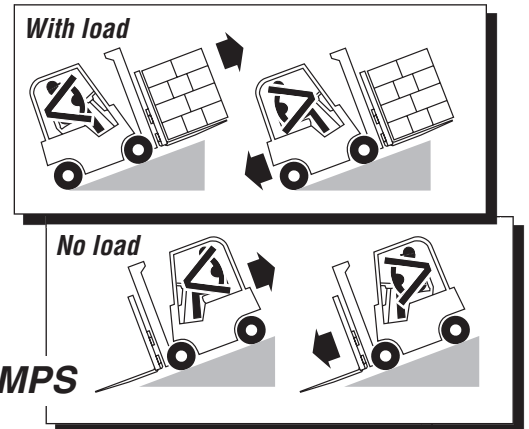
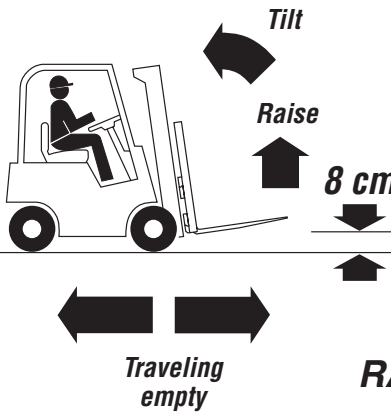
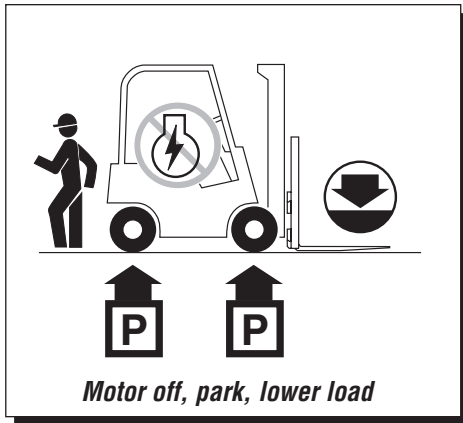

GA0048.iii

<p><b>TRAFFIC</b></p> <p><b>Observe</b></p> <p><b>Wet floors</b></p>			<p><b>Workers</b></p> <p><b>Bumps</b></p>	<p><b>Stops</b></p> <p><b>Dips</b></p>	<p><b>Slow for two-way traffic</b></p>	<p><b>Sound horn, slow at intersection</b></p>	<p><b>Sound horn, slow at corner</b></p>
--	--	--	---	--	--	--	--

# OPERATION

## Safety Rules – Handling Loads

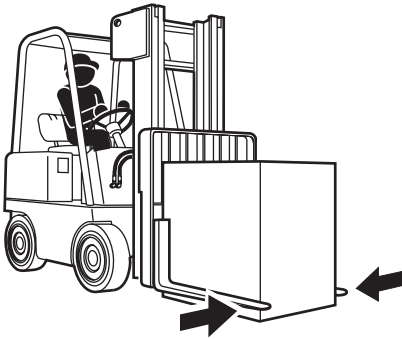

**CAUTION: Do not put side loads on forks.**

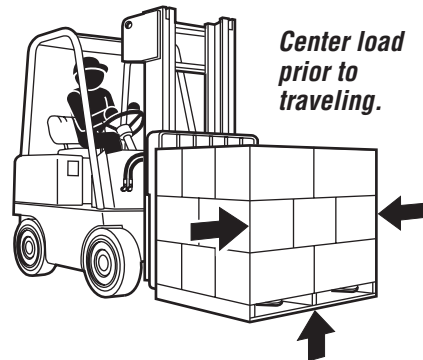

**Center load prior to traveling.**

**Raise load prior to sideshifting.**

**Limit sideshifting with raised load.**

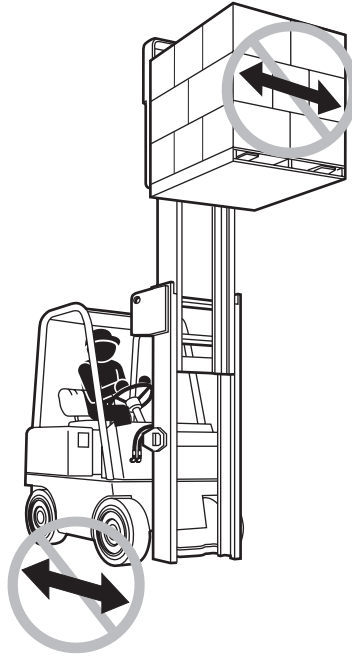

**Limit truck movement with raised load.**

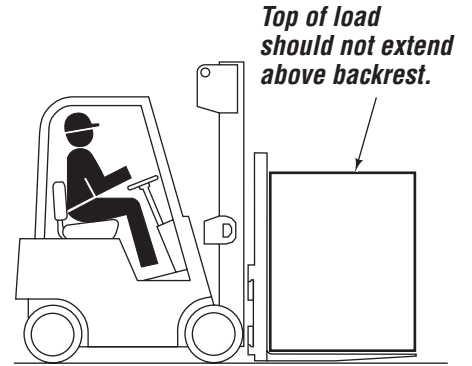

**Top of load should not extend above backrest.**

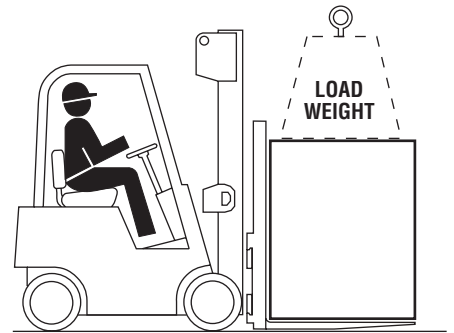

FP0174.eps

**Load weight must not exceed combined truck/attachment capacity (see truck nameplate).**

**Total fork capacity (LH + RH fork) must be greater than load weight. Check capacity stamp on forks.**

### Fork Position & Sideshift Operation

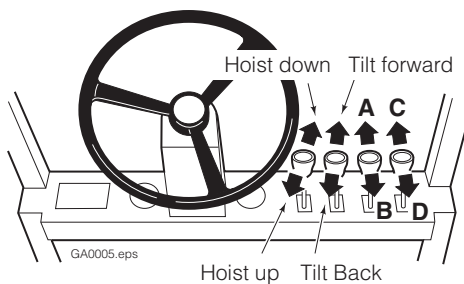

**AUXILIARY VALVE FUNCTIONS**

#### FORK POSITION

- A Open/Spread Forks
- B Close forks

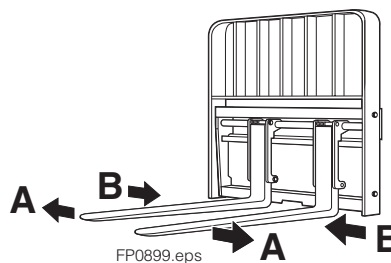

FP0899.eps

#### FORK POSITION & SIDESHIFT

- A Sideshift Left
- B Sideshift Right
- C Open/Spread Forks
- D Close forks

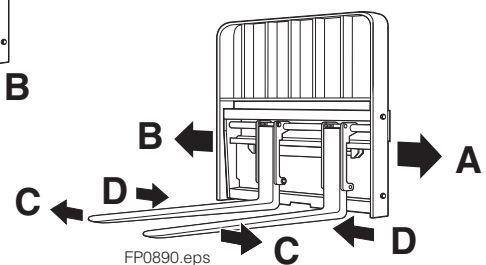

FP0890.eps

# OPERATION

## Daily Inspection

Check items shown each day. Report problems to your supervisor. See Service Manual for troubleshooting and repair procedures.

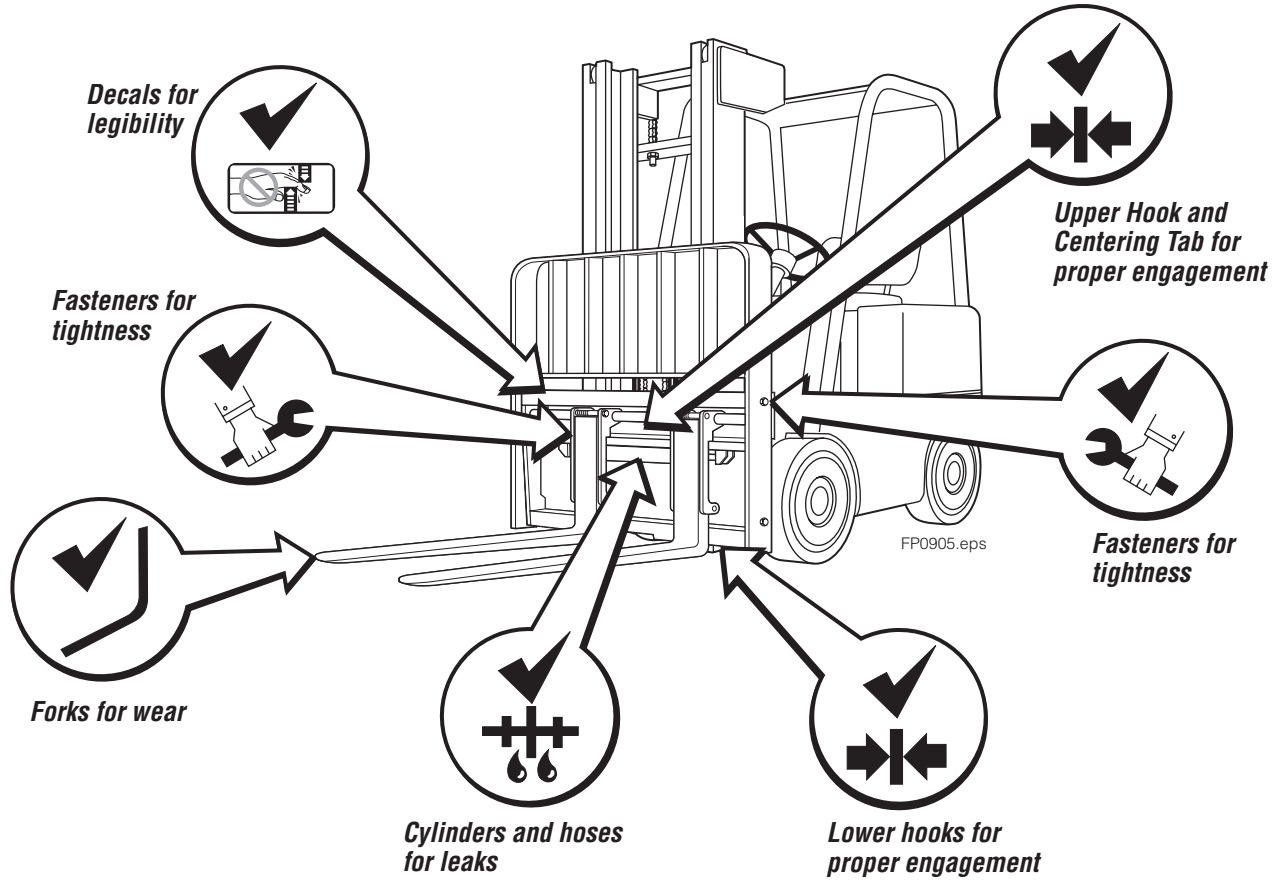



# SAFE OPERATION AND MAINTENANCE

## Industrial Trucks and Attachments



**WARNING:** The safe operation and maintenance of industrial trucks is regulated by Occupational Safety and Health (OSHA) regulations 1910.178 and American National Standards Institute (ANSI) Safety Standard for Powered Industrial Trucks, ANSI B56.1. When operating and maintaining industrial trucks equipped with attachments you should pay particular attention to the following sections of these regulations. You should be familiar with **all** sections of these regulations. **Ask your employer for the complete regulations.**

### General Requirement

Modifications and additions which affect capacity and safe operation shall not be performed by the customer or user without manufacturers prior written approval. Capacity, operation and maintenance instruction plates, tags or decals shall be changed accordingly.

If the truck is equipped with front-end attachments other than factory installed attachments, the user shall request that the truck be marked to identify the attachments and show the appropriate weight of the truck and attachment combination at maximum elevation with load laterally centered.

The user shall see that all nameplates and markings are in place and maintained in a legible condition.

### Safety Guards

If the type of load presents a hazard, the user shall equip fork trucks with a vertical load backrest extension in accordance with the following:

All new powered industrial trucks acquired and used by an employer after February 15, 1972 shall meet the design and construction requirements for powered industrial trucks established in the "American National Standard for Powered Industrial Trucks, Part II, ANSI B56.1", except for vehicles intended primarily for earth moving or over-the-road hauling.

### Operator Training

Only trained and authorized operators shall be permitted to operate a powered industrial truck. Methods shall be devised to train operators in the safe operation of powered industrial trucks.

### Truck Operations

Trucks shall not be driven up to anyone standing in front of a bench or other fixed object.

No person shall be allowed to stand or pass under the elevated portion of any truck, whether loaded or empty.

Unauthorized personnel shall not be permitted to ride on powered industrial trucks. A safe place to ride shall be provided where riding of trucks is authorized.

The employer shall prohibit arms or legs from being placed between the uprights of the mast or outside the running lines of the truck.

When a powered industrial truck is left unattended, load engaging means shall be fully lowered, controls shall be neutralized, power shall be shut off and brakes set. Wheels shall be blocked if the truck is parked on an incline.

A powered industrial truck is unattended when the operator is 25 feet or more away from the vehicle which remains in his view, or whenever the operator leaves the vehicle and it is not in his view.

When the operator of an industrial truck is dismounted and within 25 feet of the truck still in his view, the load engaging means shall be fully lowered, controls neutralized and the brakes set to prevent movement.

A safe distance shall be maintained from the edge of ramps or

platforms while on any elevated dock or platform or freight car. Trucks shall not be used for opening or closing freight doors.

A load backrest extension shall be used whenever necessary to minimize the possibility of the load or part of it from falling rearward.

### Traveling

The driver shall be required to slow down and sound the horn at cross isles and other locations where vision is obstructed. If the load being carried obstructs forward view, the driver shall be required to travel with the load trailing.

When ascending or descending grades in excess of 10 percent, loaded trucks shall be driven with the load upgrade.

On all grades the load and load engaging means shall be tilted back if applicable, and raised only as far as necessary to clear the road surface.

### Loading

Only stable or safely arranged loads shall be handled. Caution shall be exercised when handling off-center loads which cannot be centered.

Only loads within the rated capacity of the truck shall be handled.

The long or high (including multiple-tiered) loads which may affect capacity shall be adjusted.

Trucks equipped with attachments shall be operated as partially loaded trucks when not handling a load.

A load engaging means shall be placed under the load as far as possible; the mast shall be carefully tilted backward to stabilize the load.

Extreme care shall be used when tilting the load forward or backward, particularly when high tiering. Tilting forward with load engaging means elevated shall be prohibited except to pick up a load. An elevated load shall not be tilted forward except when the load is in a deposit position over a rack or stack. When stacking or tiering, only enough backward tilt to stabilize the load shall be used.

### Operation of the Truck

If at any time a powered industrial truck is found to be in need of repair, defective, or in any way unsafe, the truck shall be taken out of service until it has been restored to safe operating condition.

### Maintenance of Industrial Trucks

Any power-operated industrial truck not in safe operating condition shall be removed from service. All repairs shall be made by authorized personnel.

All parts of any such industrial truck requiring replacement shall be replaced only by parts equivalent as to safety with those used in the original design.

Industrial trucks shall not be altered so that the relative positions of the various parts are different from what they were when originally received from the manufacturer, nor shall they be altered either by the addition of extra parts not provided by the manufacturer or by the elimination of any parts. Additional counter-weighting of fork trucks shall not be done unless approved by the truck manufacturer.

Industrial trucks shall be examined before being placed in service and shall not be placed in service if the examination shows any condition adversely affecting the safety of the vehicle. Such examinations shall be made at least daily. When industrial trucks are used on a round-the-clock basis, they shall be examined after each shift. Defects when found shall be immediately reported and corrected.

# T RUCK REQUIREMENTS

## Truck Relief Setting

160 bar Recommended  
210 bar Maximum

## Truck Flow Volume <sup>①</sup>

	Min. <sup>②</sup>	Recommended	Max. <sup>③</sup>
<b>55G</b>	15 L/min.	20 L/min.	35 L/min.
<b>100G</b>	20 L/min.	30 L/min.	40 L/min.

- ① Cascade K-Series Fork Positioner/Sideshifters are compatible with SAE 10W petroleum base hydraulic fluid meeting Mil. Spec. MIL-0-5606 or MIL-0-2104B. Use of synthetic or aqueous base hydraulic fluid is not recommended. If fire resistant hydraulic fluid is required, special seals must be used. Contact Cascade.
- ② Flow less than recommended will result in slow fork positioning speed.
- ③ Flow greater than maximum can result in excessive heating, reduced system performance and reduced hydraulic system life.

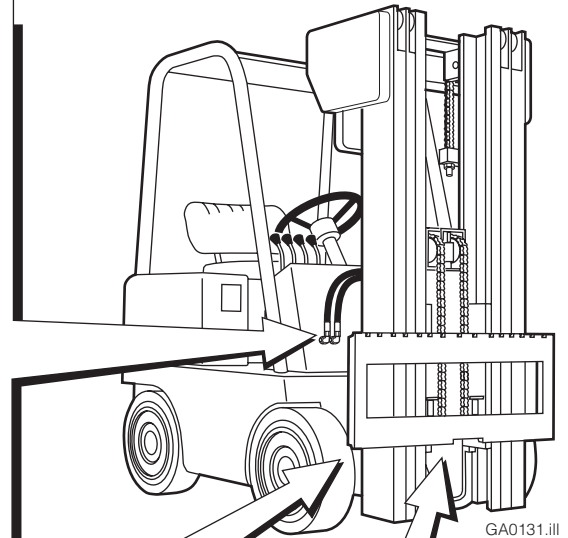

## Carriage Mount Dimension A-ISO

	Minimum	Maximum
<b>Class II</b>	380.0 mm	381.0 mm
<b>Class III</b>	474.5 mm	476.0 mm
<b>Class IV</b>	595.5 mm	597.0 mm

GA0028.ill

**Carriage** – Clean and inspect carriage bars. Bars must be parallel and ends flush. Grind smooth any protruding welds that may affect Sideshifter lower bearings. Repair any damaged notches.

## Auxiliary Valve Functions

Check for compliance with ISO standards:

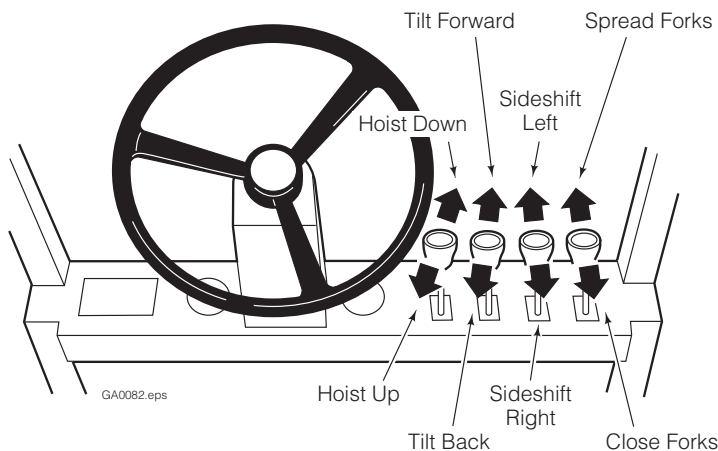

## Recommended Hydraulic Supply

**Fork Position function:** No. 6 hoses and fittings with 7 mm minimum I.D.

**Sideshift function:** No. 6 hoses and fittings with 7 mm minimum I.D.

Refer to *Cascade Hose & Cable Reel Selection Guide*, Part No. 212199 to select the correct hose reel for the mast and truck.

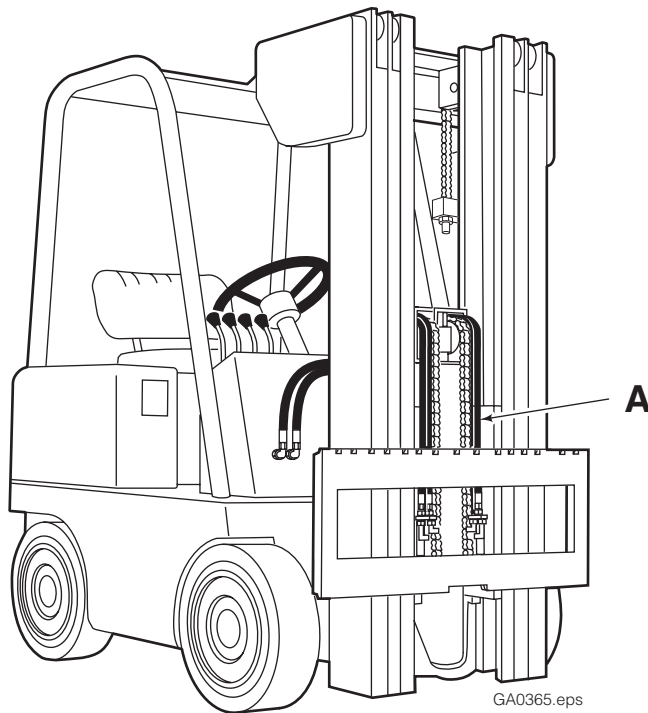

### **Fork Position**

**A** Mast Single Internal Reeving

### **Fork Position & Sideshift**

**A** Mast Double Internal Reeving

# INSTALLATION

## 1 Attach overhead hoist

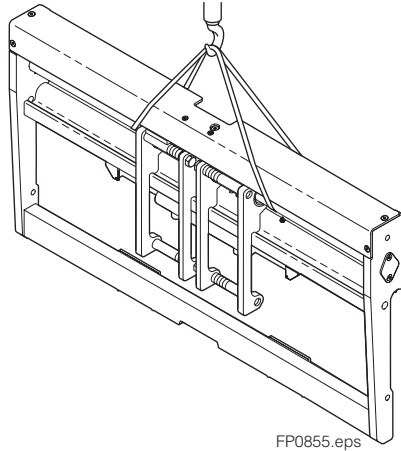

FP0855.eps

## 2 Remove lower hooks

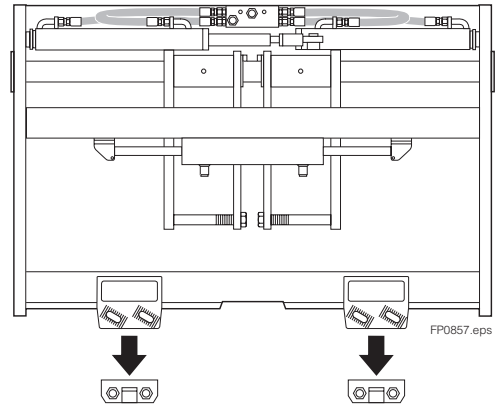

FP0857.eps

Back View



**WARNING:** Make sure overhead hoist has a rated capacity of at least 450 kg.

## 3 Mount on truck carriage

ITA Class II – 15-17 mm  
ITA Class III – 18-20 mm

ITA Class II – 8-9 mm  
ITA Class III – 10-11 mm

Engage locator tab with carriage center notch

Truck Upper Carriage Bar

GA0035.eps

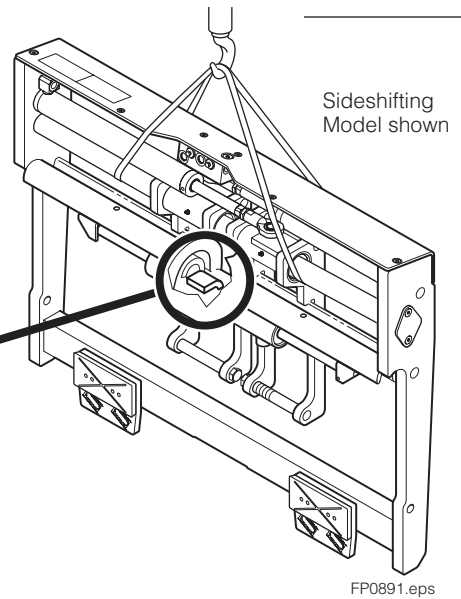

Sideshifting Model shown

FP0891.eps

## 4 Install lower hooks

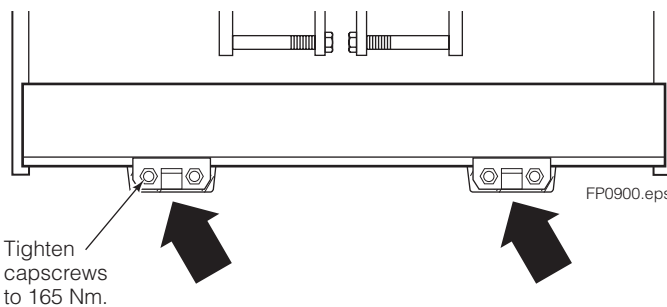

Tighten cap screws to 165 Nm.

FP0900.eps

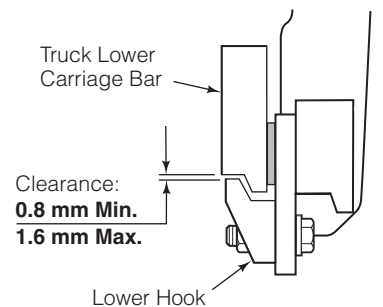

Truck Lower Carriage Bar

Clearance:  
**0.8 mm Min.**  
**1.6 mm Max.**

Lower Hook

## 5 Flush supply hoses

- A** Connect supply hoses to truck supply terminals and connect together using a union fitting as shown.
- B** Operate auxiliary valve for 30 sec.
- C** Remove union fitting.

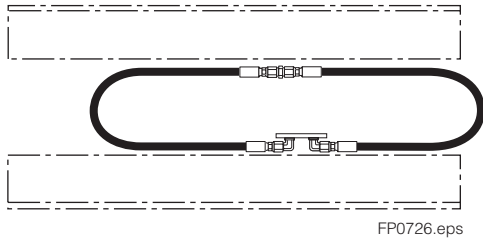

## 6 Install hoses

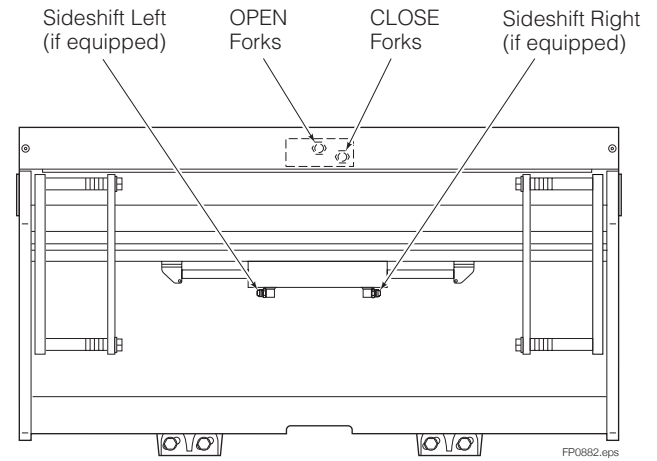

Front View

## 7 Install forks

- A** Remove capscrews and fork carrier inner retainers.
- B** Install forks using a pallet or blocks. Keep feet clear of forks.
- C** Reinstall fork carrier inner retainers and spacers. Tighten capscrews to 35 Nm.

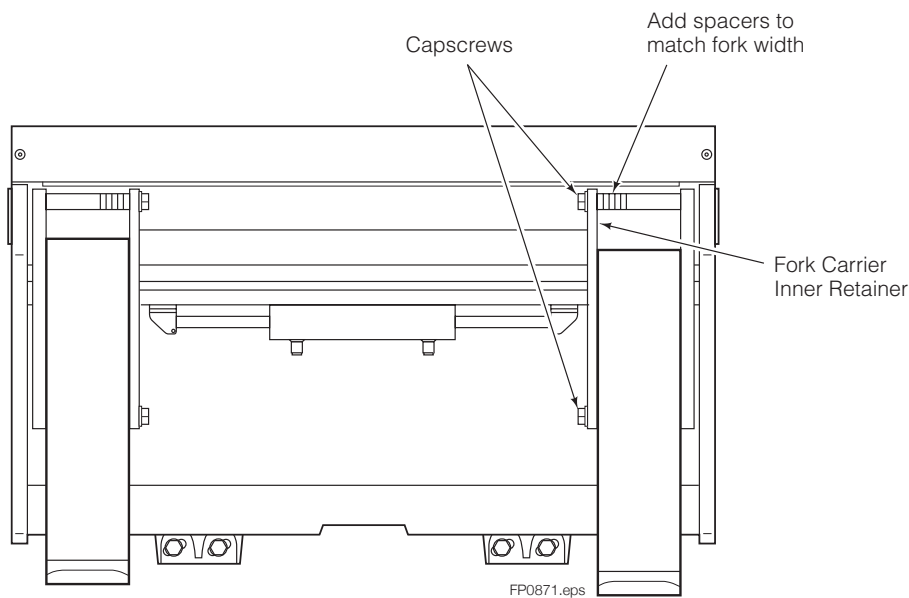
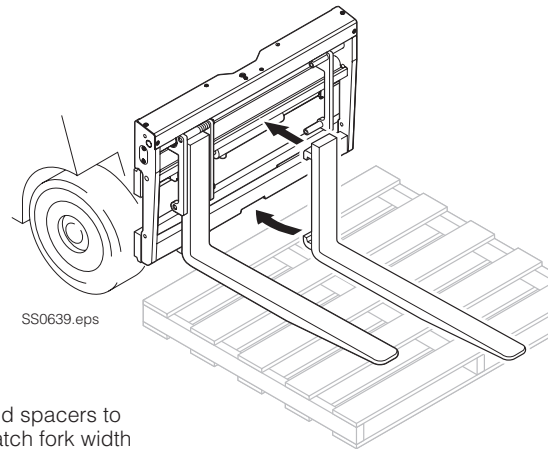



## 9 Lubrication

The Fork Positioner is prelubed at the factory and requires no lubrication for installation. Use graphite dry lube for fork bars as required ('Slip Plate Aerosol', 'GraphoKote' or equivalent).

Lubricate as described in the *Periodic Maintenance* section.

## 10 Cycle Fork Positioner functions

- Open and close forks several times. Sideshift (if equipped) left and right. Check for smoothness and equal movement.
- Check for operation in accordance with ISO standards.
- Check for leaks at fittings, valve, cylinders.

### AUXILIARY VALVE FUNCTIONS

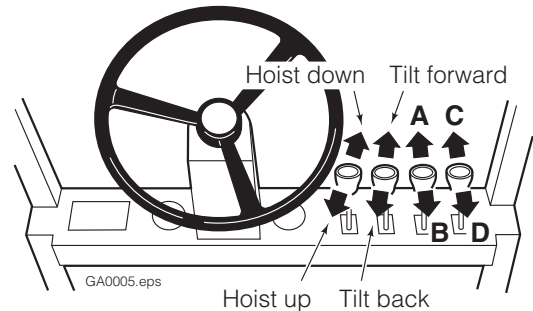

#### FORK POSITION

- A** Spread Forks
- B** Close Forks

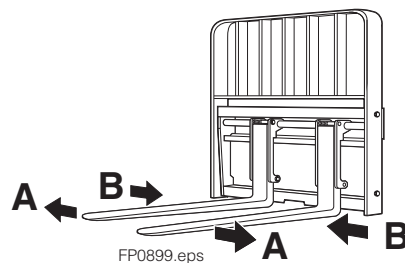

#### FORK POSITION & SIDESHIFT

- A** Sideshift Left
- B** Sideshift Right
- C** Spread Forks
- D** Close Forks

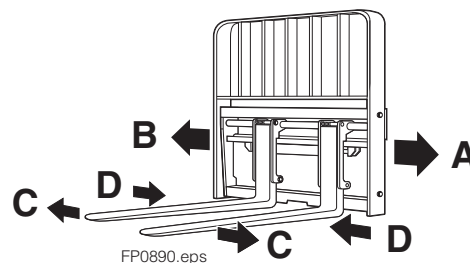

## 11 Adjust valve flow controls for equal fork movement (if required)

**NOTE:** Attachment is Factory-adjusted for equal fork movement when operated at recommended pressure and flow rate.

- A** Open forks fully, then close. Look for unequal fork movement and note which cylinder is faster.
- B** On faster fork (one that bottoms first), loosen jam nut and screw flow control in (CW) 1/2-turn.
- C** Repeat Step B until fork movement is equal. Tighten jam nut.

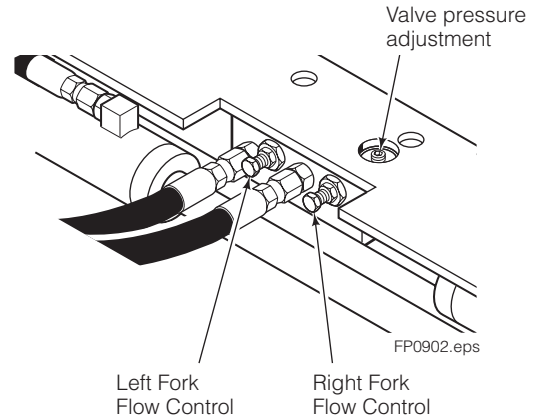

## 12 Inspect fork hooks and carriage bars

**NOTE:** Use Go/No-Go Wear Gauge part no. 209560 (Class II) or 209561 (Class III).

- A** Inspect the fork lower hooks and carriage bar. If the gauge fits between the carriage bar and lower hook, repair or replacement is needed.
- B** Inspect the upper carriage bar. If the gauge arrow touches the carriage bar, repair or replacement is needed.
- C** Inspect the fork upper hooks. If the gauge arrow touches the hook, repair or replacement is needed.

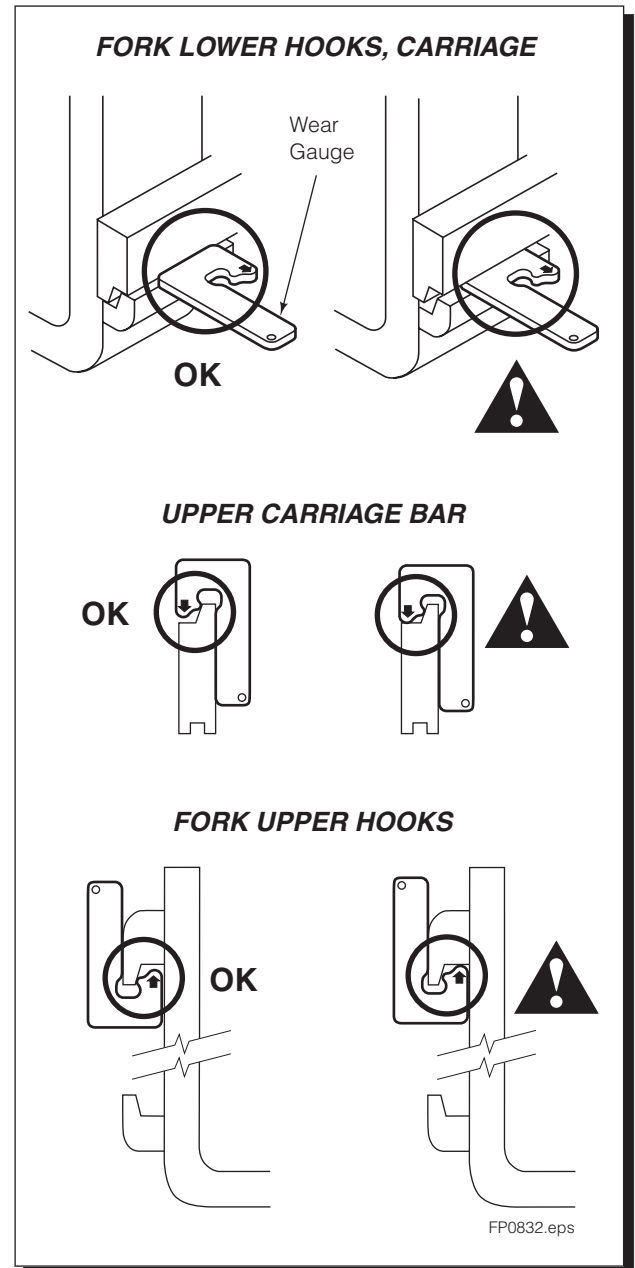



**WARNING:** After completing any service procedure, always test the Fork Positioner through five complete cycles to make sure the attachment operates correctly before returning it to the job.

## 100-Hour Maintenance

Every time the lift truck is serviced or every 100 hours of truck operation, whichever comes first, complete the following maintenance procedures:

- Check for loose or missing capscrews, worn or damaged hoses, and hydraulic leaks.
- Inspect lower hooks for wear and proper clearance. Adjust if necessary (see Installation, Step 4).
- If required, tighten fork carrier capscrews to 35 Nm.

## 300-Hour Maintenance

After each 300 hours of truck operation, in addition to the 100-hour maintenance, perform the following procedures:

- Tighten backrest capscrews (Cascade) to 195 Nm.
- Apply general-purpose lithium-based chassis grease to fork carrier bearing grease fittings.
- Apply graphite dry-lube to fork carriage bars as required ('Slip Plate Aerosol', 'GraphoKote' or equivalent).

## 1000-Hour Maintenance

After each 1000 hours of truck operation, in addition to the 100 and 300-hour maintenance, perform the following procedures:

- Inspect fork carriers for looseness on shaft, and cylinder rod anchors for excessive end play (see Service Manual for repair procedures).
- Inspect upper and lower bearings for wear. If any bearing is worn to less than 2.5 mm thickness, replace the entire bearing set (see Service Manual for repair procedures).
- Inspect forks and carriage bars for wear.

**NOTE:** Cascade fork safety kit 3014162 available with wear calipers, inspection sheets and safety poster. Also available Cascade fork hook & carriage bar wear gauge 209560 (CL II) and 209561 (CL III).

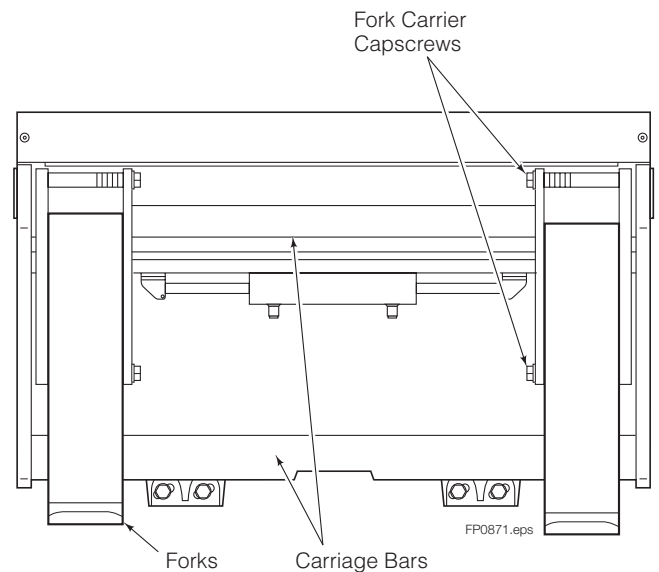

Front View

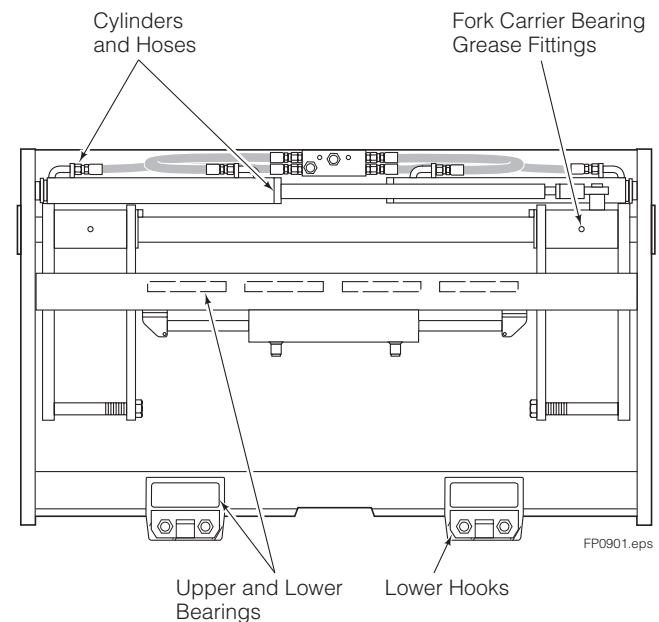

Back View

**Do you have questions you need answered right now?** Call your nearest Cascade Service Department. Visit us online at [www.cascorp.com](http://www.cascorp.com)

### **AMERICAS**

**Cascade Corporation  
Parts Sales**  
2501 Sheridan Ave.  
Springfield, OH 45505  
Tel: 888-CASCADE (227-2233)  
Fax: 888-329-0234

**Cascade Canada Inc.**  
5570 Timberlea Blvd.  
Mississauga, Ontario  
Canada L4W-4M6  
Tel: 905-629-7777  
Fax: 905-629-7785

**Cascade do Brasil**  
Rua João Guerra, 134  
Macuco, Santos - SP  
Brasil 11015-130  
Tel: 55-13-2105-8800  
Fax: 55-13-2105-8899

### **EUROPE-AFRICA**

**Cascade Italia S.R.L.  
European Headquarters**  
Via Dell'Artigianato 1  
37050 Vago di Lavagno (VR)  
Italy  
Tel: 39-045-8989111  
Fax: 39-045-8989160

**Cascade (Africa) Pty. Ltd.**  
PO Box 625, Isando 1600  
60A Steel Road  
Sparton, Kempton Park  
South Africa  
Tel: 27-11-975-9240  
Fax: 27-11-394-1147

### **ASIA-PACIFIC**

**Cascade Japan Ltd.**  
2-23, 2-Chome,  
Kukuchi Nishimachi  
Amagasaki, Hyogo  
Japan, 661-0978  
Tel: 81-6-6420-9771  
Fax: 81-6-6420-9777

**Cascade Korea**  
121B 9L Namdong Ind.  
Complex, 691-8 Gojan-Dong  
Namdong-Ku  
Inchon, Korea  
Tel: +82-32-821-2051  
Fax: +82-32-821-2055

**Cascade-Xiamen**  
No. 668 Yangguang Rd.  
Xinyang Industrial Zone  
Haicang, Xiamen City  
Fujian Province  
P.R. China 361026  
Tel: 86-592-651-2500  
Fax: 86-592-651-2571

**Cascade India Material  
Handling Private Limited**  
No 34, Global Trade Centre  
1/1 Rambaugh Colony  
Lal Bahadur Shastri Road,  
Navi Peth, Pune 411 030  
(Maharashtra) India  
Phone: +91 020 2432 5490  
Fax: +91 020 2433 0881

**Cascade Australia Pty. Ltd.**  
1445 Ipswich Road  
Rocklea, QLD 4107  
Australia  
Tel: 1-800-227-223  
Fax: +61 7 3373-7333

**Cascade New Zealand**  
15 Ra Ora Drive  
East Tamaki, Auckland  
New Zealand  
Tel: +64-9-273-9136  
Fax: +64-9-273-9137

**Sunstream Industries  
Pte. Ltd.**  
18 Tuas South Street 5  
Singapore 637796  
Tel: +65-6795-7555  
Fax: +65-6863-1368

