



# Technical Bulletin

## Char-Lynn Drive Motor Conversion Kits 675343 and 675344 Installation Instructions

This sheet provides instructions for the installation of Char-Lynn Drive Motor Service Kits part no. 675343 (3.0 cu.in.) and 675344 (4.5 cu.in.) to D-Series rotating attachments. The kits include a Drive Motor, 2 O-rings, 1 Shim, 1 Gasket and sealant.

1. Rotate the attachment to position the arms or forks in the normal loading position. Position the forks or arms to the width of the frame.
2. Remove the lower mounting hooks. For reassembly, tighten the lower mounting hook capscrews to a torque of:  
**ITA II - 105-115 ft.-lbs.**  
**ITA III - 180-200 ft.-lbs.**  
**ITA IV - 180-200 ft.-lbs.**



**WARNING:** Before removing any hoses, relieve pressure in the hydraulic system. Turn the truck ignition off, then actuate the truck auxiliary control valves several times in both directions.

3. Disconnect and plug the hydraulic hoses to the attachment. Tag the hoses for reassembly.
4. Roll Clamps and Revolving Clamps
  - Set the attachment on a pallet. Tilt the mast forward and back away.

#### Rotators

- Attach an overhead hoist (3200 lbs. min.) to the upper fork bar. Tilt the mast forward. Remove the attachment and place on a pallet.
5. Remove the four capscrews fastening the drive group to the baseplate. For reassembly, tighten the capscrews to a torque of 65-75 ft.-lbs.
  6. Remove end cover fill hole plug. Drain oil from drive group.

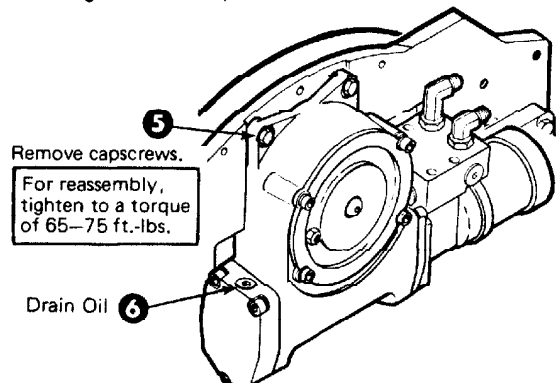
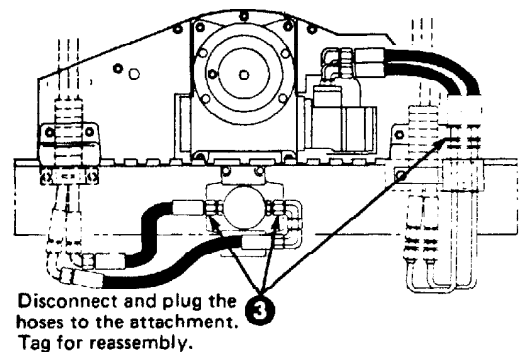
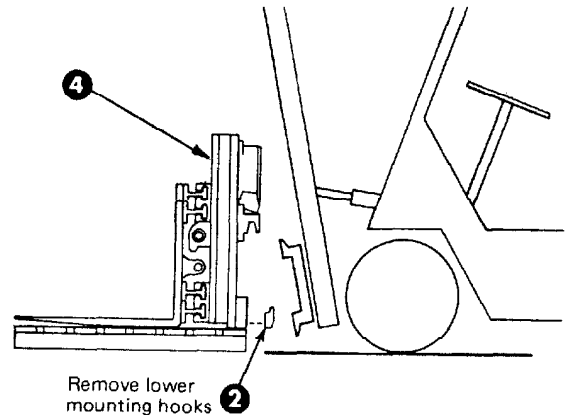

**cascade<sup>®</sup> corporation**

For Technical Assistance . . .

Call 1-800-CASCADE or 503-666-1518

OR

Write: Cascade Corporation, P.O. Box 20187, Portland, OR 97220

To Order Parts . . .

Call 1-800-221-1447

OR

Write: Cascade Corporation, P.O. Box 360 Springfield, OH 45505

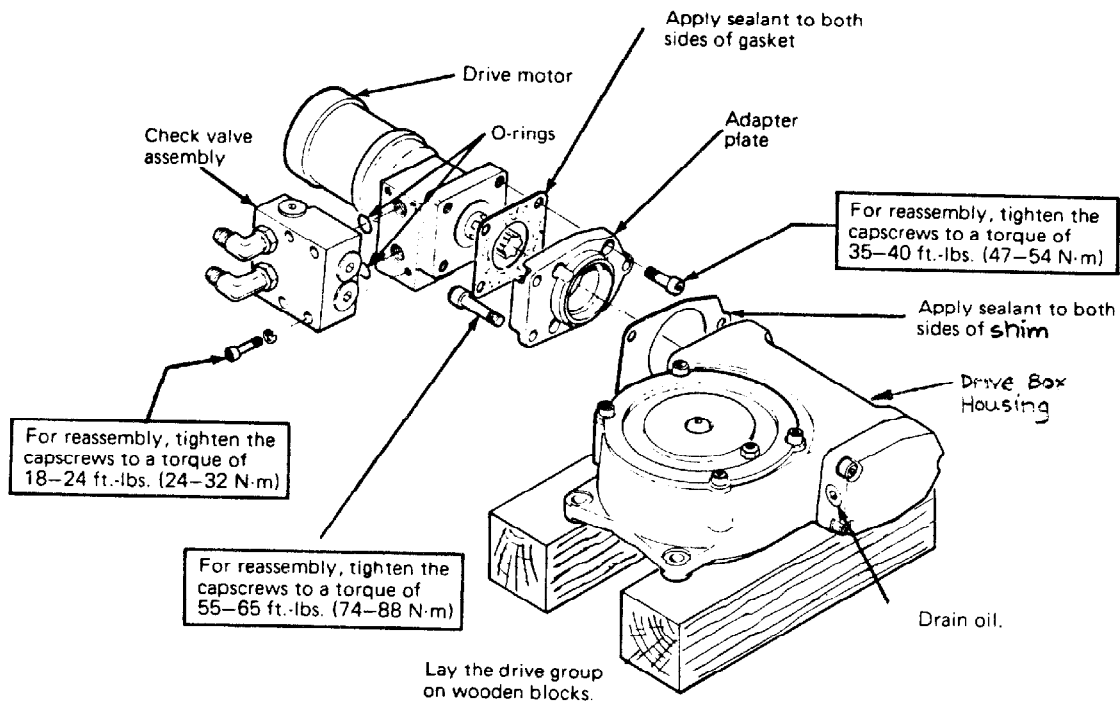

7. Lay the drive group (pinion down) on wooden blocks placed on both sides of the pinion.
8. Remove the four capscrews fastening the check valve assembly to drive motor. Note the location of the two O-rings between the check valve assembly and drive motor for reassembly.
9. Remove the three capscrews fastening the adapter plate/drive motor to the drive box housing. Tap the drive motor with a rubber mallet to break the adapter plate loose from the drive box housing.
10. Remove and discard the old adapter plate/drive box housing shim. Remove the adapter plate and gasket from the drive motor.
11. Clean the adapter plate, drive motor and drive box housing gasket surfaces.

## Reassembly

1. Apply sealant to both sides of the new adapter plate/drive motor gasket. Apply sealant to the threads of the four drive motor capscrews. Install the gasket and adapter plate to the drive motor. Tighten the capscrews to torque of 35-40 ft.-lbs.
2. Apply sealant to both sides of the new adapter plate/drive box housing shim. Apply sealant to the threads of the three adapter plate capscrews. Install the adapter plate/drive motor and shim to the drive box housing. Tighten the capscrews to a torque of 55-65 ft.-lbs.
3. Fill the housing through the end cover fill hole with 2-1/2 cups (600ML) Cascade Gear Lube part no. 656300 or equivalent SAE 90 wt. lube (AGMA "mild" 6EP Gear Oil).
4. Further reassembly is a reverse of disassembly except as follows:
  - After the drive group has been reinstalled, check the oil level in the drive assembly. The oil level must be visible in the fill hole. Fill if necessary with Cascade Gear Lube part no. 656300.
  - **IMPORTANT:** The Char-Lynn drive motor rotates in the reverse direction of the Ross drive motor. The hydraulic supply hoses to the drive motor must be reversed when installed.