

USER MANUAL

K-Series

Integral Fork Positioner & Sideshifter

Manual Number 6054520-R6

**cascade[®]
corporation**

Cascade is a Registered Trademark of Cascade Corporation

C ONTENTS

	Page
INTRODUCTION	
Special Definitions	1
OPERATION	
Safety Rules	2
Industrial Lift Trucks	2
Handling Loads	3
Fork Positioner/Sideshifter Operation	3
Daily Inspection	4
Safe Operation and Maintenance	5
OSHA Regulations	5
INSTALLATION	
Truck Requirements	6
Recommended Hydraulic Supply	6
Attachment Installation	7
PERIODIC MAINTENANCE	
100-Hour Maintenance	13
300-Hour Maintenance	13
1000-Hour Maintenance	13
2000-Hour Maintenance	14
PARTS	
Recommended Spare Parts	15
Publications	15
Contacting Cascade	back cover

I NTRODUCTION

This manual is for the Cascade K-Series Integral Fork Positioner & Sideshifter. Contents include an Operator's Guide, Installation Instructions, Periodic Maintenance and Recommended Spare Parts.

IMPORTANT: K-Series Integral Fork Positioner & Sideshifter is metric. Supply fittings adapted as required for application.

NOTE: All specifications are shown in U.S. and (Metric) units where applicable. All fasteners have a torque value range of $\pm 10\%$ of stated value.

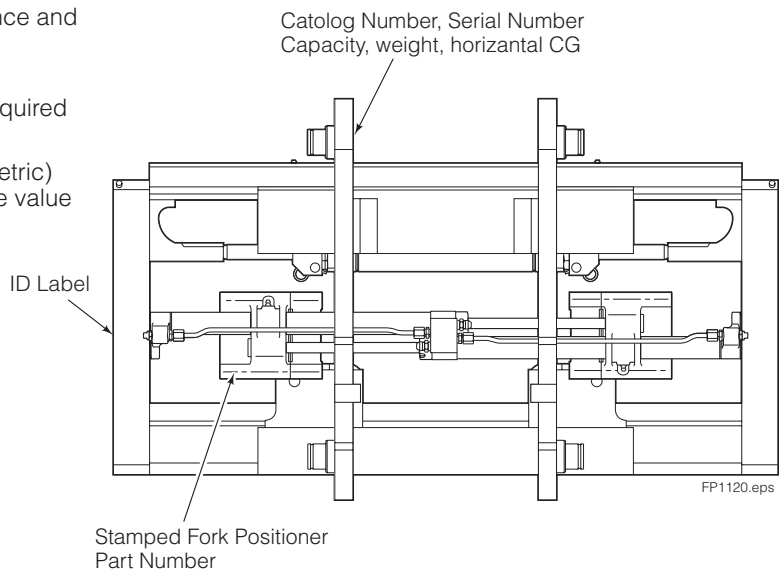

Back (Driver's) View

Special Definitions

The statements shown appear throughout this Manual where special emphasis is required. Read all WARNINGS and CAUTIONS before proceeding with any work. Statements labeled IMPORTANT and NOTE are provided as additional information of special significance or to make the job easier.



WARNING – A statement preceded by WARNING is information that should be acted upon to prevent bodily injury. A WARNING is always inside a ruled box.

CAUTION – A statement preceded by CAUTION is information that should be acted upon to prevent machine damage.

IMPORTANT – A statement preceded by IMPORTANT is information that possesses special significance.

NOTE – A statement preceded by NOTE is information that is handy to know and may make the job easier.



WARNING: Rated capacity of the truck/attachment combination is a responsibility of the original truck manufacturer and may be less than shown on the attachment nameplate. Consult the truck nameplate.

WARNING: Do not operate this attachment unless you are a trained and authorized lift truck driver.

WARNING: Usable fork length must not exceed 60 in. (1500 mm).

OPERATION

This section contains operating instructions for the Cascade K-Series Integral Fork Positioner & Sideshifter. It will help you avoid common errors which often cause damage to the equipment or product being handled.

This information is intended to simplify operator understanding about effective and safe Fork Positioner & Sideshifter use and operation. Read this information thoroughly before operating the attachment. Be sure you know and understand all operating procedures and safety precautions. If you have any questions or don't understand a procedure, ask your supervisor.

Emphasize Safety! Most accidents are caused by operator carelessness or misjudgment. You must watch for poorly maintained equipment and hazardous situations and correct them.

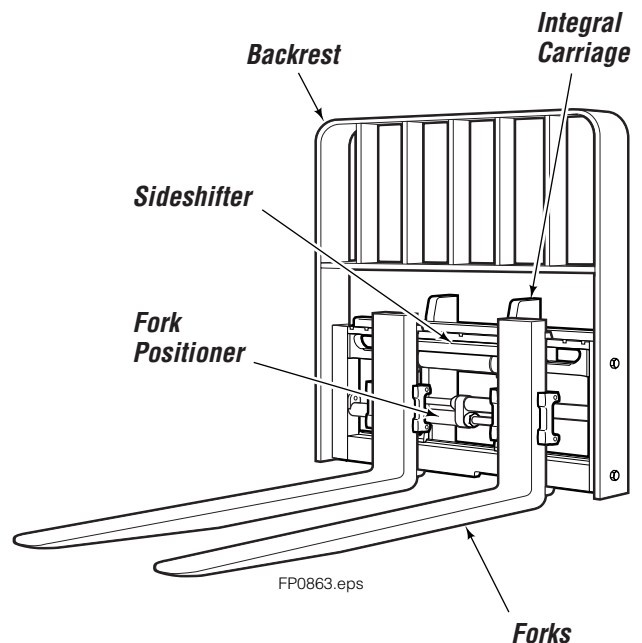

OPERATION

Safety Rules – Industrial Lift Trucks

No riders



No reaching through mast



No standing under load



GA0047.eps

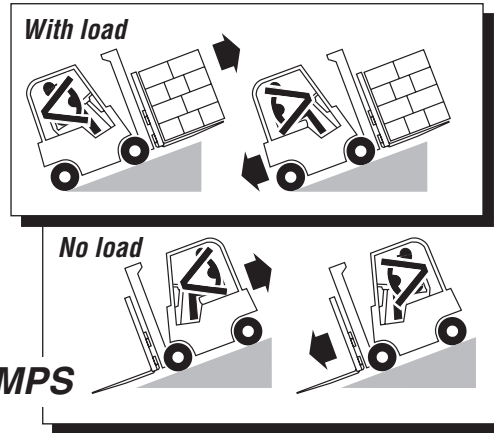
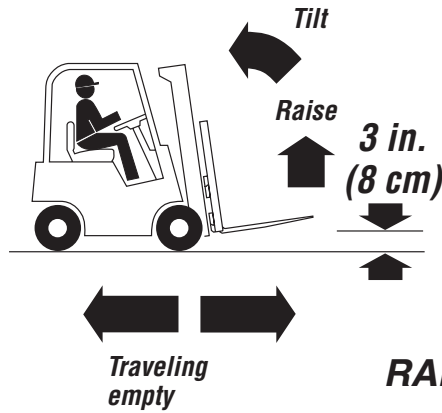

No parking on ramp



No turning on ramp

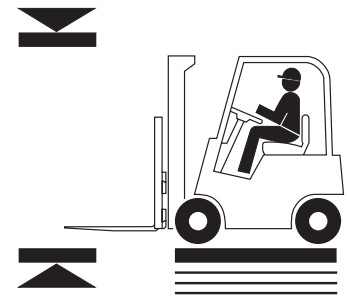

Watch clearances

GA0048.eps

<p>TRAFFIC</p> <p>Observe</p> <p>Wet floors</p>			<p>Workers</p>	<p>Stops</p>	<p>Slow for two-way traffic</p>	<p>Sound horn, slow at intersection</p>	<p>Sound horn, slow at corner</p>
	<p>Bumps</p>	<p>Dips</p>					

OPERATION

Safety Rules – Handling Loads

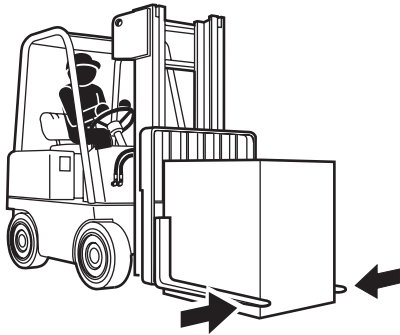

CAUTION: Do not put side loads on forks.

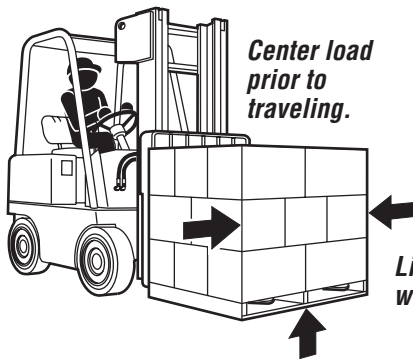

Center load prior to traveling.

Raise load prior to sideshifting.

Limit sideshifting with raised load.

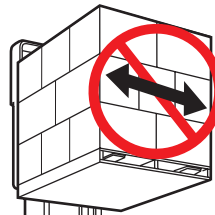

Limit truck movement with raised load.

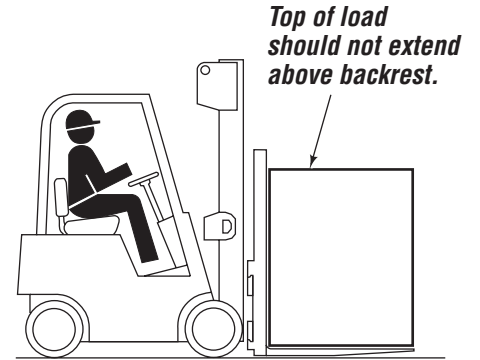

Top of load should not extend above backrest.

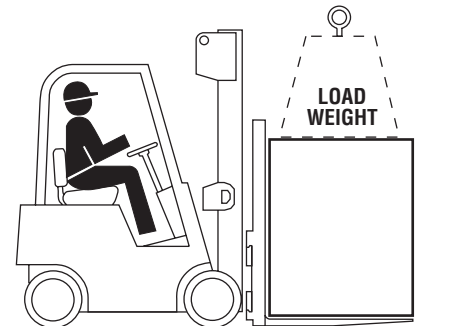

FP0174.eps

Load weight must not exceed combined truck/attachment capacity (see truck nameplate).

Total fork capacity (LH + RH fork) must be greater than load weight. Check capacity stamp on forks.

Fork Positioner & Sideshifter Operation

AUXILIARY VALVE FUNCTIONS

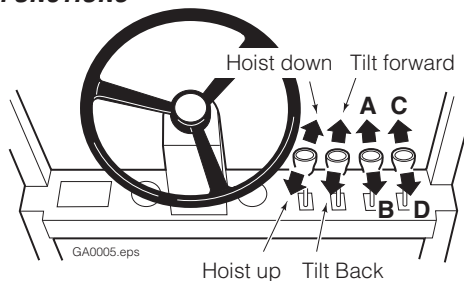

GA0005.eps



WARNING: Truck control handle and attachment function activation shown here conforms to ASME/ANSI B56.1 recommended practices. Failure to follow these practices may lead to serious bodily injury or property damage. End user, dealer and OEMs should review any deviation from the practices for safe operation.

SIDESHIFTING & FORK POSITIONING

- A Sideshift Left
- B Sideshift Right
- C Open/Spread Forks
- D Close forks

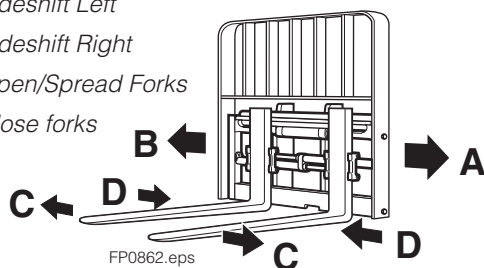

FP0862.eps

SIDESHIFTING & FORK POSITIONING WITH SOLENOID VALVE

- A Sideshift Left
- A Open/Spread Forks (press knob button)
- B Sideshift Right
- B Close Forks (press knob button)

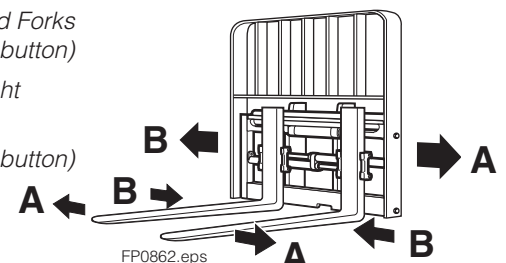

FP0862.eps

OPERATION

Daily Inspection

Check items shown each day. Report problems to your supervisor. Refer to the attachment's service manual for troubleshooting and repair procedures.

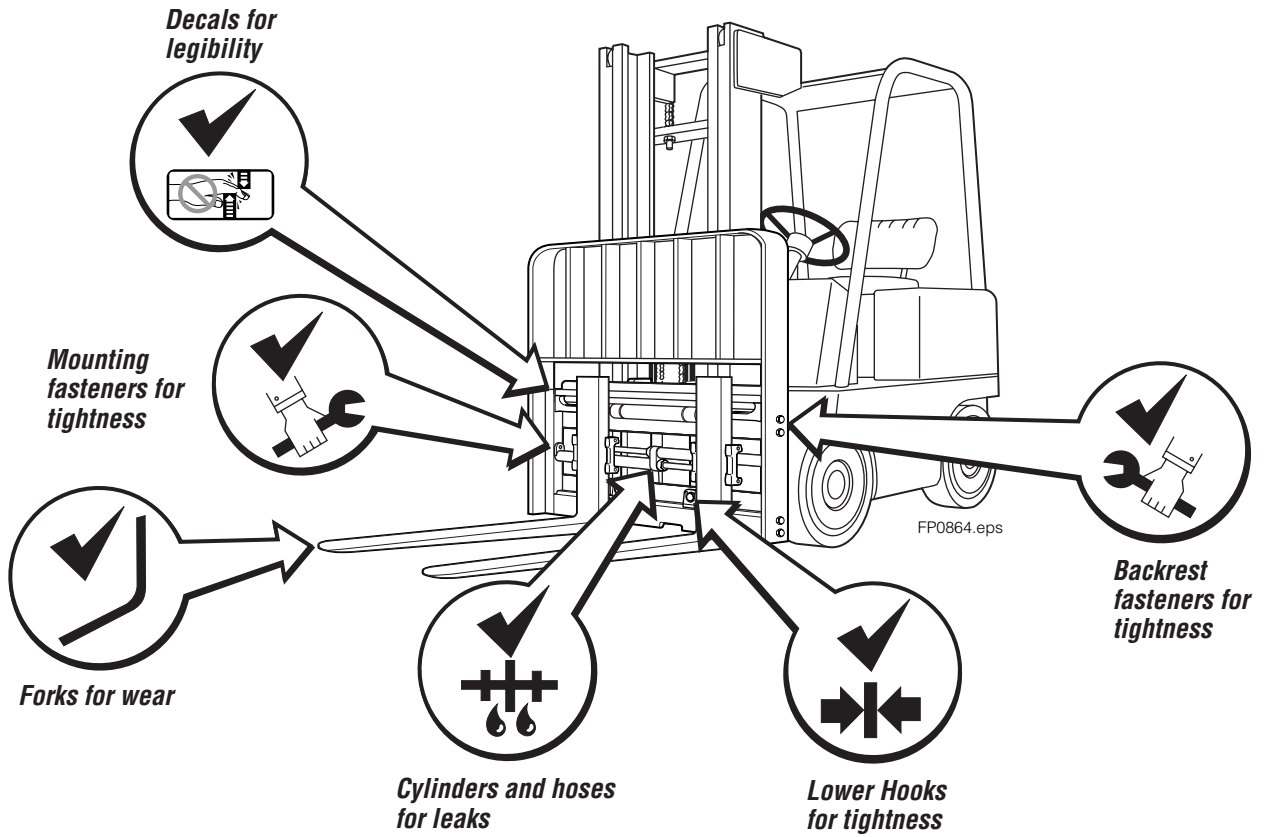



SAFE OPERATION AND MAINTENANCE

OSHA Regulations – Trucks and Attachments (Specific Regulations from OSHA 1910.178)



WARNING: The safe operation and maintenance of industrial trucks is regulated by Occupational Safety and Health (OSHA) regulations 1910.178 and American National Standards Institute (ANSI) Safety Standard for Powered Industrial Trucks, ANSI B56.1. When operating and maintaining industrial trucks equipped with attachments you should pay particular attention to the following sections of these regulations. You should be familiar with **all** sections of these regulations. **Ask your employer for the complete regulations.**

(a) General Requirement

- (4) Modifications and additions which affect capacity and safe operation shall not be performed by the customer or user without manufacturers prior written approval. Capacity, operation and maintenance instruction plates, tags or decals shall be changed accordingly.
- (5) If the truck is equipped with front-end attachments other than factory installed attachments, the user shall request that the truck be marked to identify the attachments and show the appropriate weight of the truck and attachment combination at maximum elevation with load laterally centered.
- (6) The user shall see that all nameplates and markings are in place and maintained in a legible condition.

(e) Safety Guards

- (2) If the type of load presents a hazard, the user shall equip fork trucks with a vertical load backrest extension in accordance with (a)(2) following.

(a)(2) All new powered industrial trucks acquired and used by an employer after February 15, 1972 shall meet the design and construction requirements for powered industrial trucks established in the "American National Standard for Powered Industrial Trucks, Part II, ANSI B56.1", except for vehicles intended primarily for earth moving or over-the-road hauling.

(l) Operator Training

Only trained and authorized operators shall be permitted to operate a powered industrial truck. Methods shall be devised to train operators in the safe operation of powered industrial trucks.

(m) Truck Operations

- (1) Trucks shall not be driven up to anyone standing in front of a bench or other fixed object.
- (2) No person shall be allowed to stand or pass under the elevated portion of any truck, whether loaded or empty.
- (3) Unauthorized personnel shall not be permitted to ride on powered industrial trucks. A safe place to ride shall be provided where riding of trucks is authorized.
- (4) The employer shall prohibit arms or legs from being placed between the uprights of the mast or outside the running lines of the truck.
- (5i) When a powered industrial truck is left unattended, load engaging means shall be fully lowered, controls shall be neutralized, power shall be shut off and brakes set. Wheels shall be blocked if the truck is parked on an incline.
- (5ii) A powered industrial truck is unattended when the operator is 25 feet or more away from the vehicle which remains in his view, or whenever the operator leaves the vehicle and it is not in his view.
- (5iii) When the operator of an industrial truck is dismounted and within 25 feet of the truck still in his view, the load engaging means shall be fully lowered, controls neutralized and the brakes set to prevent movement.
- (6) A safe distance shall be maintained from the edge of ramps or platforms while on any elevated dock or platform or freight car. Trucks shall not be used for opening or closing freight doors.

- (10) A load backrest extension shall be used whenever necessary to minimize the possibility of the load or part of it from falling rearward.

(n) Traveling

- (4) The driver shall be required to slow down and sound the horn at cross isles and other locations where vision is obstructed. If the load being carried obstructs forward view, the driver shall be required to travel with the load trailing.
- (7i) When ascending or descending grades in excess of 10 percent, loaded trucks shall be driven with the load upgrade.
- (7iii) On all grades the load and load engaging means shall be tilted back if applicable, and raised only as far as necessary to clear the road surface.

(o) Loading

- (1) Only stable or safely arranged loads shall be handled. Caution shall be exercised when handling off-center loads which cannot be centered.
- (2) Only loads within the rated capacity of the truck shall be handled.
- (3) The long or high (including multiple-tiered) loads which may affect capacity shall be adjusted.
- (4) Trucks equipped with attachments shall be operated as partially loaded trucks when not handling a load.
- (5) A load engaging means shall be placed under the load as far as possible; the mast shall be carefully tilted backward to stabilize the load.
- (6) Extreme care shall be used when tilting the load forward or backward, particularly when high tiering. Tilting forward with load engaging means elevated shall be prohibited except to pick up a load. An elevated load shall not be tilted forward except when the load is in a deposit position over a rack or stack. When stacking or tiering, only enough backward tilt to stabilize the load shall be used.

(p) Operation of the Truck

- (1) If at any time a powered industrial truck is found to be in need of repair, defective, or in any way unsafe, the truck shall be taken out of service until it has been restored to safe operating condition.

(q) Maintenance of Industrial Trucks

- (1) Any power-operated industrial truck not in safe operating condition shall be removed from service. All repairs shall be made by authorized personnel.
- (5) All parts of any such industrial truck requiring replacement shall be replaced only by parts equivalent as to safety with those used in the original design.
- (6) Industrial trucks shall not be altered so that the relative positions of the various parts are different from what they were when originally received from the manufacturer, nor shall they be altered either by the addition of extra parts not provided by the manufacturer or by the elimination of any parts. Additional counter-weighting of fork trucks shall not be done unless approved by the truck manufacturer.
- (7) Industrial trucks shall be examined before being placed in service and shall not be placed in service if the examination shows any condition adversely affecting the safety of the vehicle. Such examinations shall be made at least daily. When industrial trucks are used on a round-the-clock basis, they shall be examined after each shift. Defects when found shall be immediately reported and corrected.

INSTALLATION

Truck Requirements

Truck Relief Setting

2200 psi (152 bar) Recommended
3500 psi (241 bar) Maximum

Truck Flow Volume ^①

	Min. ^②	Recommended	Max. ^③
35K, 55K	1 GPM	2 GPM	3 GPM
70K	(4 L/min.)	(7.5 L/min.)	(12 L/min.)

① Cascade K-Series Integral Fork Positioner/Sideshifters are compatible with SAE 10W petroleum base hydraulic fluid meeting Mil. Spec. MIL-0-5606 or MIL-0-2104B. Use of synthetic or aqueous base hydraulic fluid is not recommended. If fire resistant hydraulic fluid is required, special seals must be used. Contact Cascade.

② Flow less than recommended will result in slow fork positioning speed.

③ Flow greater than maximum can result in excessive heating, reduced system performance and short hydraulic system life.

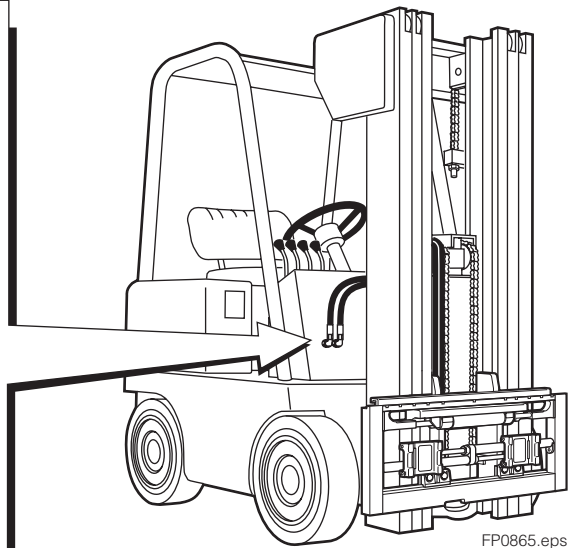

Auxiliary Valve Functions

Check for compliance with ITA (ISO) standards:

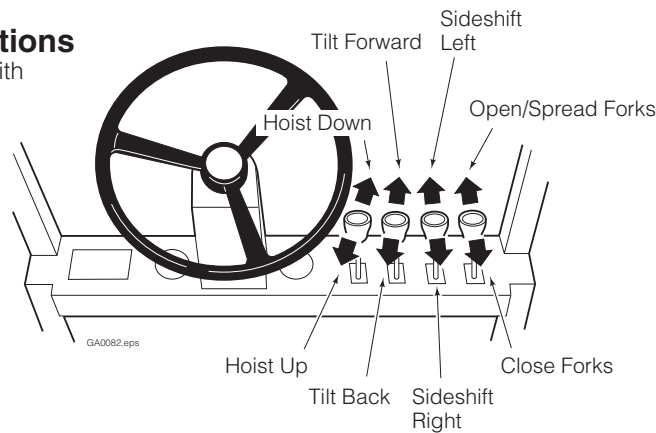

Recommended Hydraulic Supply

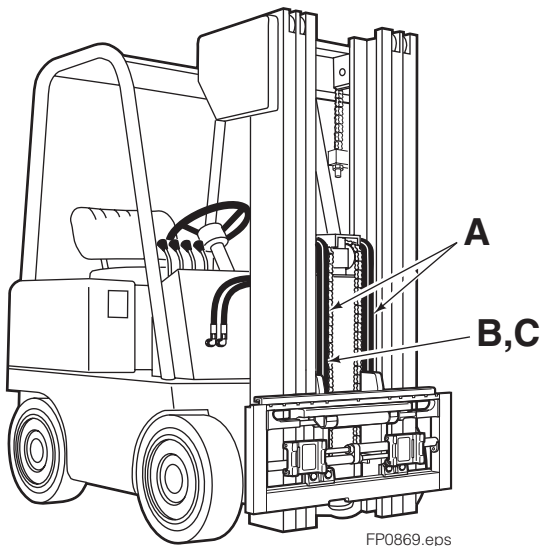

Fork Positioning function: No. 3 hose/No. 4 fittings with 5/32-in (4 mm) minimum I.D.

Sideshifting function: No. 4 hose/No. 6 fittings with 3/16-in. (5 mm) minimum I.D.

Refer to Cascade *Hose & Cable Reel Selection Guide*, Part No. 212199 to select the correct hose reel for the mast and truck.

Fork Positioning / Sideshifting

- A Mast Double Internal Reaving
- OR
- B Mast Single Internal Reaving with RF Hydraulic Control
- OR
- C Mast Single Internal Reaving with electrical cable and attachment mounted solenoid valve

INSTALLATION

Attachment Installation

IMPORTANT: Integral attachment installation is an OEM or dealer responsibility. Some of the following steps may or may not be required, but are shown for reference. Refer to the appropriate service manual for service and repair procedures.



WARNING: Check the attachment weight (located on the nameplate) to make sure the overhead hoist and chains or straps are at least the rated capacity of the attachment.

- 1** Integral Sideshifter carriage should be installed in mast per OEM specifications and procedures.

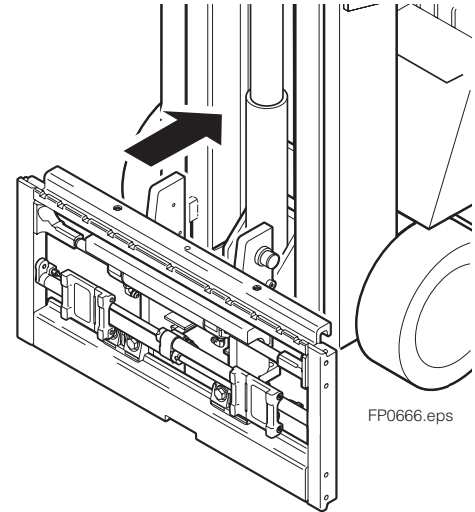

- 2** Check lower hook clearance

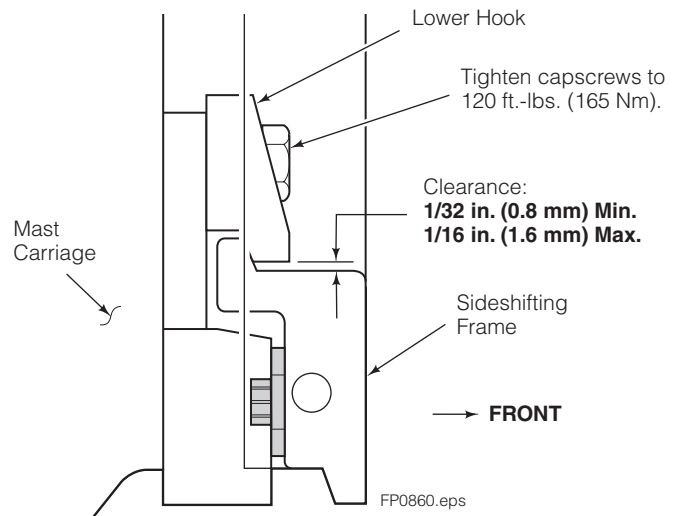
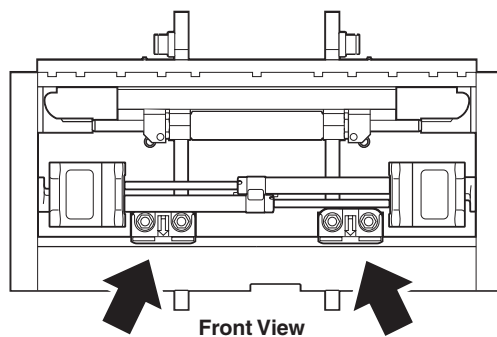

INSTALLATION

NOTE: Some configurations of this product are shipped with the fork positioner unmounted. Follow this step to install the mounting shims and capscrews.

3 Install Shims and Capscrews

- A** Shim as necessary with a maximum of 4 shims per side.
- B** Install capscrews and tighten to 50 ft.-lbs. (65 Nm).

NOTE: Maximum 4 shims per side. Maximum difference in number of shims per side is 2.

CAUTION: Total allowable gap before tightening capscrews is .020 in. (0.5 mm) maximum.

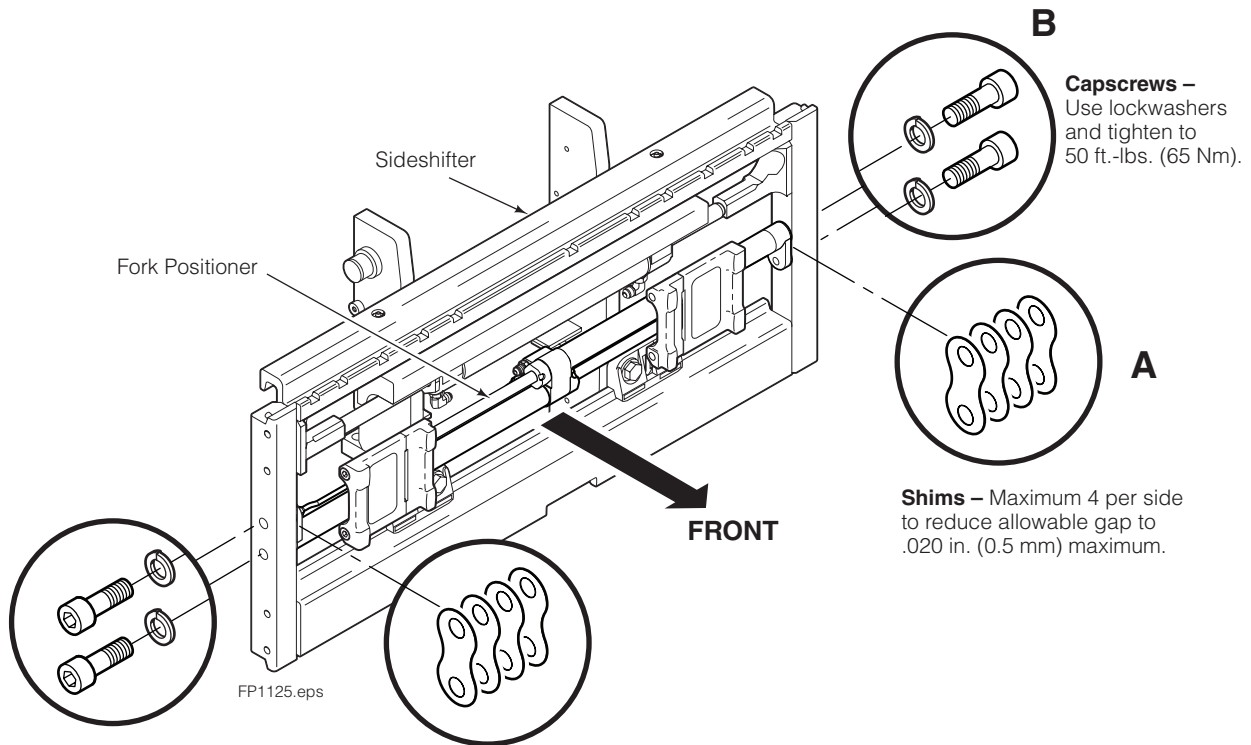

Recommended Torque Sequence

- A** LH side top
- B** RH side bottom
- C** RH side top
- D** LH side bottom

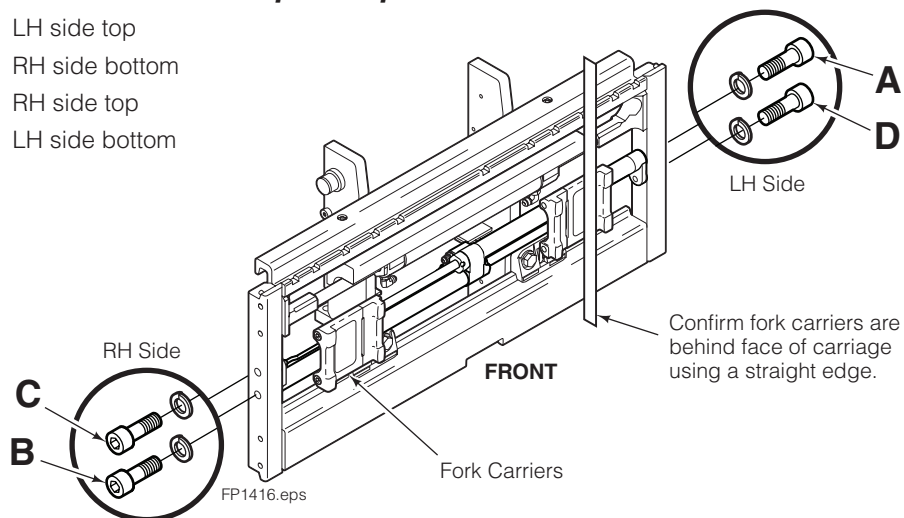

INSTALLATION

4 Flush supply hoses

- A** Connect supply hoses to supply terminals and connect together using union fittings as shown.
- B** Operate auxiliary valves for 30 sec.
- C** Remove union fittings.

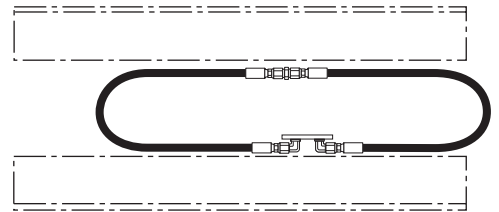

FP0726.eps

5 Install hoses

CAUTION: Allow for 4 inches sideshifting movement in each direction ('rolling' hose arrangement recommended).

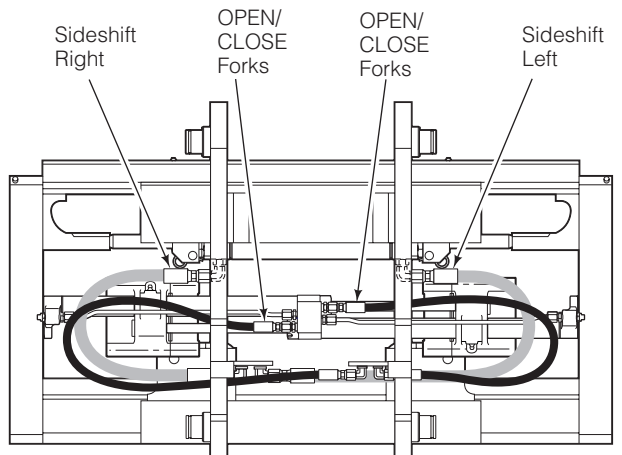

Back (Driver's View)

FP0858.eps

6 Remove fork locking pins

WARNING: Remove locking pins from forks. Make sure that forks slide freely on carriage bars.

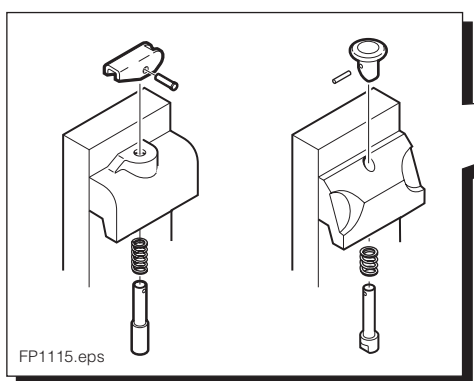

FP1115.eps

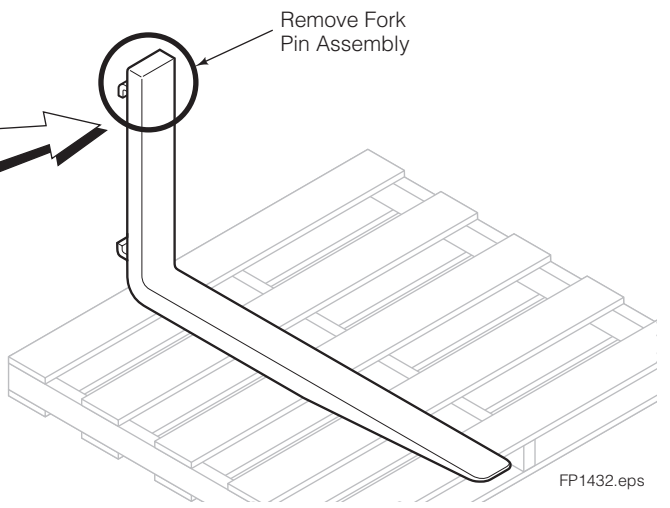

FP1432.eps

7 Install forks

- A** Remove capscrews from outer retainer section to remove inner retainer section.
- B** Install forks using a pallet or blocks. Keep feet clear of forks.
- C** Reinstall fork carrier inner retainer section and tighten capscrews to 25 ft.-lbs. (35 Nm).

NOTE: See illustration below to position inner retainers for various fork widths.



WARNING: Usable fork length must not exceed 60 in. (1500 mm).

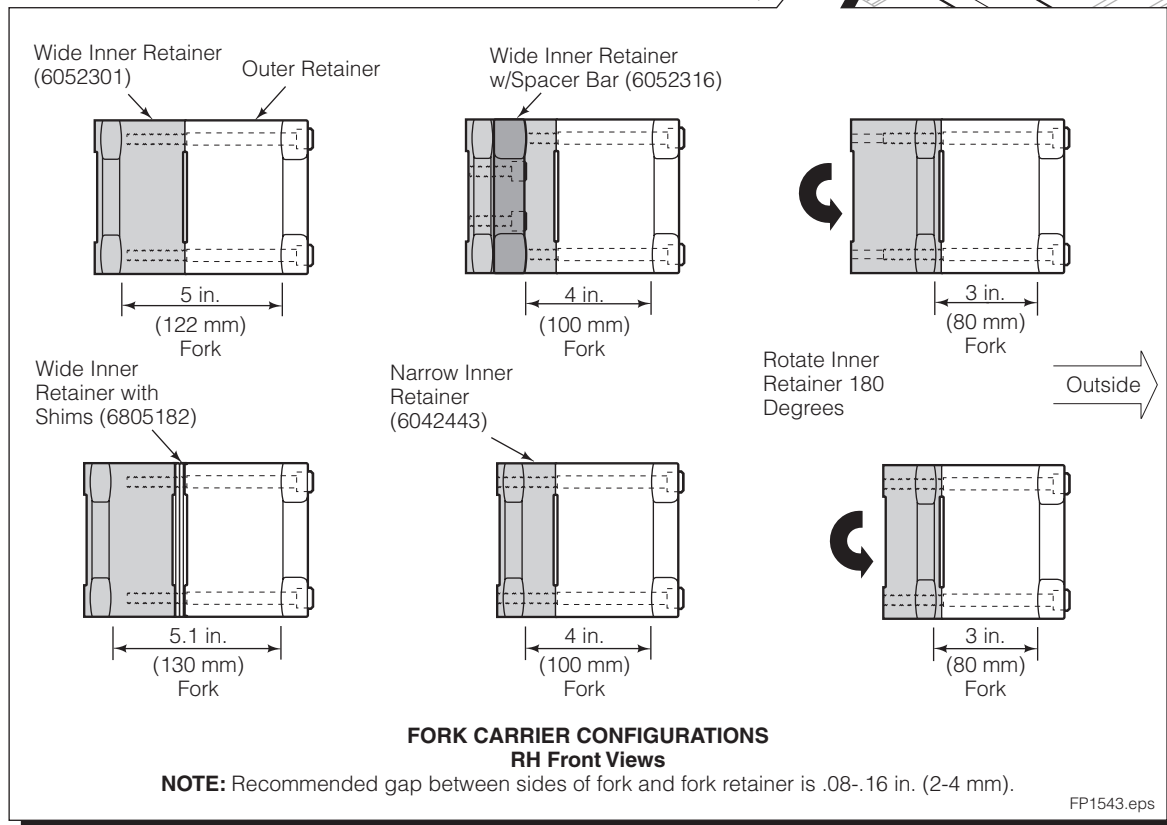
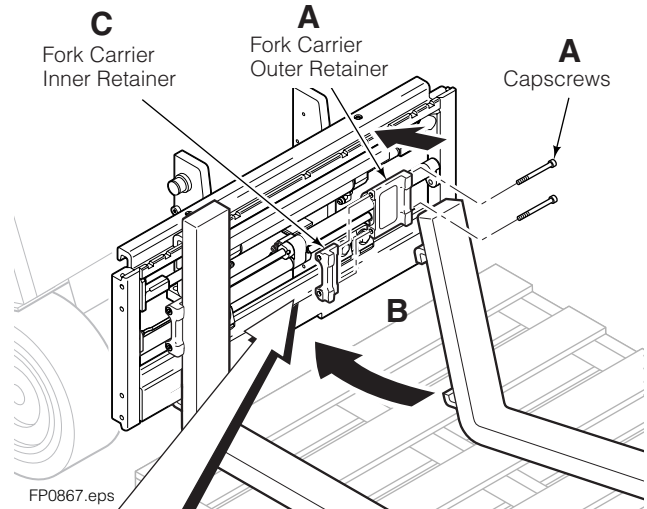

8 Install backrest (if applicable)

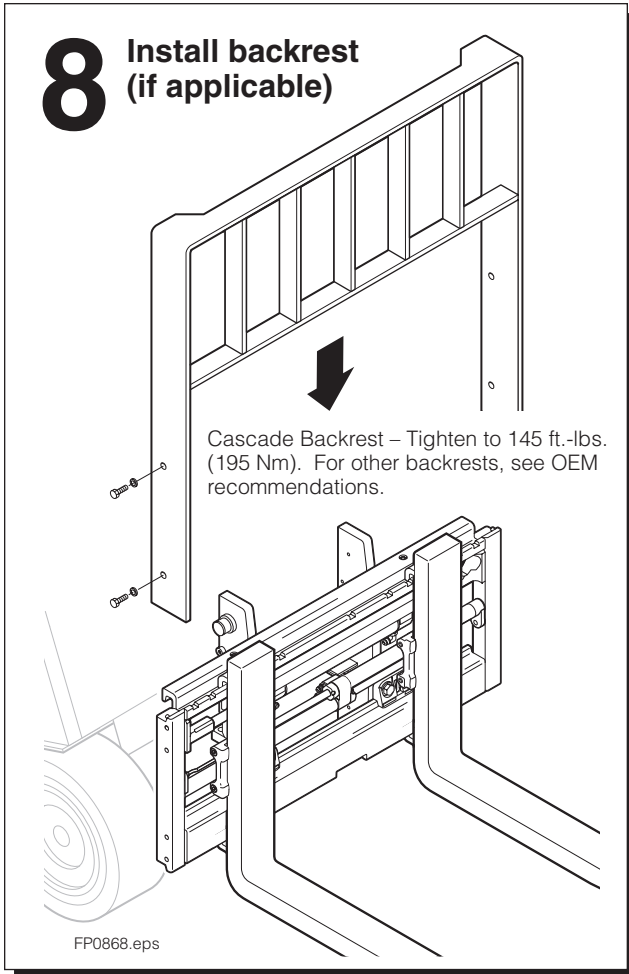

FP0868.eps



WARNING: Truck control handle and attachment function activation shown here conforms to ASME/ANSI B56.1 recommended practices. Failure to follow these practices may lead to serious bodily injury or property damage. End user, dealer and OEMs should review any deviation from the practices for safe operation.

SIDESHIFTING / FORK POSITIONING WITH SOLENOID VALVE

- A** Sideshift Left
- A** Open/Spread Forks (press knob button)
- B** Sideshift Right
- B** Close Forks (press knob button)

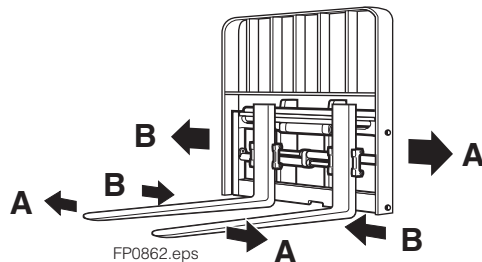

FP0862.eps

9 Lubrication

Fork Positioner/Sideshifter is prelubed at the factory and requires no lubrication for installation. Use graphite dry lube for fork bars as required ('Slip Plate Aerosol', 'GraphoKote' or equivalent).

After use, lubricate the Fork Positioner/Sideshifter as described in the Periodic Maintenance Section in this manual.

10 Cycle Fork Positioner functions

- Open and close forks several times. Sideshift left and right. Check for smoothness and equal movement.
- Check for operation in accordance with ITA (ISO) standards.
- Check for leaks at fittings, valve, cylinders.
- Check that rolling hoses supplying fork position are not pinched.

AUXILIARY VALVE FUNCTIONS

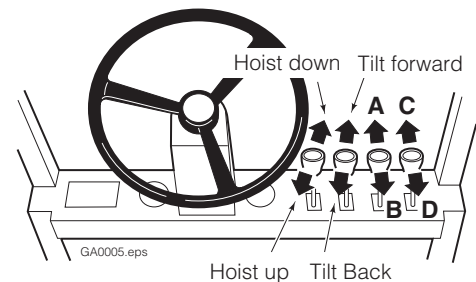

GA0005.eps

Hoist up Tilt Back

SIDESHIFTING / FORK POSITIONING

- A** Sideshift Left
- B** Sideshift Right
- C** Open/Spread Forks
- D** Close forks

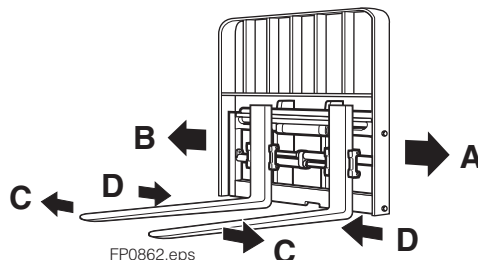

FP0862.eps

11 Adjust forks for equal movement (if required)

NOTE: Attachment is factory adjusted for equal fork movement when operated at recommended pressure and flow rate.

- A** Locate flow restrictors at each end. Loosen jam nuts and screw both flow restrictors in until they bottom. Screw each restrictor out (CCW) 1/2 turn.
- B** Open forks fully, then close. Look for unequal fork movement.
- C** On faster fork (one that bottoms first), screw flow restrictor in (CW) 1/4 turn.
- D** Repeat Steps B and C until fork movement is equal. Tighten jam nuts.

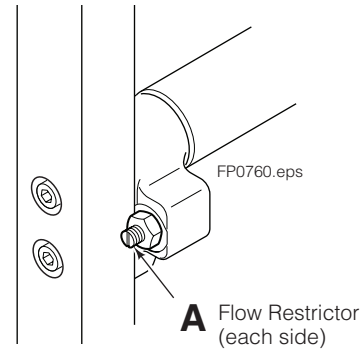

Back (Driver's View)

12 Inspect fork hooks, carriage bar clearance

NOTE: Use go/no-go Wear Gauge Part No. 209560 (Class II) or 209561 (Class III).

- A** Inspect the fork lower hooks and carriage bar. If the gauge fits between the carriage bar and lower hook, repair or replacement is needed.
- B** Inspect the upper carriage bar. If the gauge arrow touches the carriage bar, repair or replacement is needed.
- C** Inspect the fork upper hooks. If the gauge arrow touches the hook, repair or replacement is needed.

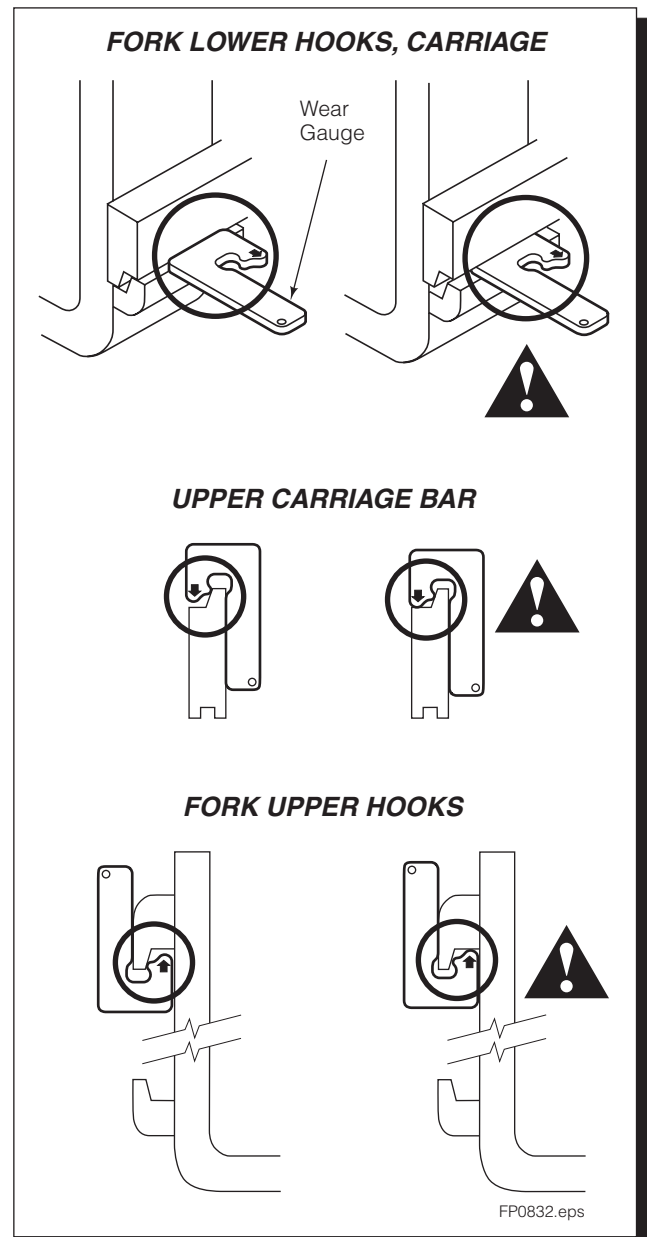



WARNING: After completing any service procedure, always test the Fork Positioner/Sideshifter through five complete cycles to make sure the attachment operates correctly before returning it to the job.

100-Hour

Every time the lift truck is serviced or every 100 hours of truck operation, whichever comes first, complete the following maintenance procedures:

- Check for loose or missing capscrews, worn or damaged hoses, and hydraulic leaks.
- Inspect sideshifter lower hooks for wear and proper clearance. Adjust if necessary. Refer to Installation Section, Step 2.
- If required, tighten capscrews as follows:
 - Fork Positioner Mounting Flanges – 50 ft.-lbs. (65 Nm)
 - Fork Carriers – 25 ft.-lbs (35 Nm)
 - FP Cylinder Rod Anchor Plugs – 50 ft.-lbs. (65 Nm)
 - Sideshifter Lower Hooks – 120 ft.-lbs. (165 Nm)

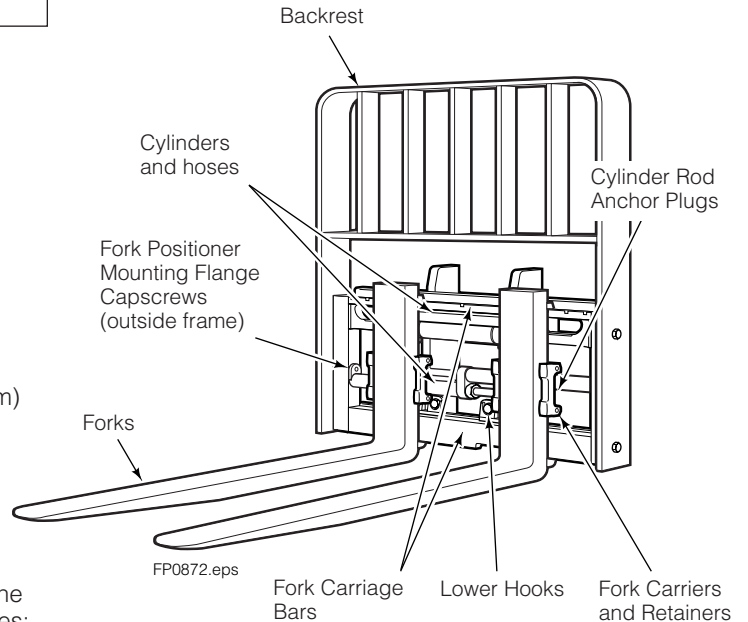

300-Hour

After each 300 hours of truck operation, in addition to the 100-hour maintenance, perform the following procedures:

- Tighten backrest capscrews (Cascade only) to 145 ft.-lbs. (195 ft.-lbs.)
- Apply general-purpose lithium-based chassis grease to sideshifter upper bearing grease fittings, fork carrier grease fittings, and sideshifter lower bearings, as shown.
- Apply graphite dry-lube to fork carriage bars as required ('Slip Plate Aerosol' - Cascade Part No. 599489, 'GraphoKote', or equivalent).

1000-Hour

After each 1000 hours of truck operation, in addition to the 100 and 300-hour maintenance, perform the following procedures:

- Inspect fork carriers for looseness on bearing tubes, and cylinder rod anchors for excessive end play. Refer to service manual for repair procedures.

NOTE: Cylinder rod anchors operate with a loose clearance.

- Inspect Sideshifter upper and lower bearings for wear. If any bearing is worn to less than 3/32 in. (2.5 mm) thickness replace the entire bearing set. Refer to service manual for repair procedures.

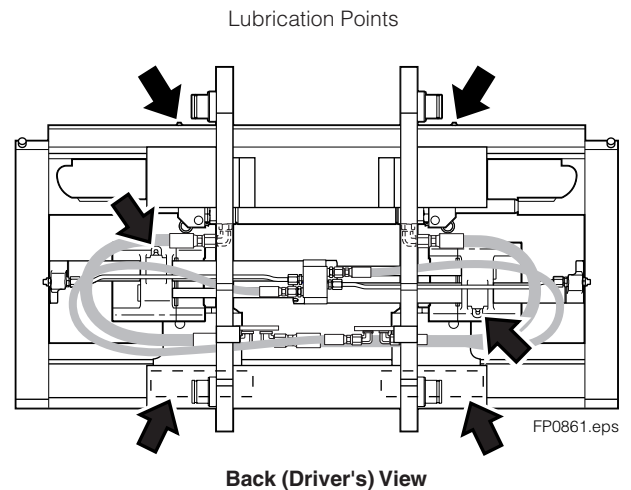

2000-Hour

After 2000 hours of truck operation, in addition to the 100, 300 and 1000-hour maintenance, forks in use shall be inspected at intervals of not more than 12 months (for single shift operations) or whenever any defect or permanent deformation is detected. Severe applications will require more frequent inspection.

Fork inspection shall be carried out by trained personnel to detect any damage that might impair safe use. Any fork that is defective shall be removed from service. Reference ANSI B56.1-2005.

Inspect for the following defects:

- Surface cracks
- Straightness of blade and shank
- Fork angle
- Difference in height of fork tips
- Positioning lock
- Wear on fork blade and shank
- Wear on fork hooks
- Legibility of marking

NOTE: Fork Safety Kit 3014162 contains wear calipers, inspection sheets and safety poster. Also available is fork hook & carriage wear gauge 209560 (Class II) and 209561 (Class III).

R ECOMMENDED SPARE PARTS

FORK POSITIONER / SIDESHIFTER				UNITS SERVICED		
35K PART NO.	55K PART NO.	70K PART NO.	DESCRIPTION	1-5 QTY.	6-19 QTY.	20-50 QTY.
FORK POSITIONER						
6055389	6055389	6055389	Cylinder Service Kit	0	4	6
6055390	6055390	6055390	Composite Bearing Service Kit	1	2	4
6055391	6055391	6055391	Bronze Bearing Service Kit	1	2	4
6039245	6039245	6039245	Mounting Shims	4	6	8
SIDESHIFTER						
8508374	8508374	8508375	Upper Bearing	8	16	32
8508376	8508376	8508377	Lower Bearing	6	12	24
8508373	8508373	8508373	Lower Hook	0	2	4
684295	684295	684295	Capscrew	0	4	8
667225	667225	667225	Washer	0	4	8
6020048	6020048	6021760	Cylinder Assembly	0	0	1
6017490	6017490	6017490	Cylinder Service Kit	1	2	4

P UBLICATIONS

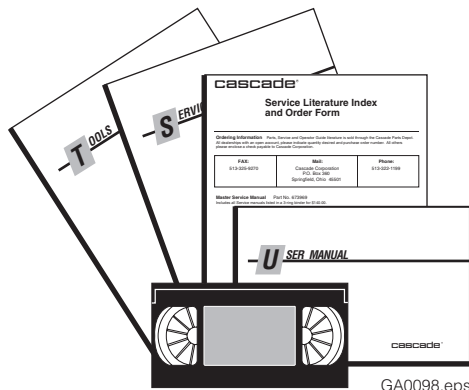

PART NO.	DESCRIPTION
6054520	User Manual
6053927	Service Manual
679929	Tool Catalog
673964	Literature Order Form

Do you have questions you need answered right now? Call your nearest Cascade Service Department. Visit us online at www.cascorp.com

AMERICAS

**Cascade Corporation
Parts Sales**
2501 Sheridan Ave.
Springfield, OH 45505
Tel: 888-CASCADE (227-2233)
Fax: 888-329-0234

Cascade Canada Inc.
5570 Timberlea Blvd.
Mississauga, Ontario
Canada L4W-4M6
Tel: 905-629-7777
Fax: 905-629-7785

Cascade do Brasil
Rua João Guerra, 134
Macuco, Santos - SP
Brasil 11015-130
Tel: 55-13-2105-8800
Fax: 55-13-2105-8899

EUROPE-AFRICA

**Cascade Italia S.R.L.
European Headquarters**
Via Dell'Artigianato 1
37050 Vago di Lavagno (VR)
Italy
Tel: 39-045-8989111
Fax: 39-045-8989160

Cascade (Africa) Pty. Ltd.
PO Box 625, Isando 1600
60A Steel Road
Sparton, Kempton Park
South Africa
Tel: 27-11-975-9240
Fax: 27-11-394-1147

ASIA-PACIFIC

Cascade Japan Ltd.
2-23, 2-Chome,
Kukuchi Nishimachi
Amagasaki, Hyogo
Japan, 661-0978
Tel: 81-6-6420-9771
Fax: 81-6-6420-9777

Cascade Korea
121B 9L Namdong Ind.
Complex, 691-8 Gojan-Dong
Namdong-Ku
Inchon, Korea
Tel: +82-32-821-2051
Fax: +82-32-821-2055

Cascade-Xiamen
No. 668 Yangguang Rd.
Xinyang Industrial Zone
Haicang, Xiamen City
Fujian Province
P.R. China 361026
Tel: 86-592-651-2500
Fax: 86-592-651-2571

**Cascade India Material
Handling Private Limited**
No 34, Global Trade Centre
1/1 Rambaugh Colony
Lal Bahadur Shastri Road,
Navi Peth, Pune 411 030
(Maharashtra) India
Phone: +91 020 2432 5490
Fax: +91 020 2433 0881

Cascade Australia Pty. Ltd.
1445 Ipswich Road
Rocklea, QLD 4107
Australia
Tel: 1-800-227-223
Fax: +61 7 3373-7333

Cascade New Zealand
15 Ra Ora Drive
East Tamaki, Auckland
New Zealand
Tel: +64-9-273-9136
Fax: +64-9-273-9137

**Sunstream Industries
Pte. Ltd.**
18 Tuas South Street 5
Singapore 637796
Tel: +65-6795-7555
Fax: +65-6863-1368

