

# **S**ERVICE MANUAL

---

# ***F-Series***

## ***Sideshifter***

*Manual Number 220526-R5*

**cascade**<sup>®</sup>  
**corporation**

Cascade is a Registered Trademark of Cascade Corporation

	Page
<b>INTRODUCTION, Section 1</b>	
Introduction	1
Special Definitions	1
<b>PERIODIC MAINTENANCE, Section 2</b>	
100-Hour Maintenance	2
300-Hour Maintenance	2
1000-Hour Maintenance	2
2000-Hour Maintenance	2
<b>TROUBLESHOOTING, Section 3</b>	
General Procedures	3
Truck System Requirements	3
Tools Required	3
Troubleshooting Chart	3
Plumbing	4
Hosing Diagram	4
Hydraulic Schematic	4
Sideshift Function	5
<b>SERVICE, Section 4</b>	
Sideshifter Removal	6
Bearings	7
Lubrication	7
Service	7
Cylinder	8
Removal, Inspection, Replacement	8
Rod Seal Replacement	9
<b>SPECIFICATIONS, Section 5</b>	
Specifications	10
Hydraulics	10
Auxiliary Valve Functions	10
Truck Carriage	10
Torque Values	11

## 1.1 Introduction

This manual provides Periodic Maintenance, Troubleshooting, Service and Specifications for F-Series Sideshifters.

In any communication about the Sideshifter, refer to the product I.D. number stamped on the back surface of the left vertical bar (driver's view) as shown.

**IMPORTANT:** All hosing and flared fittings on F-Series attachments are JIC as standard, with face seal as an option.

**NOTE:** Specifications are shown in both U.S. and (Metric) units. All fasteners have a torque value range of  $\pm 10\%$  of stated value.

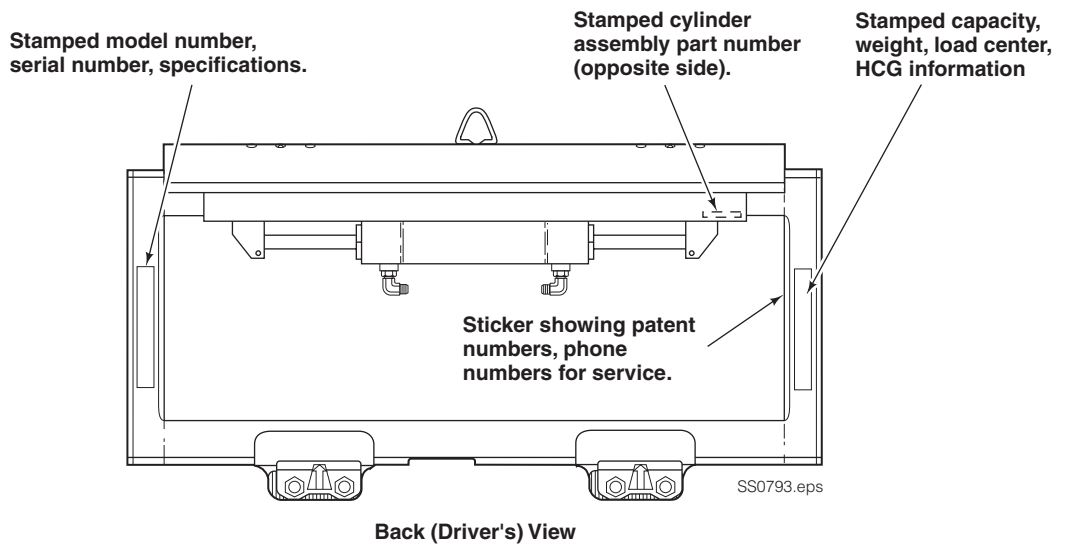

## 1.2 Special Definitions

The statements shown appear throughout this Manual where special emphasis is required. Read all WARNINGS and CAUTIONS before proceeding with any work. Statements labeled IMPORTANT and NOTE are provided as additional information of special significance or to make the job easier.

 **WARNING** - A statement preceded by WARNING is information that should be acted upon to prevent **bodily injury**. A WARNING is always inside a ruled box.

**CAUTION** - A statement preceded by CAUTION is information that should be acted upon to prevent machine damage.

**IMPORTANT** - A statement preceded by IMPORTANT is information that possesses special significance.

**NOTE** - A statement preceded by NOTE is information that is handy to know and may make the job easier.



**WARNING:** If the fork locking pin is not fully engaged, the fork could become disengaged from the carriage.

**WARNING:** After completing any service procedure, always test the attachment through five complete cycles. First test with no load, then test with a load to make sure the attachment operates correctly before returning it to the job.

## 2.1 100-Hour Maintenance

Every time the lift truck is serviced or every 100 hours of truck operation, complete the following maintenance procedures:

- Check for loose or missing bolts, worn or damaged hoses, hydraulic leaks, and damaged or missing fork stops.
- Inspect lower hooks for wear and proper clearance. Adjust if necessary, refer to Section 4.1, step 7 . Tighten lower hook capscrews to:

**Class II/III** – 120 ft.-lbs (165 Nm)

**Class IV** – 235 ft.-lbs (320 Nm)

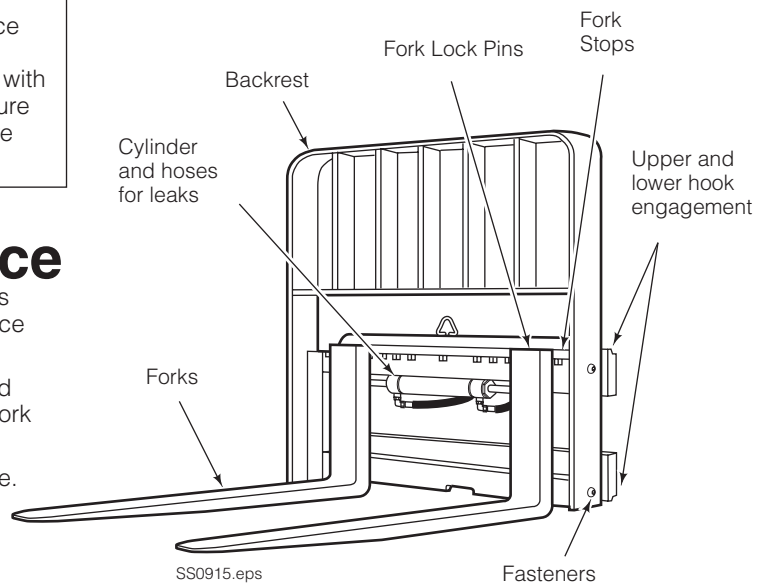

## 2.2 300-Hour Maintenance

After each 300 hours of truck operation, in addition to the 100-hour maintenance, perform the following procedures:

- **Cascade Backrests** – Tighten backrest capscrews to 145 ft.-lbs. (195 Nm).
- Apply general-purpose chassis grease to Sideshifter upper and lower bearings.

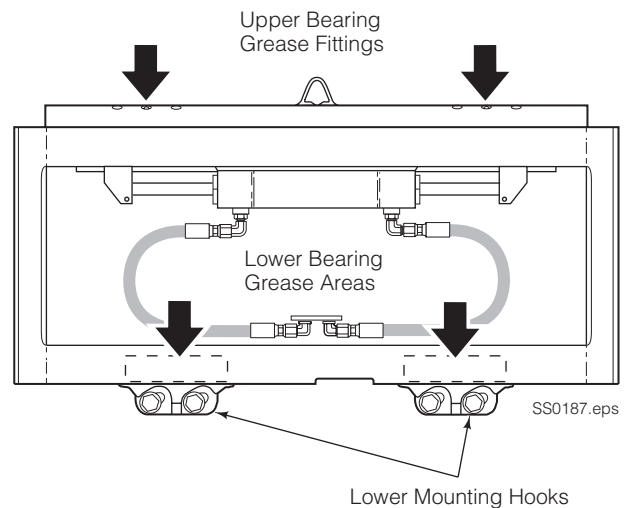

## 2.3 1000-Hour Maintenance

After each 1000 hours of truck operation, in addition to the 100 and 300-hour maintenance, perform the following procedures:

- Inspect upper and lower bearings for wear. If any bearing is worn to less than 3/32 in. (2.5 mm) thickness, replace the entire bearing set. Refer to Section 4.2-2.

## 2.4 2000-Hour Maintenance

After 2000 hours of truck operation, in addition to the 100, 300 and 1000-hour maintenance, forks in use shall be inspected at intervals of not more than 12 months (for single shift operations) or whenever any defect or permanent deformation is detected. Severe applications will require more frequent inspection.

Fork inspection shall be carried out by trained personnel to detect any damage that might impair safe use. Any fork that is defective shall be removed from service. Reference ANSI B56.1-2005.

## 2000-Hour (Continued)

Inspect for the following defects:

- Surface cracks
- Straightness of blade and shank
- Fork angle
- Difference in height of fork tips
- Positioning lock
- Wear on fork blade and shank
- Wear on fork hooks
- Legibility of marking

**NOTE:** Fork Safety Kit 3014162 contains wear calipers, inspection sheets and safety poster. Also available is fork hook & carriage wear gauge 209560 (Class II), 209561 (Class III) and 6105257 (Class IV).

## 3.1 General Procedures

### 3.1-1 Truck System Requirements

- Truck hydraulic pressure should be within the range shown in Specifications, Section 5.1. **PRESSURE TO THE ATTACHMENT MUST NOT EXCEED 3500 psi (245 bar).**
- Truck hydraulic flow should be within the range shown in Specifications, Section 5.1.
- Hydraulic fluid supplied to the attachment must meet the requirements shown in Specifications, Section 5.1.

### 3.1-2 Tools Required

In addition to a normal selection of mechanic's hand tools, the following are required:

- In-line Flow Meter Kit:  
10 GPM (37 L/min) – Cascade Part No. 671476.  
20 GPM (75 L/min) – Cascade Part No. 671477.
- Pressure Gauge Kit:  
5000 psi (345 bar) – Cascade Part No. 671212.
- Assorted fittings, hoses, and quick-disconnect couplers as required.

### 3.1-3 Troubleshooting Chart

**Determine All The Facts** – It is important to gather all the facts about the problem before beginning any service procedures. The first step is to talk to the equipment operator. Ask for a complete description of the malfunction. Guidelines below and on the following pages can then be used as a starting point to begin troubleshooting.

#### Sideshift Circuit

- Attachment will not sideshift.
  - Attachment sideshifts slowly.
- To correct these problems, see Section 3.3.



**WARNING:** Before servicing any hydraulic component, relieve pressure in the Attachment system. Turn the truck off and move the truck auxiliary control lever several times in both directions.

After completing any service procedure, always test the attachment through several cycles. First test the attachment empty to bleed any air trapped in the system to the truck tank. Then test the attachment with a load to be sure it operates correctly before returning to the job.

Stay clear of the load while testing. Do not raise the load more than 4 in. (10 cm) off the floor while testing.

#### Flow Meter Kits: 671476 (10 GPM – 37 L/min) 671477 (20 GPM – 75 L/min)

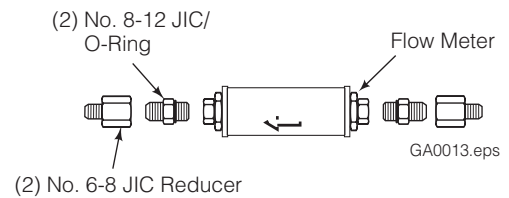

#### Pressure Gauge Kit: 671212

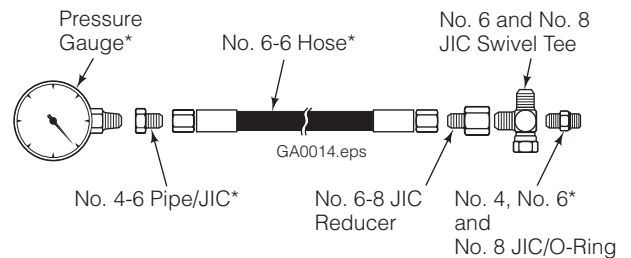

#### Quick-Disconnect Couplers

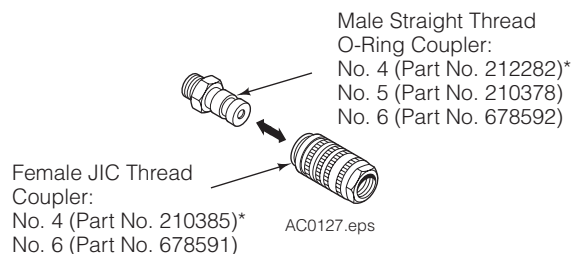

**\* NOTE: Diagnostics Kit 394382 includes items marked.**

## 3.2 Plumbing

### 3.2-1 Hosing Diagram

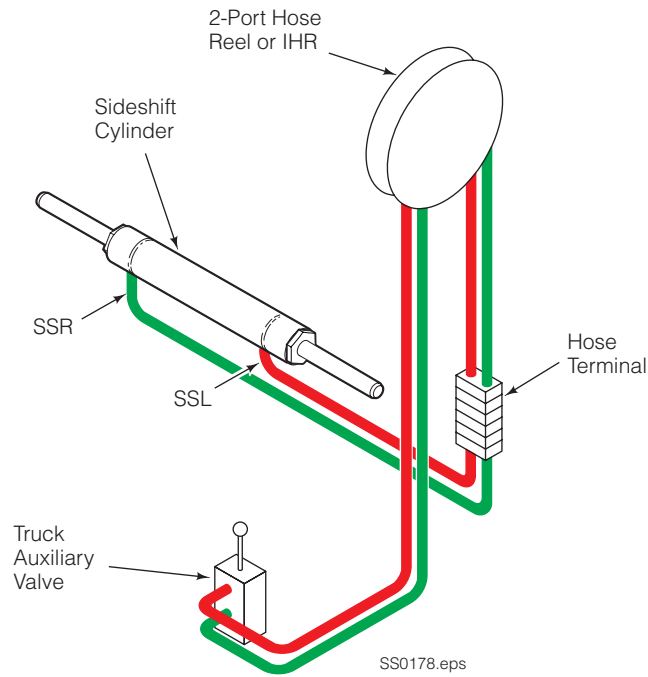

### 3.2-2 Hydraulic Schematic

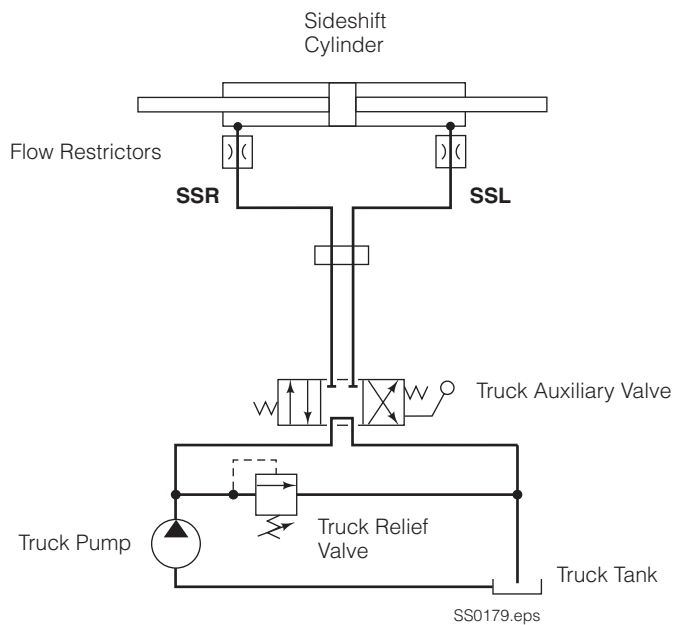

## 3.3 Sideshift Function

There are six potential problems that could affect the sideshifting function:

- Inadequate upper bearing lubrication or worn bearings. Refer to Section 4.2.
- Incorrect hydraulic pressure or flow from lift truck.
- External leaks.
- Lower mounting hooks installed with incorrect clearance. Refer to Section 4.1 Step 7.
- Worn or defective cylinder seals. Refer to Section 4.3.
- Cylinder fittings or flow restrictors plugged, incorrect type, or not installed properly. Refer to Section 4.3.



**WARNING:** Before disconnecting hoses, relieve pressure in the Attachment hydraulic system. Turn the truck off and move the truck auxiliary control handle several times in both directions.

### 3.3-2 Supply Circuit Test

- 1 Check the pressure supplied by the truck at the carriage hose terminals. Pressure must be within the range shown in Specifications, Section 5.1.  
**PRESSURE TO THE SIDESHIFTER MUST NOT EXCEED 3500 PSI (245 BAR)**
- 2 Check the flow volume at the carriage hose terminal. Flow must be within the range shown in Specifications, Section 5.1.
- 3 Sideshift fully to the left and hold the lever in the SIDESHIFT LEFT position for a few seconds. Release the lever and check for external leaks at fittings, hoses and cylinder rod ends.

### 3.3-3 Sideshift Circuit Test

- 1 Sideshift fully to the left. Turn the truck off and relieve Attachment system pressure. Disconnect the SIDESHIFT RIGHT supply hose from the truck hose terminal and route to a drain bucket. Cap the supply fitting.
- 2 Start the truck and actuate the SIDESHIFT LEFT lever for 5 seconds:
  - If there is substantial hydraulic flow out of the drain hose, the sideshift cylinder is faulty and requires replacement. Refer to Section 4.3.
  - If there is no hydraulic flow out of the hose, check for plugged or incorrectly-installed flow restrictor washers and fittings. If there is still no hydraulic flow, the problem is not hydraulic. Refer to Section 3.3.

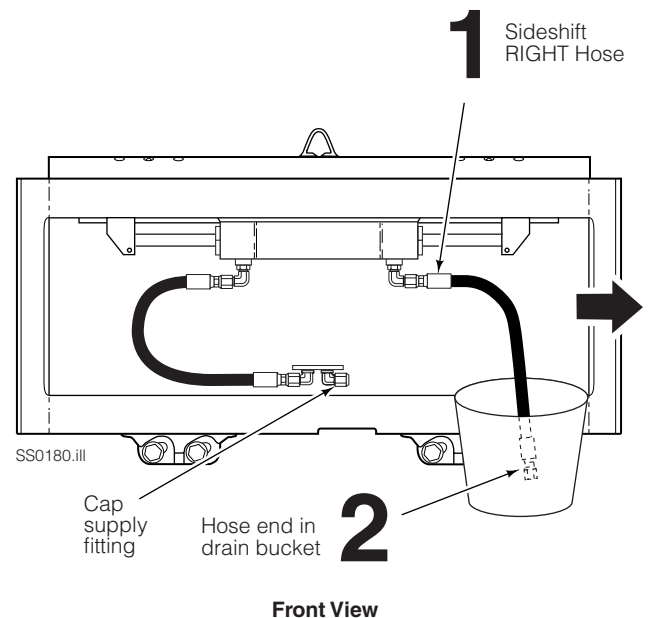

## 4.1 Sideshifter Removal

- 1 Remove the forks from the attachment.
- 2 Remove the backrest from the attachment.

**Cascade Backrests** – For reassembly, tighten the capscrews to 145 ft.-lbs. (195 Nm).

Refer to the truck service manual for truck manufacturer's backrest.



**WARNING:** Before disconnecting hoses, relieve pressure in the attachment hydraulic system. Turn the truck off and move the truck control handle several times in both directions.

- 3 Disconnect the hoses from the cylinder. Tag hoses for reassembly.
- 4 If the hydraulic cylinder is to be serviced, loosen the seal carriers before removing the attachment. For reassembly, tighten seal carriers to:
  - Class II/III** – 120 ft.-lbs. (165 Nm)
  - Class IV** – 235 ft.-lbs. (320 Nm)
- 5 Remove the lower mounting hooks and inspect for wear. Refer to illustration. Replace if beyond wear limit.
- 6 Attach an overhead hoist to the attachment and lift away from the truck carriage.
- 7 For installation, reverse the above procedures with the following exceptions:

- Clean and inspect carriage bars for damage and smoothness. Bars should be parallel and ends flush. Repair any protruding welds or damaged notches by grinding, filing or welding.
- Clean all bearing areas of built-up dirt and grease.
- Inspect bearings for wear and replace as necessary. Refer to Section 4.2-2.
- Install and adjust lower hooks as shown below. **CAUTION:** Lower bearing clearance must be adjusted as shown for proper sideshifter operation.
- Lubricate both upper and lower bearings with general-purpose chassis grease.

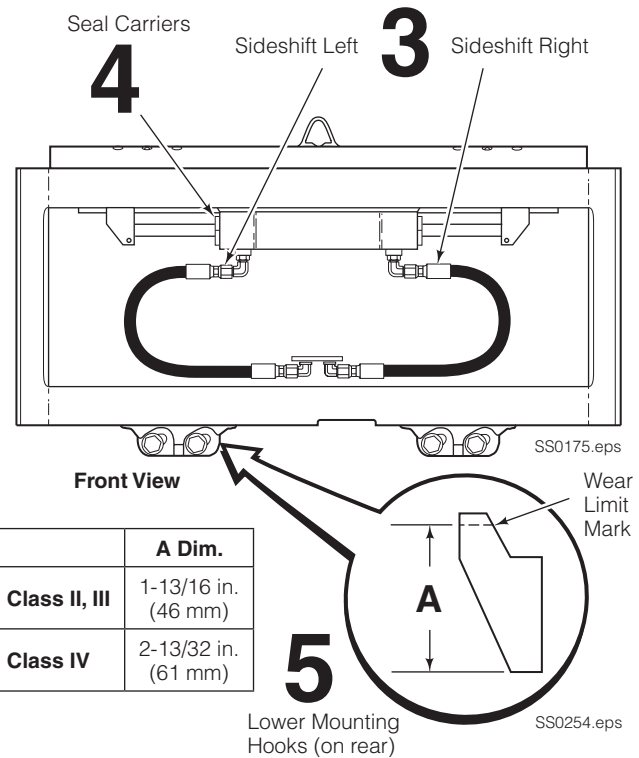

**WARNING:** Check the attachment weight (located on the nameplate) to make sure the overhead hoist and chains or straps are at least the rated capacity of the attachment.

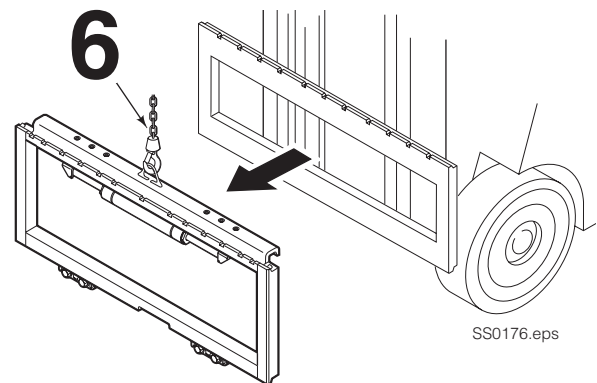

## 7

### BOLT-ON

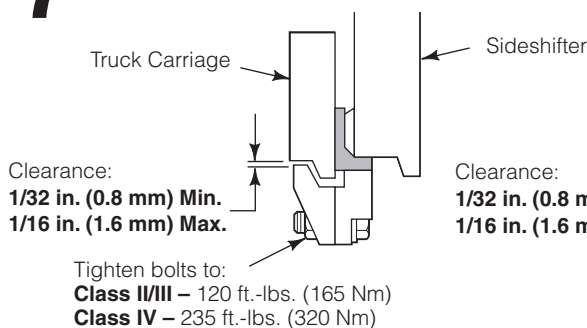

### QUICK-CHANGE

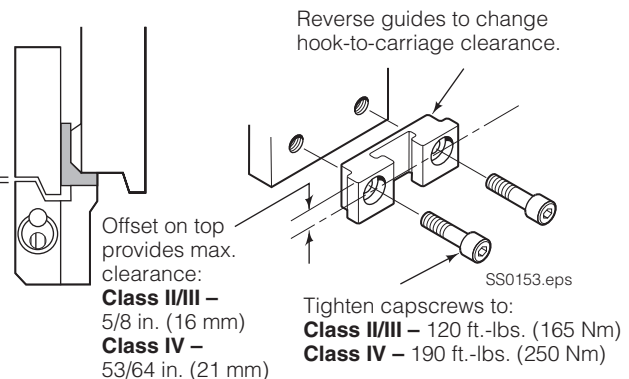

## 4.2 Bearings

### 4.2-1 Bearing Lubrication

Lubricate both the upper and lower bearings with chassis grease every 300 hours or 4 weeks of operation (whichever occurs first). In contaminated environments lubricate every week or as required.

### 4.2-2 Bearing Service

- 1 Remove the attachment from the truck as described in Section 4.1 and lay flat on a pallet or workbench.
- 2 Remove the retainer pins and remove the cylinder/anchor bracket assembly from the frame.
- 3 Remove the upper bearings by driving them out of the frame. If any bearing is worn to less than  $\frac{3}{32}$  in. (2.5 mm) thickness, replace all the upper bearings.

**IMPORTANT:** Use a wood block or plastic hammer to fully seat new bearings into upper frame. Refer to illustration. Proper lower hook clearance requires that upper bearings be fully seated into upper frame.

- 4 Remove the lower bearings by prying them from the lower hook mounts. If any bearing is worn to less than  $\frac{3}{32}$  in. (2.5 mm) thickness, replace all the lower bearings. **NOTE:** Bronze lower bearings are retained in place by a roll pin. Remove the bearing by pulling or prying the pin out far enough to release the bearing.
- 5 For reassembly, reverse the above procedures.

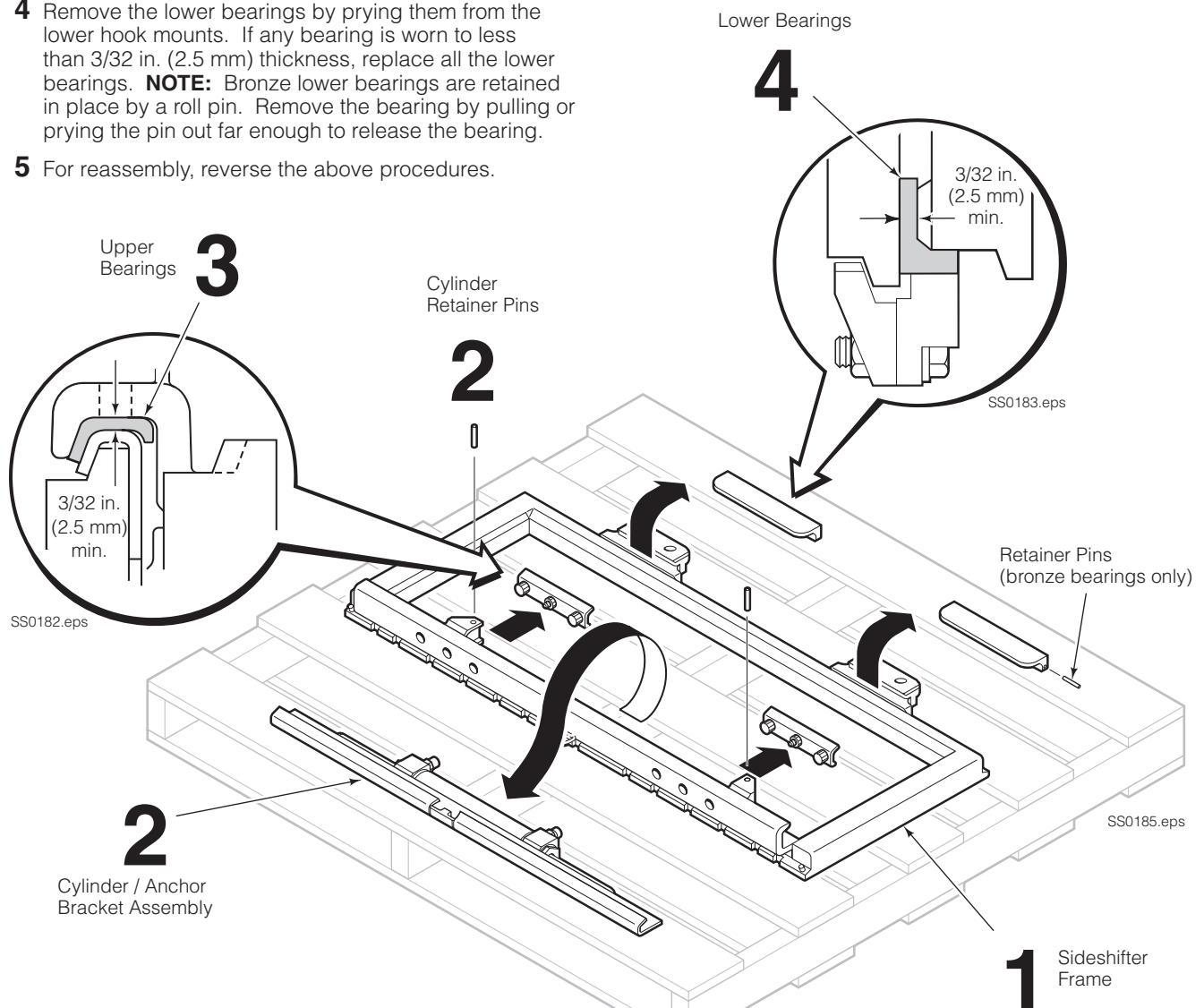
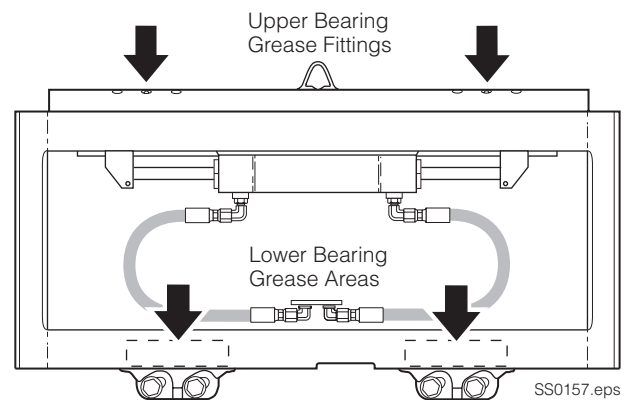

## 4.3 Cylinder

### 4.3-1 Removal, Inspection and Replacement

**NOTE:** The attachment must be removed from the truck in order to replace the cylinder/anchor bracket assembly and the cylinder rod seals.



**WARNING:** Before removing hoses or hydraulic components, relieve pressure in the Attachment hydraulic system. Turn the truck off and move the truck control handle several times in both directions.

- 1 Remove the attachment from the truck as described in Section 4.1 and lay flat on a pallet or workbench.
- 2 Remove the retainer pins and remove the cylinder/anchor bracket assembly from the frame. Refer to illustration on previous page.
- 3 Inspect the outside of the cylinder shell for damage that could impair performance or cause leaks under pressure. If damage is found, replace the complete cylinder assembly. **IMPORTANT:** Make sure cylinder fittings and flow restrictors are installed as shown.
- 4 Inspect the cylinder rods for damage. If bent or scored, replace the complete cylinder assembly.
- 5 Inspect the anchor bracket and centering tab for damage. If damage is found, replace the complete cylinder assembly.
- 6 For reassembly, reverse the above procedures with the following exceptions:
  - Replace the cylinder retainer pins with new pins.

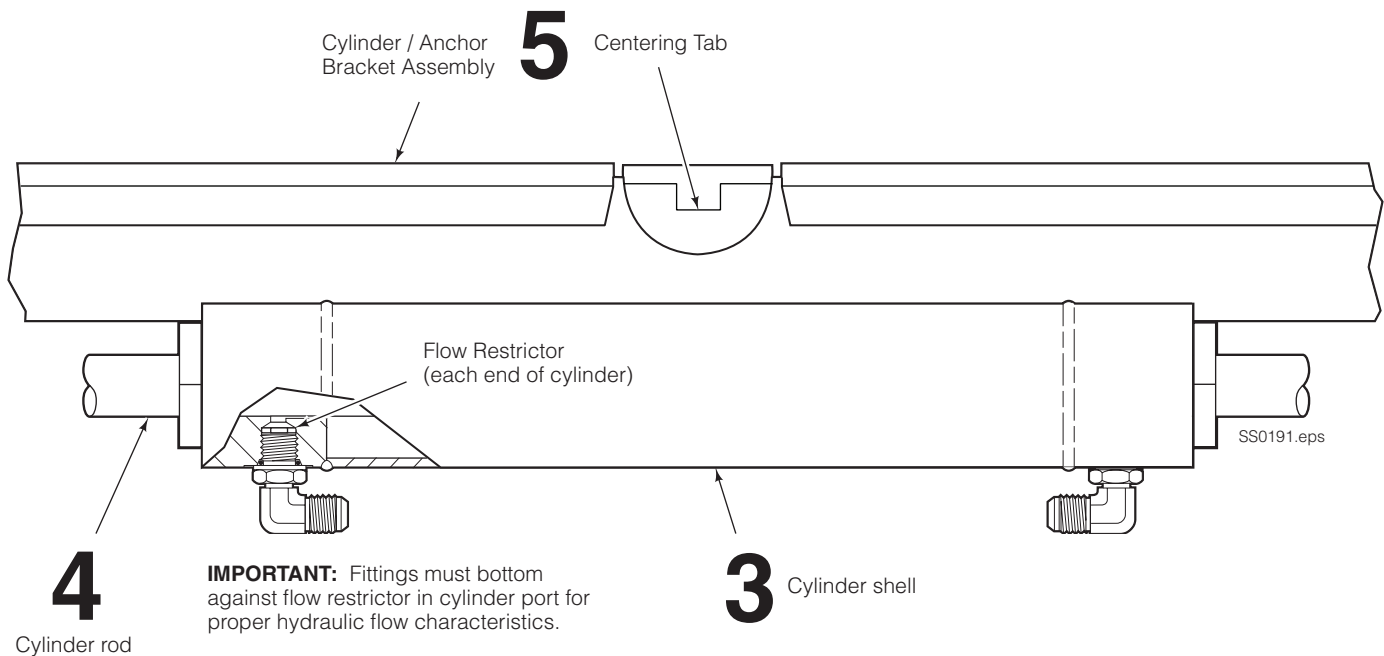

## 4.3-2 Rod Seal Replacement

**NOTE:** The attachment must be removed from the truck to replace the cylinder rod seals.

- 1 Loosen the seal carriers, then remove the attachment from the truck as described in Section 4.1.
- 2 Remove the cylinder/anchor bracket assembly from the attachment as described in Section 4.3-1.
- 3 Clamp the cylinder/anchor bracket in a soft-jawed vise. **CAUTION:** Do not clamp on the cylinder shell.
- 4 With the cylinder rod centered, unscrew the seal carriers from each end of the cylinder. Slide the seal carriers off the cylinder rod. **NOTE:** If installing new seal carriers loaded with seals, proceed to Step 8.
- 5 Remove the seals and O-ring by prying them out with a brass O-ring tool as shown. **CAUTION:** Do not scratch the seal grooves.
- 6 Clean the seal carrier and cylinder rod with cleaning solvent. Break any sharp edges on the cylinder rod end. Lubricate the new seals and O-rings with petroleum jelly.
- 7 Install the seals into the seal carrier grooves. Form the seals into a 'kidney' shape to ease placement into the bore. Note the direction of the U-cup seals: **Pressure seals are installed with the lip toward the center of the cylinder** (see illustration below).
- 8 Apply a thick film of petroleum jelly to the inside of the seal carrier and carefully slide onto the cylinder rod. Screw the seal carriers into the cylinder shell
- 9 For reassembly, reverse the above procedures with the following exceptions:
  - After the sideshifter is remounted on the truck, tighten the seal carriers to 120 ft.-lbs. (165 Nm).

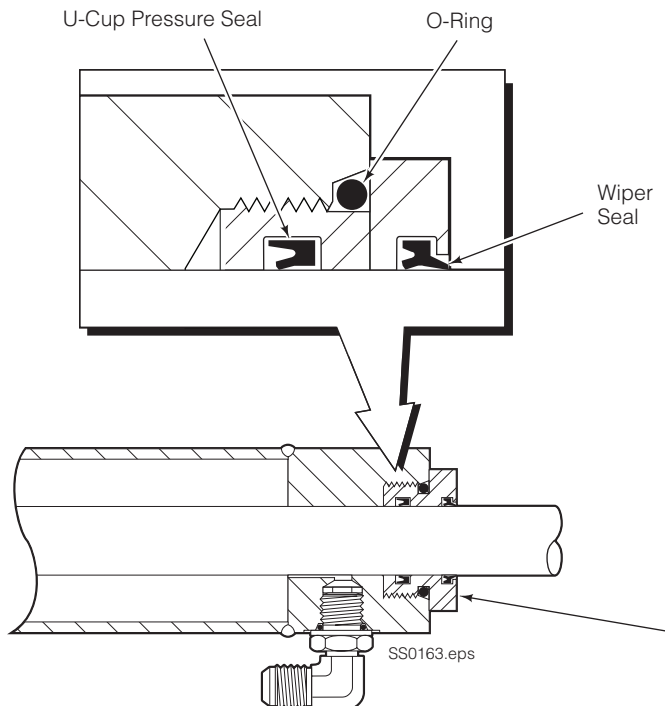
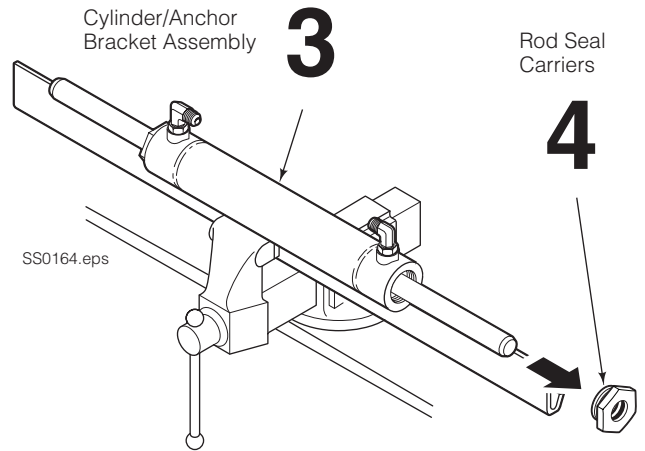

**8** Rod Seal Carrier

## 5.1 Specifications

### 5.1-1 Hydraulics

#### Truck Relief Setting

2000 psi (140 bar) Recommended  
3500 psi (240 bar) Maximum

#### Truck Flow Volume <sup>①</sup>

	Min. <sup>②</sup>	Recommended	Max. <sup>③</sup>
<b>55F, 65F</b>	1 GPM (4 L/min.)	2 GPM (7.5 L/min.)	3 GPM (12 L/min.)
<b>100F, 120F, 150F, 165F</b>	1 GPM (4 L/min.)	4 GPM (16 L/min.)	5 GPM (20 L/min.)

- ① Cascade sidershifters are compatible with SAE 10W petroleum base hydraulic fluid meeting Mil. Spec. MIL-0-5606 or MIL-0-2104B. Use of synthetic or aqueous base hydraulic fluid is not recommended. If fire resistant hydraulic fluid is required, special seals must be used. Contact Cascade.
- ② Flow less than recommended will result in slow sidershift speed.
- ③ Flow greater than maximum can result in excessive heating, reduced system performance and short hydraulic system life.

#### Hoses and Fittings

All supply hoses and fittings should be at least No. 4 with 3/16 in. (5 mm) minimum I.D.

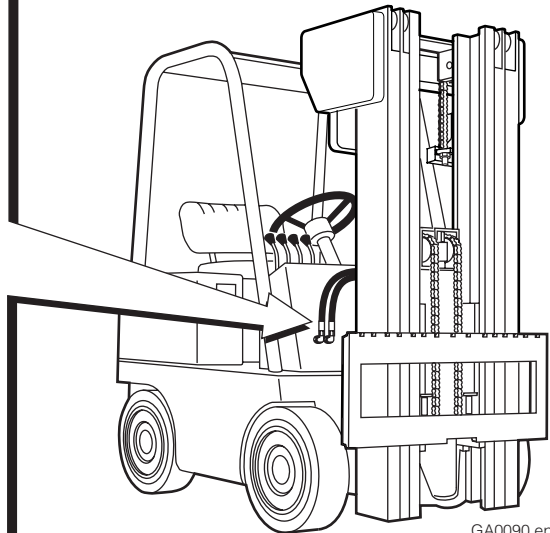

GA0090.eps

### 5.1-2 Auxiliary Valve Functions

Check for compliance with ITA (ISO) standards:

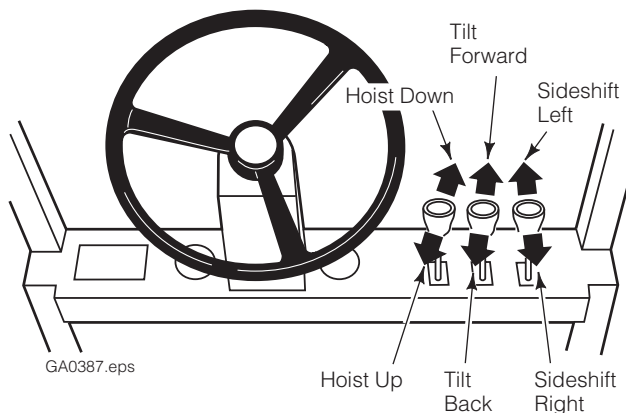

GA0387.eps

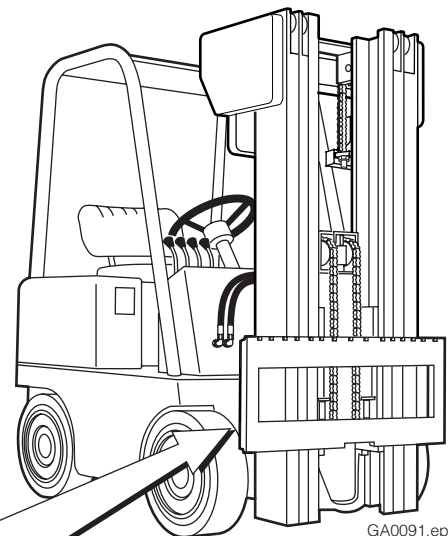

GA0091.eps

### 5.1-3 Truck Carriage

A	Carriage Mount Dimension (A) ITA (ISO)	
	Minimum	Maximum
<b>Class II</b>	14.94 in. (380.0 mm)	15.00 in. (381.0 mm)
<b>Class III</b>	18.68 in. (474.5 mm)	18.74 in. (476.0 mm)
<b>Class IV</b>	23.44 in. (595.5 mm)	23.50 in. (597.0 mm)

GA0028.eps

## 5.1-4 Torque Values

Fastener torque values for the F-Series Sideshifter are shown in the table below in both U.S. and Metric units. Torque values are also specified throughout the manual.

**NOTE:** All fasteners have a torque value range of  $\pm 10\%$  of stated value.

Ref.	Fastener	Size	Ft.-lbs.	Nm
<b>1</b>	Lower Hooks	M16 5/8 in.	120	165
<b>2</b>	Backrest	M16	145	195
<b>3</b>	Rod Seal Carrier	—	120	165
<b>4</b>	Pallet Guard	M16	145	195

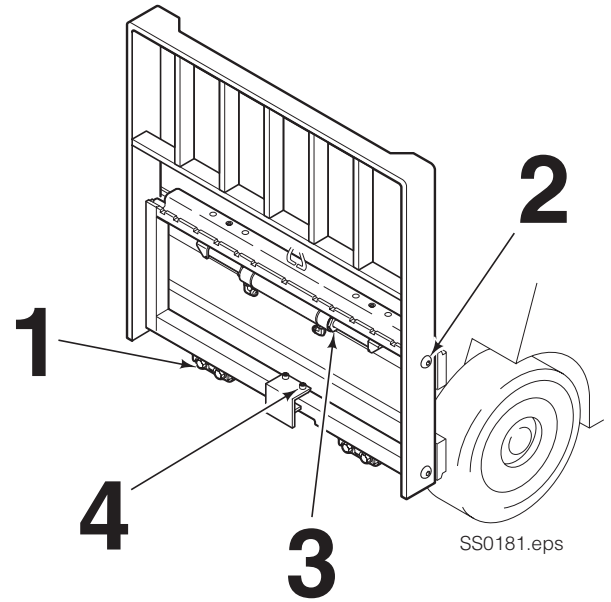

**Do you have questions you need answered right now?** Call your nearest Cascade Service Department. Visit us online at [www.cascorp.com](http://www.cascorp.com)

## **AMERICAS**

**Cascade Corporation  
U.S. Headquarters**  
2201 NE 201st  
Fairview, OR 97024-9718  
Tel: 800-CASCADE (227-2233)  
Fax: 888-329-8207

**Cascade Canada Inc.**  
5570 Timberlea Blvd.  
Mississauga, Ontario  
Canada L4W-4M6  
Tel: 905-629-7777  
Fax: 905-629-7785

**Cascade do Brasil**  
Rua João Guerra, 134  
Macuco, Santos - SP  
Brasil 11015-130  
Tel: 55-13-2105-8800  
Fax: 55-13-2105-8899

## **EUROPE-AFRICA**

**Cascade Italia S.R.L.  
European Headquarters**  
Via Dell'Artigianato 1  
37030 Vago di Lavagno (VR)  
Italy  
Tel: 39-045-8989111  
Fax: 39-045-8989160

**Cascade (Africa) Pty. Ltd.**  
PO Box 625, Isando 1600  
60A Steel Road  
Sparton, Kempton Park  
South Africa  
Tel: 27-11-975-9240  
Fax: 27-11-394-1147

## **ASIA-PACIFIC**

**Cascade Japan Ltd.**  
2-23, 2-Chome,  
Kukuchi Nishimachi  
Amagasaki, Hyogo  
Japan, 661-0978  
Tel: 81-6-6420-9771  
Fax: 81-6-6420-9777

**Cascade Korea**  
121B 9L Namdong Ind.  
Complex, 691-8 Gojan-Dong  
Namdong-Ku  
Inchon, Korea  
Tel: +82-32-821-2051  
Fax: +82-32-821-2055

**Cascade-Xiamen**  
No. 668 Yangguang Rd.  
Xinyang Industrial Zone  
Haicang, Xiamen City  
Fujian Province  
P.R. China 361026  
Tel: 86-592-651-2500  
Fax: 86-592-651-2571

**Cascade India Material  
Handling Private Limited**  
No 34, Global Trade Centre  
1/1 Rambaugh Colony  
Lal Bahadur Shastri Road,  
Navi Peth, Pune 411 030  
(Maharashtra) India  
Phone: +91 020 2432 5490  
Fax: +91 020 2433 0881

**Cascade Australia Pty. Ltd.**  
1445 Ipswich Road  
Rocklea, QLD 4107  
Australia  
Tel: 1-800-227-223  
Fax: +61 7 3373-7333

**Cascade New Zealand**  
15 Ra Ora Drive  
East Tamaki, Auckland  
New Zealand  
Tel: +64-9-273-9136  
Fax: +64-9-273-9137

**Sunstream Industries  
Pte. Ltd.**  
18 Tuas South Street 5  
Singapore 637796  
Tel: +65-6795-7555  
Fax: +65-6863-1368

