

# Technical Bulletin

## D-Series Backrest Stop Block Kit 205203

This sheet describes the procedures and processes to install stop block kit 205203 to the D-Series backrest. The kit includes four stop blocks.



**WARNING:** Welding must be performed by a qualified welder familiar with this type of fabrication.

- ❶ Clean all surfaces to be welded. Remove paint, oil, grease and other contaminants. If a torch is used to remove paint it will preheat the parts.
- ❷ Locate the bars to be welded to the backrest vertically on the carriage upper and lower bars as shown. Position the bars tight against the carriage bars. Clamp in place with "C"-Clamps.
- ❸ Preheat to 100° F before welding. Do not weld in a drafty area.

❹ **WELD METHOD A** – Attach the ground wire to the backrest. Weld using FCAW (Flux Core Arc Weld) AWS E70T-5 1/16 in. (1.5 mm) diameter wire with 100% CO<sub>2</sub> shielding gas. Use the location and fillet size shown holding a close arc. Do not oscillate or use a wash bead pattern. Let the welds slow cool.

**WELD METHOD B** – Attach the ground wire to the backrest. Weld using E-7018 low hydrogen 5/32 in. electrodes. Use reverse polarity or an AC welding machine set at 145–225 amps. Do not use electrodes exposed to moisture without first re-drying them at 180–220° F for 1 to 2 hours. Use the location and fillet size shown holding a close arc. Do not oscillate or use a wash bead pattern. Let the welds slow cool.

❺ Remove slag and inspect the welds. The following defects are not allowed: cracks, porosity, inclusions and undercut. Clean the weld area and repaint.

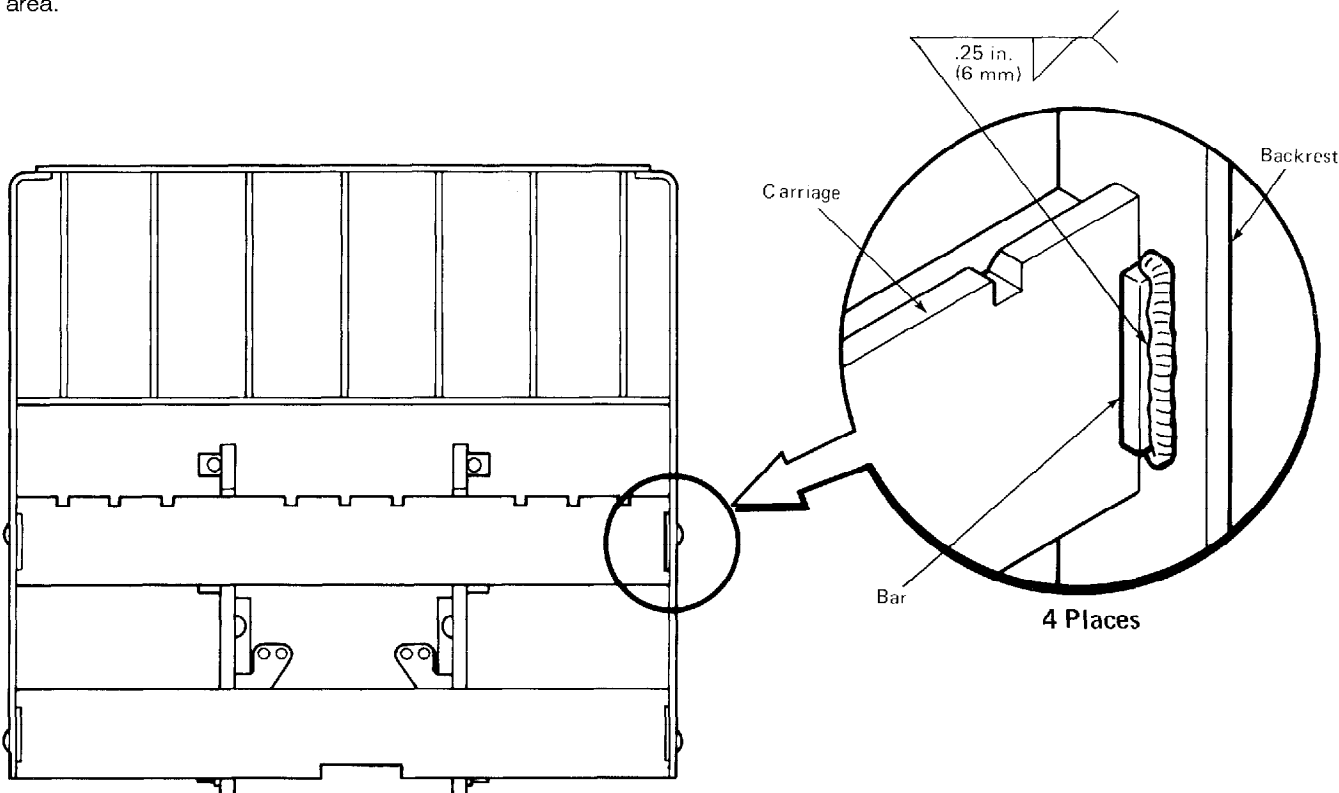

**NOTE:** This information should not be interpreted as the basis for warranty claims unless so designated.  
Part No. 205850 R-1

# cascade®

For Technical Assistance . . .

Call: 1-800-CASCADE or 503-669-6300

OR

Write: Cascade Corporation, PO Box 20187, Portland, OR 97220

To Order Parts . . .

Call: 513-322-1199

OR

Write: Cascade Corporation, 2501 Sheridan Ave., Springfield, OH 45505