



Installation Instructions

F-Series Sideshifter Guard Kits 6021376 and 6021377

This sheet provides instructions for field installing a hydraulic component guard to a Cascade F-Series Sideshifter. The kit contains fasteners and brackets to mount the guard. The brackets must be welded to the sideshifter outer frame.

- 1 Remove the sideshifter from the truck carriage.
- 2 Assemble the four brackets to the back of the guard.
- 3 Place the guard assembly inside the sideshifter frame making sure that each bracket touches the frame. The guard should be flush with the front surface of the frame with the brackets on the back side of the guard. Clean areas next to brackets for welding.
- 4 Protect the cylinder rod and bearings from weld splatter. Tack weld the brackets to the frame.
- 5 Lay the sideshifter face down. Protect the cylinder rod and bearings from weld splatter. Weld the brackets to the frame with 3/16 in. (5mm) fillet welds. Clean and repaint welds areas.
- 6 Install the sideshifter on the truck carriage. Remove the guard to install the hoses, then install the guard.

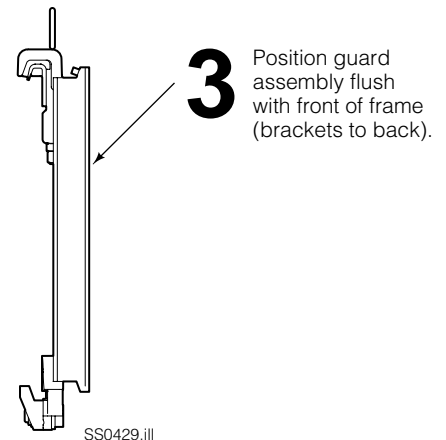
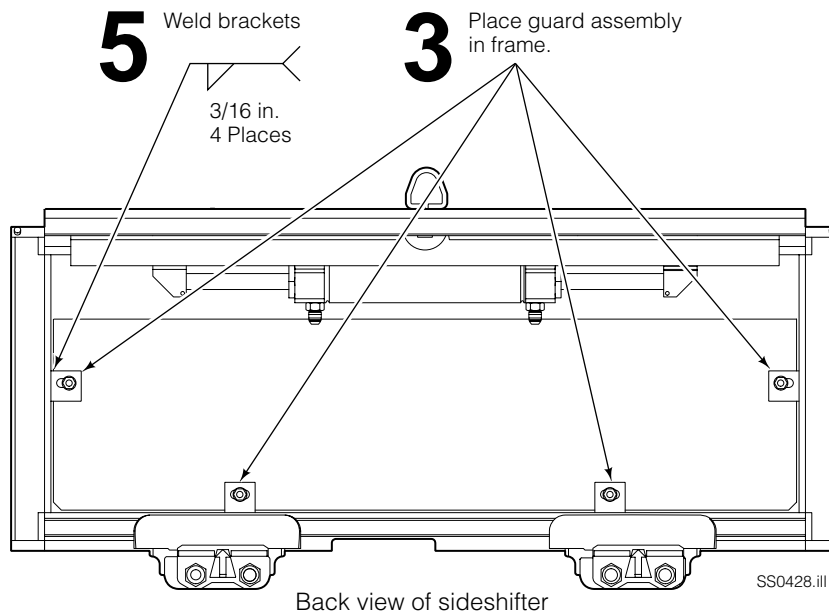
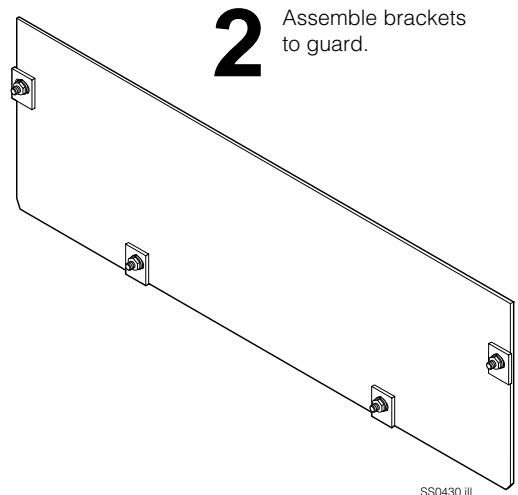

cascade[®]
corporation

For Technical Support . . .

Call: 1-800-227-2233

OR

Write: Cascade Corporation, P.O. Box 20187, Portland, OR 97294

© Cascade Corporation 2001

To Order Parts . . .

Call: 1-888-227-2233

OR

Write: Cascade Corporation, 2501 Sheridan Ave., Springfield, OH 45505

9-2001

Part No. 6021378

