



● Installation Instructions

55D, 100D

Pivot Arm Paper Roll Clamps

Serial Numbers 672375 through 675544

IMPORTANT: Field alterations may impair performance or capability and could result in loss of warranty. Consult Cascade for any required modifications.



WARNING: Rated capacity of the truck/attachment combination is a responsibility of the original truck manufacturer and may be less than shown on the attachment nameplate. Consult the truck nameplate.

● Manual Number 675276

cascade[®]

Cascade is a Registered Trademark of Cascade Corporation

A. Truck Requirements

- Truck Relief Valve Setting: 2300 psi (160 bar), maximum.
- Hydraulic Flow:

	Min.*	Recommended	Max. †
Clamp Circuit - 55D	4 GPM	7 GPM	7 GPM
100D	4 GPM	10 GPM	10 GPM
Rotate Circuit - 55D	6 GPM	10 GPM	12 GPM
100D	10 GPM	20 GPM	24 GPM

* Flow less than minimum will result in a rotate speed less than 2 rpm.
 † Flow greater than maximum can result in excessive heating, reduced system performance and short hydraulic system life.

- Recommended hose and fitting size:
 No. 6 with minimum fitting orifices of 9/32 in. (7mm).
 No. 8 with minimum fitting orifices of 13/32 in. (10mm).
- Truck carriage must conform to the industrial Truck Association (ITA) dimensional standards as shown.
- Make sure the truck carriage is clean and the notches are undamaged.
- In order to conform to industry standard practice, the hoses should be connected to the truck auxiliary valve as indicated by the chart.



Mounting	Dimension A-ITA(ISO)	
	Minimum	Maximum
Class II	14.94 in. (380.0mm)	15.00 in. (381.0mm)
Class III	18.64 in. (474.5mm)	18.74 in. (476.0mm)
Class IV	23.44 in. (595.5mm)	23.50 in. (597.0mm)

2194d

Function, in sequence of location to the operator	Attachment Movement	Motion of the operator's hand when actuating the truck auxiliary control handle while facing the load.
Rotate	Clockwise	Rearward or Up
	Counterclockwise	Forward or Down
Clamp*	Clamp	Rearward or Up
	Release	Forward or Down

*If solenoid equipped depress button for CLAMP/RELEASE functions. Release button for ROTATE.

B. Installation

- 1 Install a suitable overhead chain hoist. Set the clamp vertical.



WARNING: Make sure your overhead hoist has a rated capacity of at least 5000 lbs. (2285 kg).

- 2 Remove the lower mounting hooks.

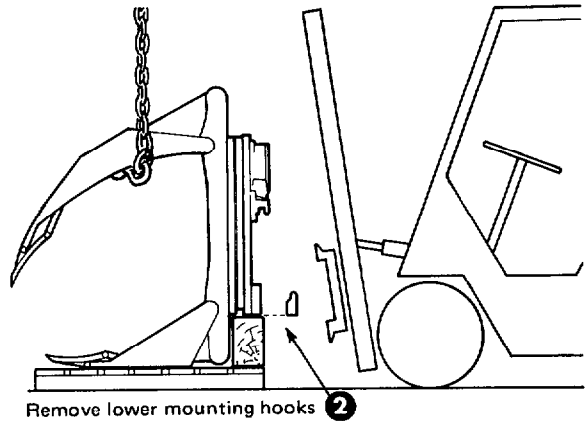

- 3 Remove the plastic cover from the drive assembly relief fitting. Check the oil level in the drive assembly. Oil level must be visible in the fill hole. Fill if necessary with Cascade Gear Lube 656300 or equivalent SAE 90 wt. lube (AGMA "mild" 6EP Gear Oil).

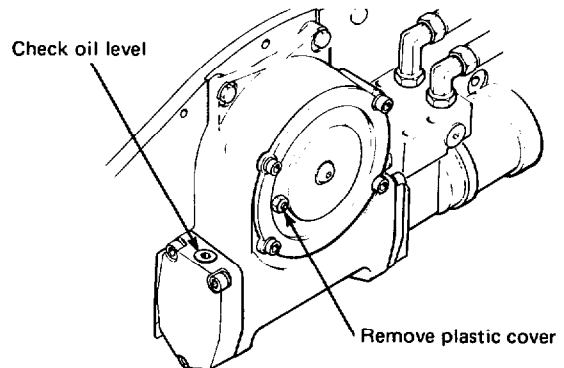

B. Installation (Continued)

- 4 Connect hydraulic hoses to the attachment fittings using Installation Kit 675158 **OR** use hoses and fittings as shown. Position the truck carriage behind the attachment to determine hose lengths required to connect hoses to the junction block/hose terminal kits or internal reeving fittings. Remove the hoses and cut to length as required.

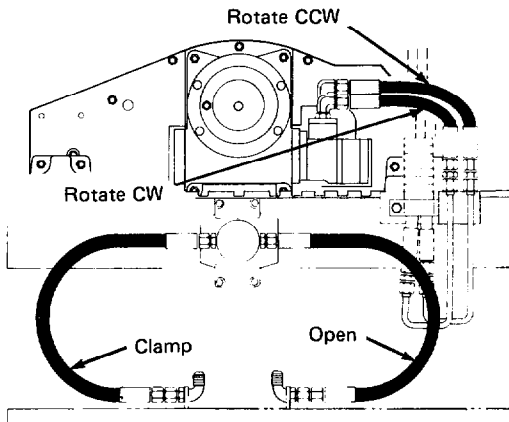

Installation using mast internal reeving with a right hand 2-Port THINLINE™ Hose Reel.

CAUTION: Flush the hoses as follows to prevent damage to the attachment hydraulic components.

- 5 Connect hoses to the truck junction block/hose terminal kits or internal reeving fittings. Connect the hoses together using union fittings. Start the truck and actuate the truck control valves in both directions for about 30 seconds to carry any debris left in the hoses to the truck hydraulic tank and filter.

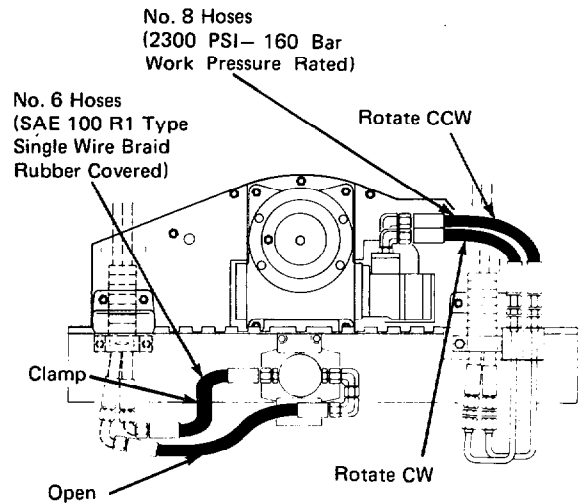

Installation using right and left hand 2-Port THINLINE™ Hose Reels.

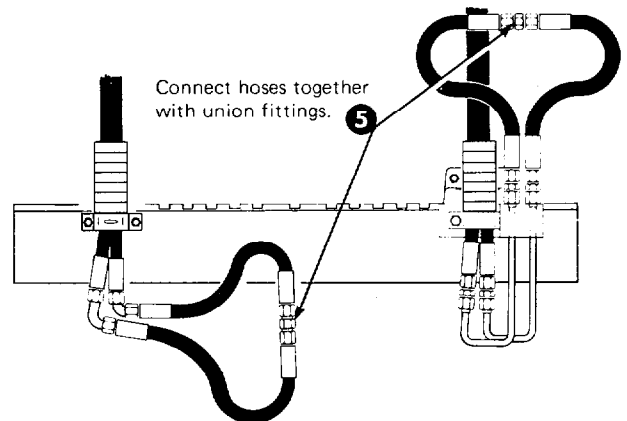

- 6 Remove the union fittings and disconnect hoses from the junction block/hose terminal kits. Connect hoses to the attachment fittings.
- 7 Center the lift truck behind the attachment. Engage the upper mounting hook tab with the closest upper carriage bar notch and raise the truck carriage into position behind the attachment. Lift the attachment 2 in. (5cm) off the pallet.



WARNING: The mounting hooks must be properly engaged with upper carriage bar. The tab on the left mounting hook must be engaged in the mating notch on the upper carriage bar.

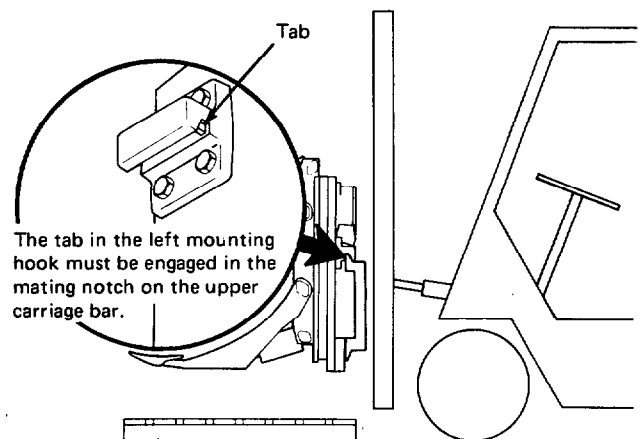

- 8 Install the lower mounting hooks. Tighten the cap-screws finger tight. Tap the end of the mounting hooks with a hammer in the direction of the adjustment arrow for maximum engagement with the lower carriage bar. Tighten the capscrews to a torque of:

55D - 105–115 ft.-lbs. (140–155 N·m)
100D - 180–200 ft.-lbs. (250–270 N·m)

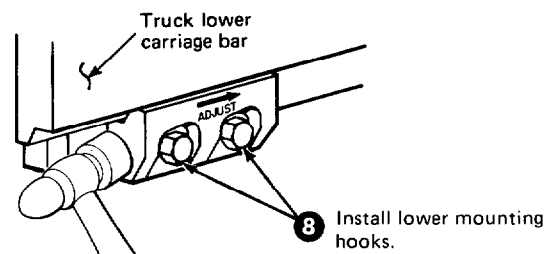

B. Installation (Continued)

- 9 Connect the hydraulic hoses to the junction block/hose terminal fittings. See the chart in Requirements Section for correct auxiliary valve and attachment function operation.

- 10 Install Stop Block Kit 669345 to prevent the attachment from shifting or sliding on the truck carriage. Position each stop block on the truck carriage upper crossbar approximately 1/16 in. (1.5mm) from the outward side of each upper mounting hook. If the carriage bar is not wide enough, place the stop blocks on the inward side of the hooks.

Preheat the carriage upper crossbar weld area and stop block to 400° F. (200°C).

CAUTION: Protect all hydraulic hoses and components from excess heat and weld splatter.

Use AWS E7018 low hydrogen rod and weld a 1/4 in. (6mm) fillet as shown. Let the weld slow cool.

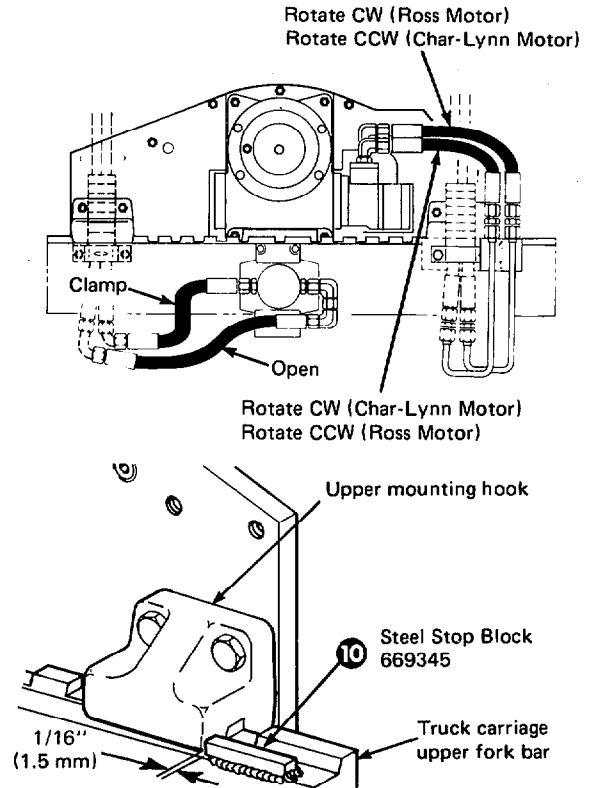

C. Prior To Operation

1. Check for external leaks at the fittings and cylinder rod ends.
2. Before picking up a load, operate the clamp through several cycles to force any air from the system to the truck hydraulic tank.

- Rotate the clamp in both directions.

CAUTION: The clamp must be raised high enough to avoid hitting the arms on the floor during rotation.

- Position the clamp arms in the horizontal and vertical positions. Cycle the long arm in and out several times.

NOTE: Only the long arm will move in these positions. The short arm will stay stationary.

- Position the clamp in any 45° position. Cycle the short arm in and out several times.

NOTE: Only the short arm will move in the 45° position. The long arm will stay stationary.

3. Clamp and rotate a maximum load. If the attachment is sluggish or does not rotate smoothly, recheck the plumbing.
4. The auxiliary valve must actuate the clamp function as shown in the chart in the Requirements Section. If the functions are backwards from the requirements, switch the hoses at the hose reel mounting block or auxiliary valve fittings.



WARNING: Make sure there are no people in the vicinity of the attachment when picking up a load.

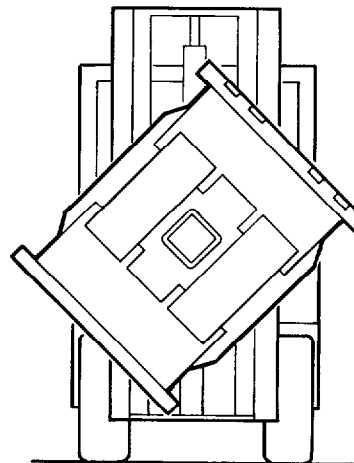

Clamp positioned at 45° for short arm positioning

NOTE: Short arm moves in this position only.

