



Technical Bulletin

Slip-On Drum Arm Groups 656086, 656087, 656088 656089 and 656090 Installation Instructions

This Technical Bulletin describes procedures to install Cascade Slip-On 2 and 4 Drum Arms.

1. Remove the keeper pins from the arm holes. Slip the drum arms onto the forks. Position the drum arm holes at dimension **A** from the fork tips.

<u>Attachment Model</u>	<u>Dimension A</u>
C2, 25D	13 in.
C3, 35D	13 in.
C4, 50D	17 in.

2. Mark the location of the keeper pin holes on the forks. Remove the drum arms from the forks.
3. Drill a hole(s) in the forks using a magnetic base drill. The hole requirements are as follows:

<u>Attachment Model</u>	<u>Hole Size</u>
C2, C3, 25D, 35D	9/16 in. Dia.
C4, 50D	1 in. Dia.

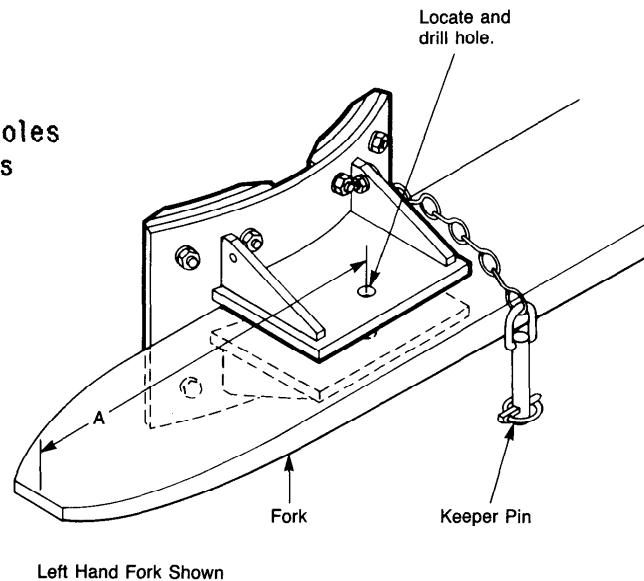

4. Slip the drum arms onto the forks and install the keeper pins.

Part No. 675518

cascade[®] corporation

For Technical Assistance . . .

Call: 1-800-CASCADE or 503-666-1518
 OR
 Write: Cascade Corporation, P.O. Box 20187, Portland, OR 97220

To Order Parts . . .

Call: 513-322-1199
 OR
 Write: Cascade Corporation, P.O. Box 360 Springfield, OH 45505