

# **I** **INSTALLATION INSTRUCTION**

---

## ***F-Series***

### ***90FX Swing Frame Paper Roll Clamp***

***Internal Combustion  
Trucks***

***Manual Number 6006126 R-1***

**cascade<sup>®</sup>  
corporation**

Cascade is a Registered Trademark of Cascade Corporation

# C ONTENTS

Recommended Hydraulic Supply	i
Truck Requirements	1
Installation	2
Periodic Maintenance	11

This Manual provides instructions for installing the Cascade 90FX-Series Paper Roll Clamp on lift trucks.

Follow the suggested installation procedures for best results. If you have any questions or need more information, contact your nearest Cascade Service Department (see back cover).

Read the **WARNING** Statements placed throughout this Manual to emphasize safety during installation.

**IMPORTANT:** Field alterations may impair performance or capability and could result in loss of warranty. Consult Cascade for any required modifications.

## R ECOMMENDED HYDRAULIC SUPPLY

The 90FX Swing Frame Paper Roll Clamp requires two (2) hydraulic circuits over the mast to provide three (3) functions on the Attachment. No solenoid adaption is required. Recommended hydraulic supply arrangement is **A and B**, or **C**. Refer to *Cascade Hose and Cable Reel Selection Guide*, Part No. 212199, to select the correct hose reel for the mast and truck. Hose and fitting requirements are:

- No. 8 with 13/32 in. (10 mm) minimum I.D. for both CLAMP and ROTATE/SWING functions.

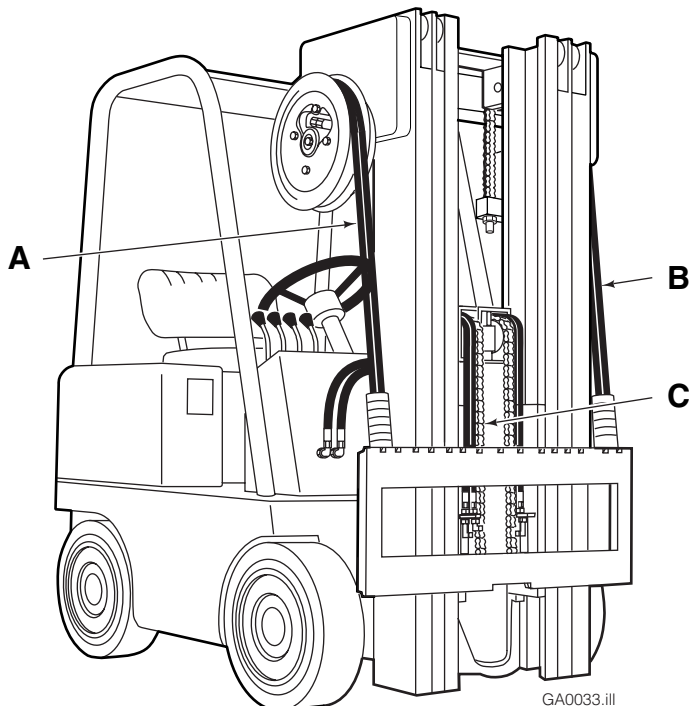

GA0033.iii

### **A and B**

RH and LH THINLINE™ 2-Port Hose Reel Groups.

### **OR**

### **C**

Mast Double Internal Hose Reeving Group.

### **OR (optional)**

### **A or B and C**

LH or RH THINLINE™ 2-Port Hose Reel Group and Mast Single Internal Hose Reeving Group.

# T RUCK REQUIREMENTS

**WARNING:** Rated capacity of the truck/attachment combination is a responsibility of the original truck manufacturer and may be less than that shown on the attachment nameplate. Consult the truck nameplate.

### Truck Relief Setting

2000 psi (140 bar) Recommended  
2300 psi (160 bar) Maximum

### Truck Flow Volume <sup>①</sup>

	Min. <sup>②</sup>	Recommended	Max. <sup>③</sup>
<b>90FX</b>	12 GPM (45 L/min.)	15 GPM (56 L/min.)	20 GPM (75 L/min.)

① Cascade Roll Clamps are compatible with SAE 10W petroleum base hydraulic fluid meeting Mil. Spec. MIL-0-5606 or MIL-0-2104B. Use of synthetic or aqueous base hydraulic fluid is not recommended. If fire resistant hydraulic fluid is required, special seals must be used. Contact Cascade.

② Flow less than minimum will result in a rotate speed less than 2 RPM.

③ Flow greater than maximum can result in excessive heating, reduced system performance and short hydraulic system life.

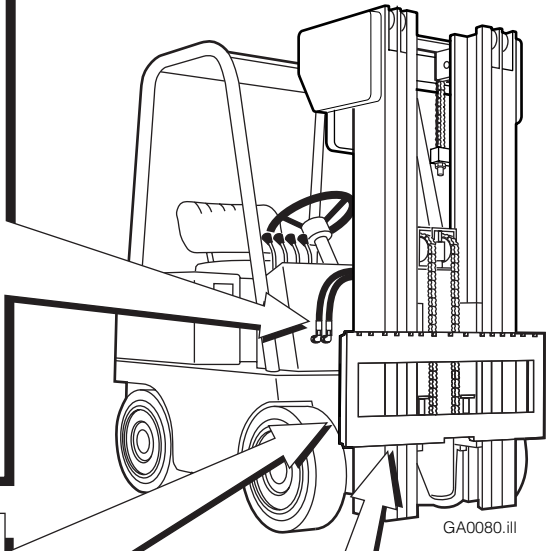

### Carriage Mount Dimension (A) ITA (ISO)

	Minimum	Maximum
<b>Class III</b>	18.68 in. (474.5 mm)	18.74 in. (476.0 mm)
<b>Class IV</b>	23.44 in. (595.5 mm)	23.50 in. (597.0 mm)

GA0028.ill

**Carriage**  
Clean and inspect carriage bars for damage and smoothness. Repair any protruding welds or damaged notches.

## Auxiliary Valve Functions

Check for compliance with ITA (ISO) standards:

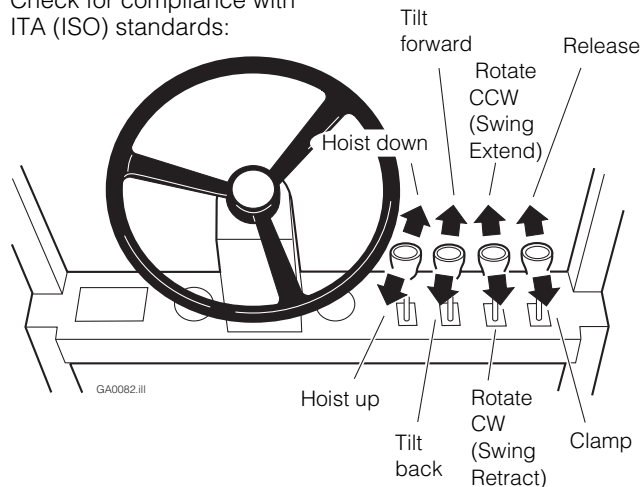

## Truck Preparation

**NOTE:** Prior to installing the 90FX Paper Roll Clamp, install the following components on the truck:

- Priority flow valve in the truck main hydraulic supply line to the truck valve.
- Solenoid-operated 3N2 control valve in the CLAMP supply line to the Attachment.
- Pushbutton switch on the ROTATE control lever.
- 'Tee' adapter in the truck tank main return line for return-to-tank from the 3N2 Control Valve.

### 1 Install Priority Flow Valve

**A** Determine a suitable location and install the priority flow valve in the truck main hydraulic supply line to the truck valve.

**CAUTION:** Make sure priority flow valve is installed downstream of any other truck priority flow valves that may be used for steering and/or brakes.

**B** Connect supply hoses at priority flow valve and truck valve block. Secure with cable ties as required.

**CAUTION:** Do not start truck with PRIORITY/Port 3 capped in the priority flow circuit. Damage to truck pump could result.

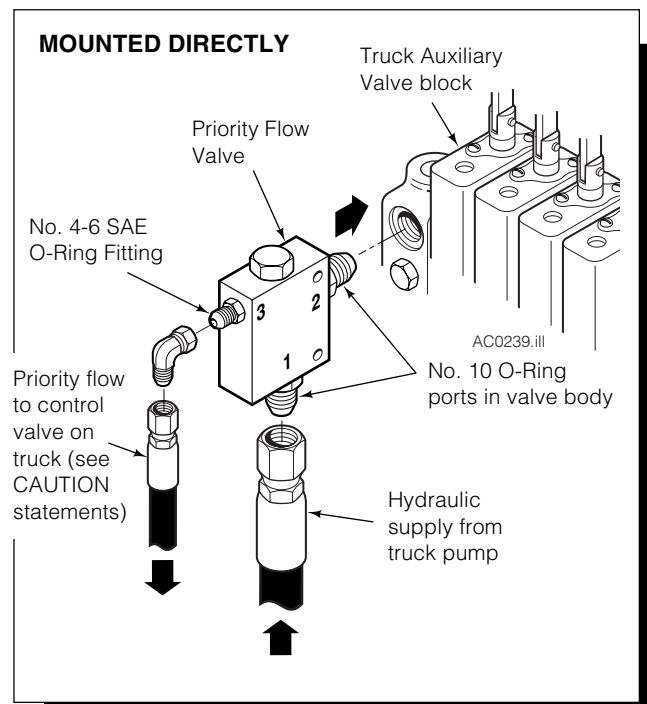

### 2 Install 'Tee' adapter.

**A** Determine a suitable location and install the 'tee' adapter in the truck tank main return line.

**CAUTION:** Do not install into power steering or other tank return lines.

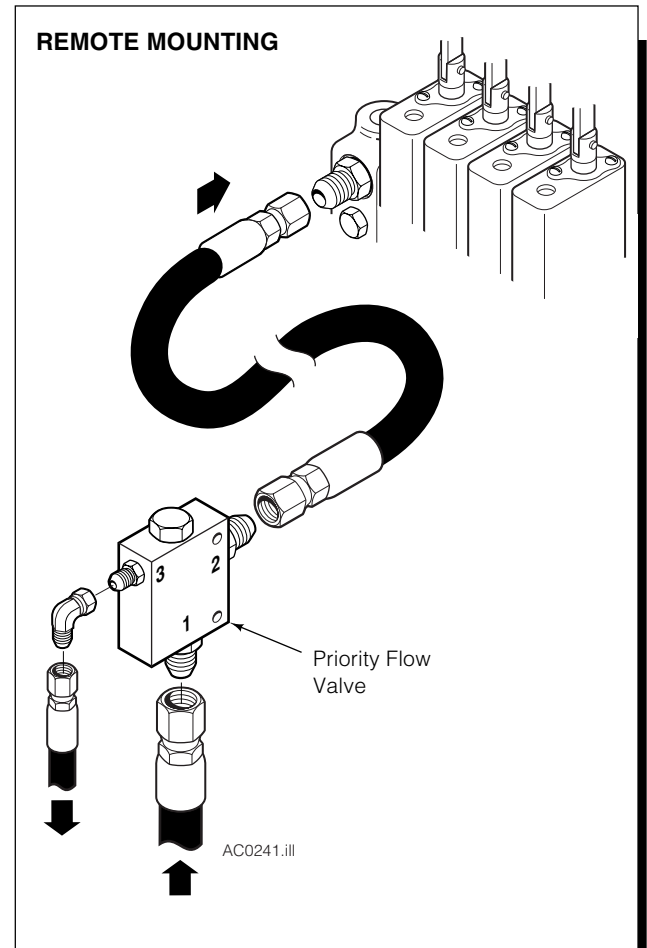
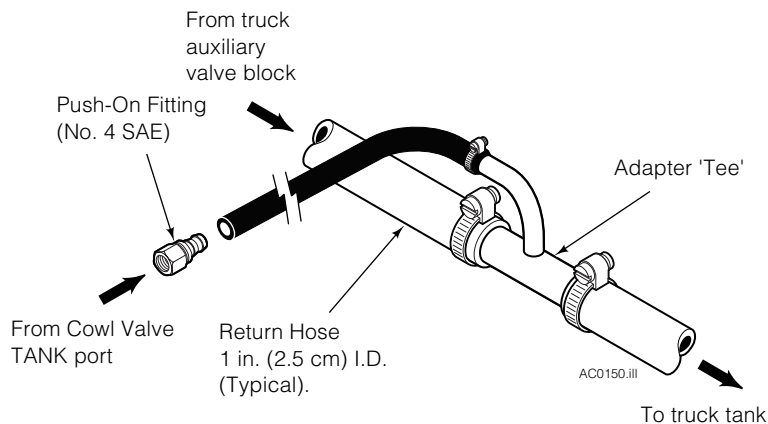

## 3 Install 3N2 Control Valve

**A** Determine a suitable mounting location for the control valve. If mounted on the truck cowl (shown), valve must not extend outside the width of the cowl or interfere with the truck mast when tilted back (see illustration).

If mounted in the engine compartment, make sure valve is securely mounted. Use hose clamps or cable ties as necessary.

**NOTE:** Control valve ports are drilled straight-through, allowing 'tee' connections when opposite ports are capped. Straight-through connections are preferred to reduce entrapped air and enable use of straight fittings.

**B** Install a No. 4 hose (user-supplied) from the cowl valve TANK port to the tank return adapter installed in Step 2.

**C** Install a No. 4 hose (user-supplied) from the cowl valve IN port to the priority flow control valve installed in Step 1. Use straight fittings wherever possible. Use hose clamps as necessary to secure the hoses.

**NOTE:** Revolving Connection end block may have LH or RH Porting for the CLAMP and ROTATE/SWING circuits (LH CLAMP circuit shown below).

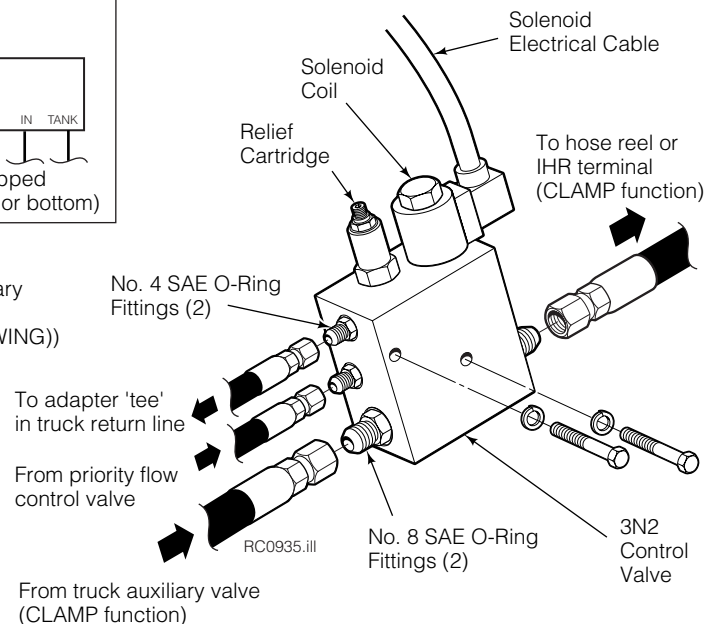
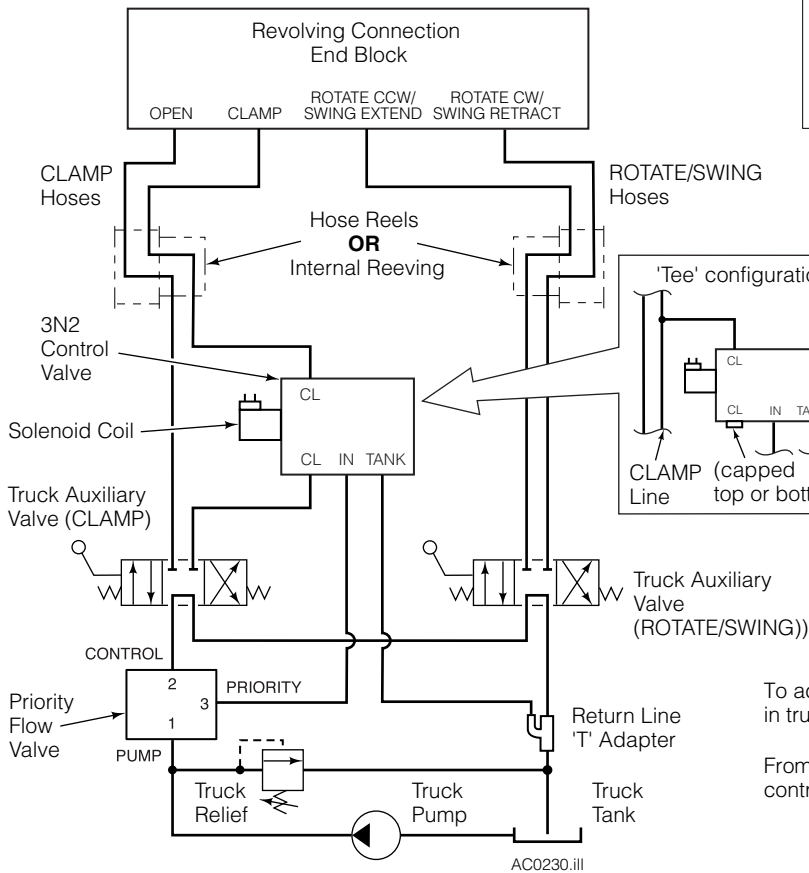
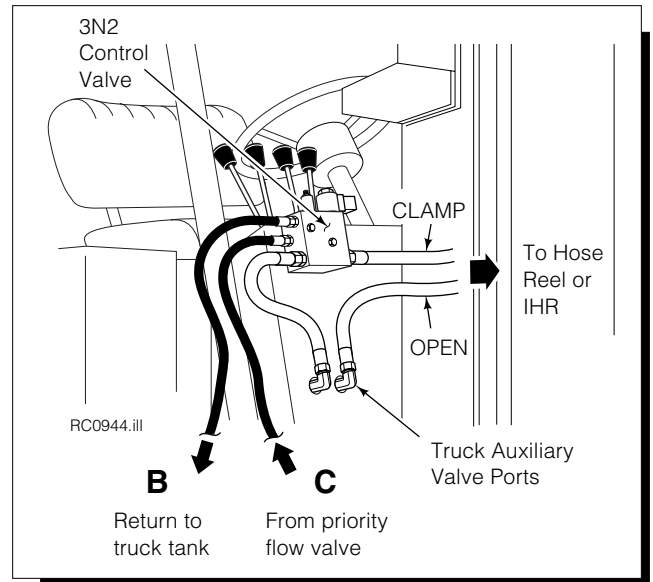
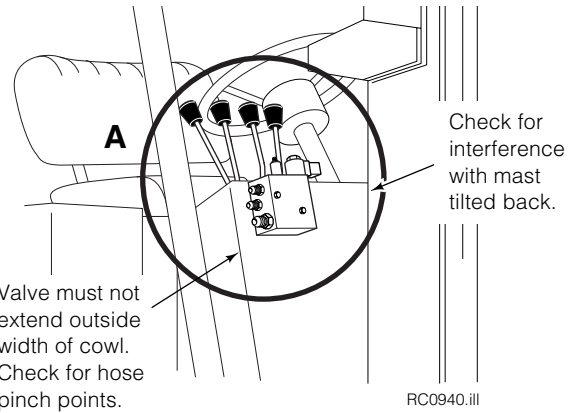

## 4 Prepare Hoses for LH 2-Port Hose Reel or Internal Reeving

**Clamp Function** – Measure and assemble three hoses (user-supplied) as follows:

OPEN function hose runs from truck auxiliary valve port to **LH hose reel or internal reeving**.

CLAMP function hoses run from truck auxiliary valve port to either of cowl valve's CL ports, then from other CL port to **LH hose reel or internal reeving**.

Install hoses using straight fittings wherever possible. Use hose clamps as necessary to secure hoses and prevent chafing.

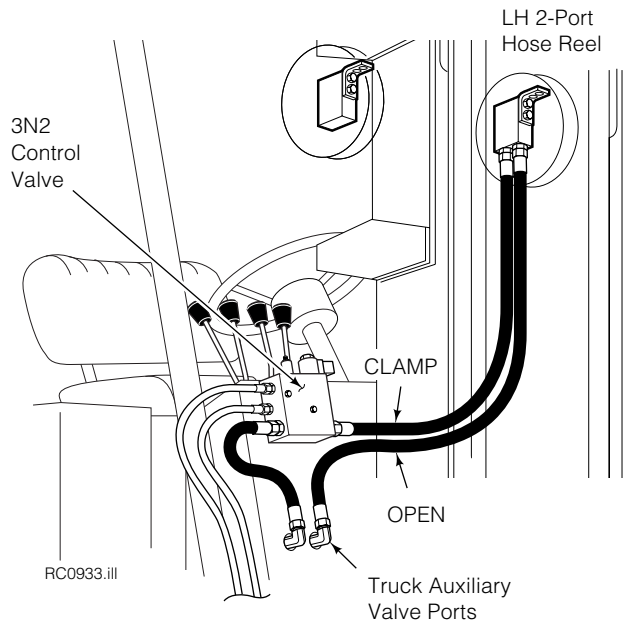

## 5 Prepare Hoses for RH Hose Reel or Internal Reeving

**Rotate/Swing Function** – Measure and assemble two hoses (user-supplied) as follows:

ROTATE/SWING function hoses run from truck auxiliary valve ports to **RH hose reel or internal reeving**.

Install hoses using straight fittings wherever possible. Use hose clamps as necessary to secure hoses and prevent chafing.

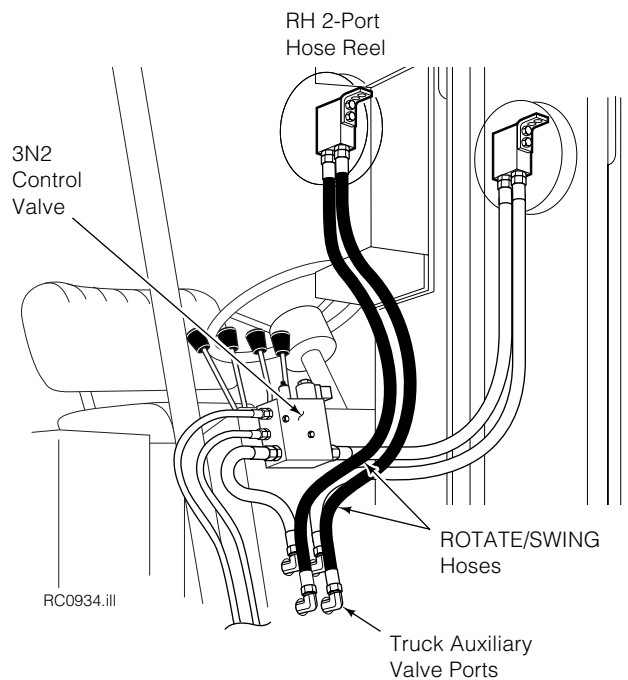

## 6 Install pushbutton switch for SWING function

- A** Mount the pushbutton switch on the ROTATE function control lever using double-sided foam tape. Apply heat-shrink tubing over control lever and switch. Use cable ties as necessary to secure wiring.
- B With Power Relay** – Connect the wiring harness and cables as shown in **B** below.
- C Direct connection** – Connect the wiring harness and cables as shown in **C** below.

**IMPORTANT:** Pushbutton should be installed on ROTATE function lever (ITA Standards). When pushbutton is depressed, control lever should activate SWING function.

**CAUTION:** Consult OEM for proper positive (+) power source connection.

### CONTROL LEVER with PUSHBUTTON SWITCH

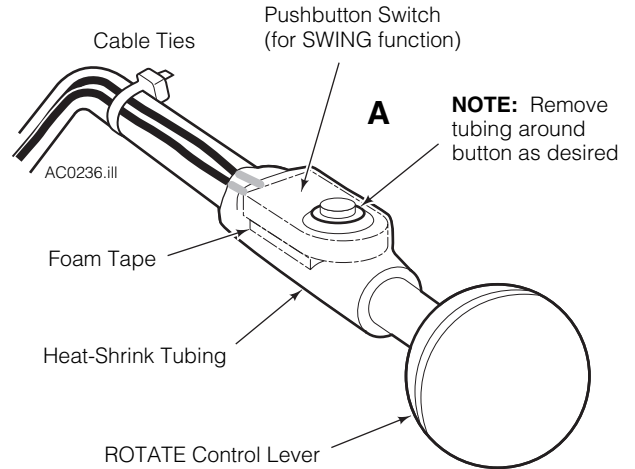

### B ELECTRICAL HOOKUP WITH RELAY (recommended)

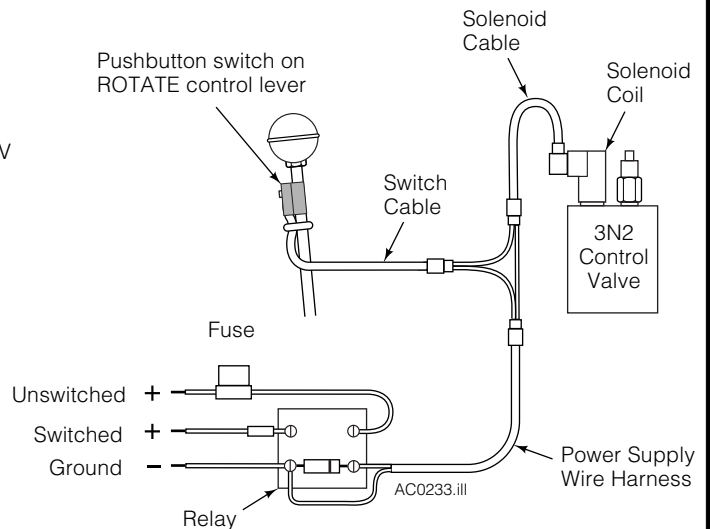
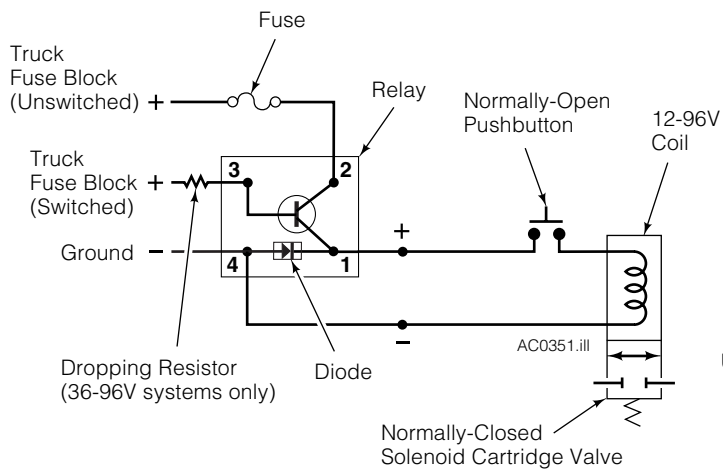

### C DIRECT CONNECTION

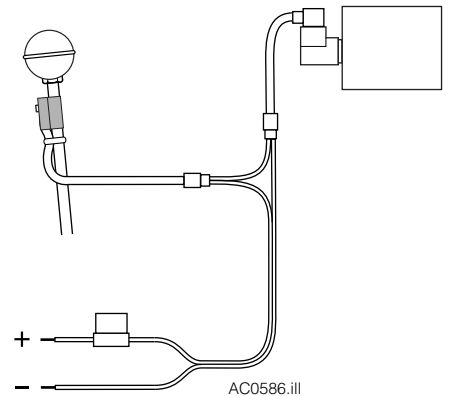
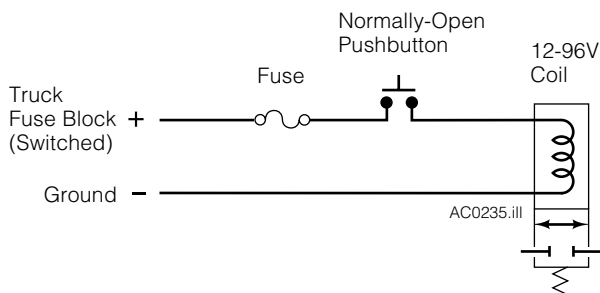

## Clamp Installation

**1 Attach overhead hoist**

**A** Remove banding, set Roll Clamp upright on pallet.

**B** Remove bolt-on lower mounting hooks.

**WARNING:** Make sure overhead hoist and related components have a rated capacity of at least 3500 lbs. (1600 kg).

RC0938.ill

## 2 Remove lower mounting hooks

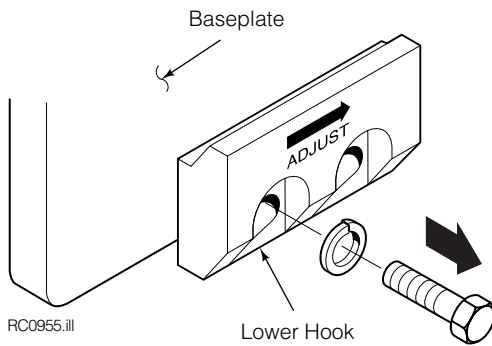

## 3 Prepare Hoses or install Hose Kits

- A** Position truck carriage behind Roll Clamp.
- B** Determine hose lengths required.
- C** Cut hoses to length, install end fittings.

**CAUTION:** Hoses should be 2300-psi working-pressure rated for all Attachment functions. No. 8 hose is recommended for all functions.

**NOTE:** Revolving Connection end block may have either LH or RH porting for the CLAMP and ROTATE/SWING circuits (LH CLAMP circuits shown in the following illustrations).

### INSTALLATION USING RH & LH 2-PORT THINLINE™ HOSE REELS:

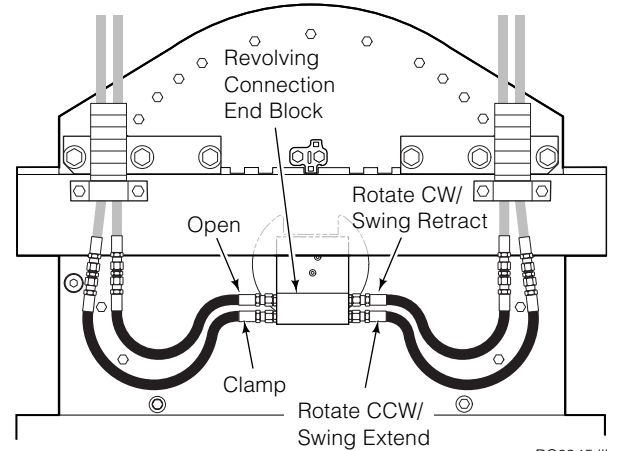

### INSTALLATION USING RH 2-PORT THINLINE™ HOSE REEL AND SINGLE INTERNAL HOSE REEVING:

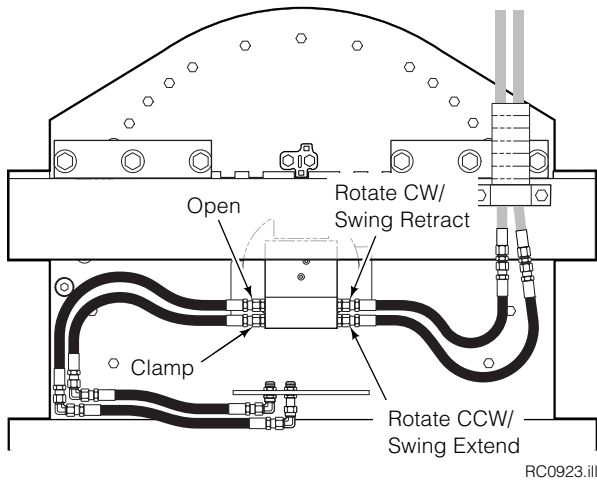

### INSTALLATION USING DOUBLE INTERNAL HOSE REEVING:

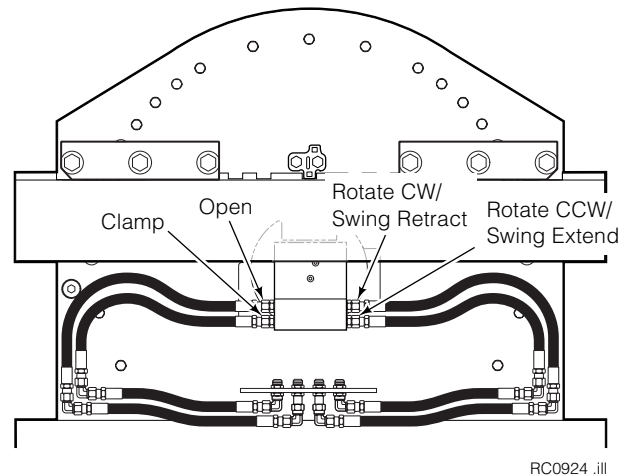

## 4 Flush hydraulic supply hoses

- A** Connect hoses together using union fittings as shown.
- B** Operate auxiliary valves for 40 sec.
- C** Remove hoses and union fittings.
- D IMPORTANT:** Connect hoses to Roll Clamp revolving connection end block fittings as shown in Step 3 above.

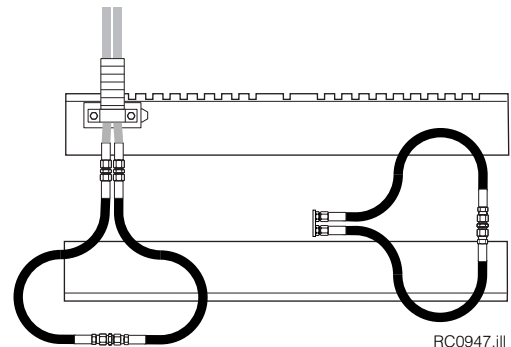

## 5 Mount Clamp on truck carriage

- A** Center truck behind Roll Clamp.
- B** Tilt forward and raise carriage into position.
- C** Engage top mounting hooks with carriage. Make sure centering tab engages a notch on the top carriage bar. **NOTE:** Centering tab can be oriented in 4 different positions to center the Clamp (see illustration).
- D** Lift Clamp 2 in. (5 cm) off pallet.

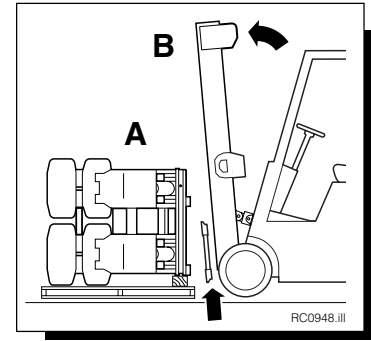

ITA Class III – 0.72–0.78 in. (18–20 mm)  
 ITA Class IV – 0.72–0.78 in. (18–20 mm)

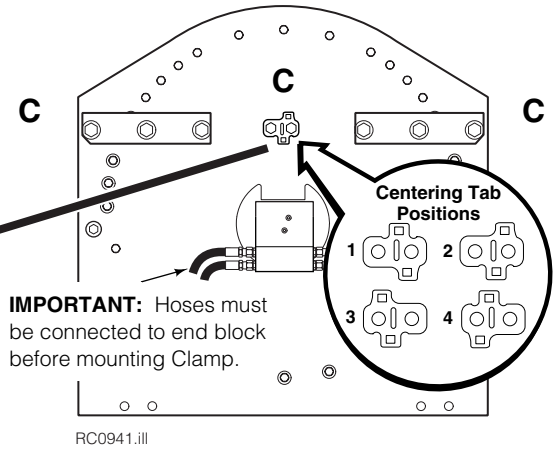
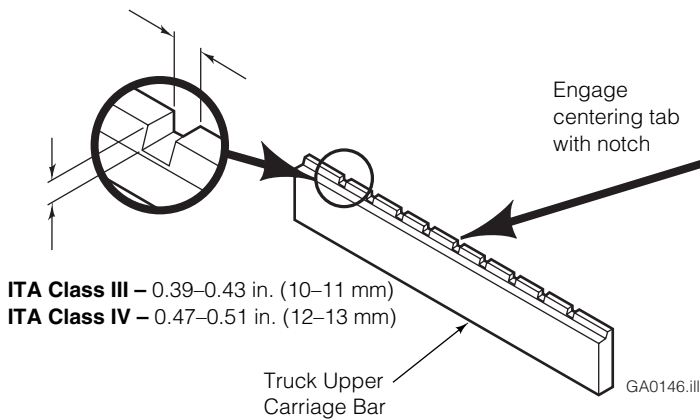

Back (Driver's) View

## 6 Install and engage lower hooks

**BOLT-ON TYPE**

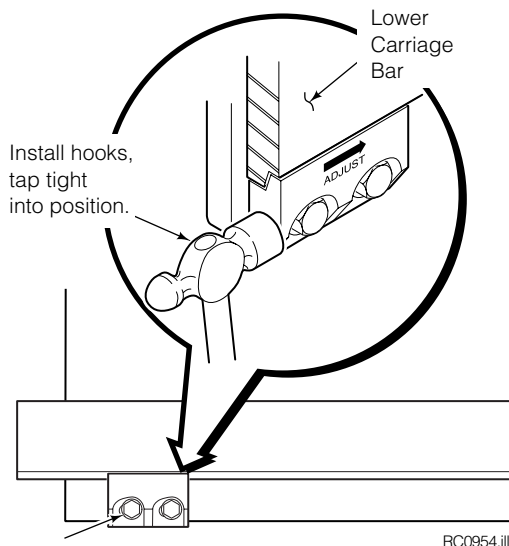

**Class IV: 90FX, 100FX** – Tighten Capscrews to 260 ft.-lbs. (350 Nm)

## 7 Connect hoses prepared in Step 3 to truck supply terminals.

**CAUTION:** Hoses should be 2300-psi working-pressure rated for all Attachment functions. No. 8 hose is recommended for all functions.

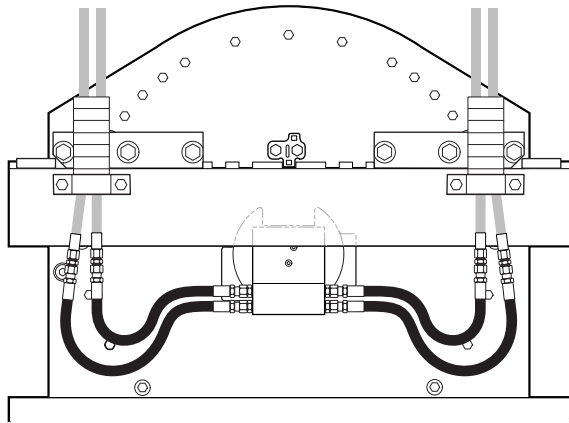

RC0910.ill

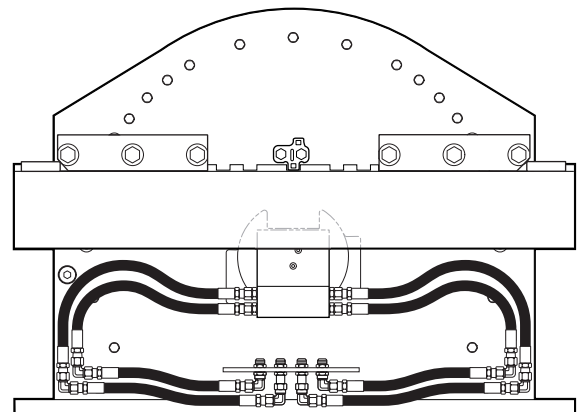

RC0928.ill

## 8 Install stop block kit

- Assure that Clamp is centered on carriage.
- Preheat each stop block and carriage bar weld area to 325° F (180° C).
- Weld a stop block on each end of top carriage bar as shown. Use AWS E7018 low hydrogen rod and weld a 1/4-in. (6 mm) fillet around each stop block.

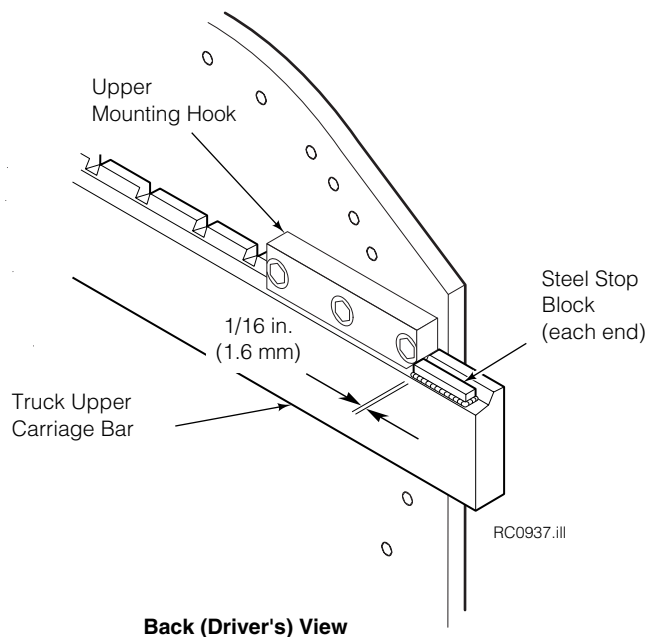

## 9 Purge air from hydraulic system

**IMPORTANT:** All functions must be cycled to remove air trapped in the Attachment hydraulic system before the unit will function properly. Follow the procedure below:

- Cycle long arm several times.
- Rotate to 45 degrees and cycle short arm several times.
- Rotate clockwise (CW) or counter-clockwise (CCW) several revolutions.
- Cycle swing frame several times while Clamp is in vertical roll-handling position.
- Cycle swing frame several times while Clamp is in bilge position.

**NOTE:** If Attachment shifts to swing at any time during the above procedure, actuate the CLAMP lever and resume rotating until air is fully purged.

## 10 Cycle Attachment functions



**WARNING:** Make sure all personnel are clear of the Clamp during testing.

**IMPORTANT:** Make sure hydraulic system is purged of air before checking Attachment functions as outlined below (see Step 9).

- With no load, cycle all functions several times.
- Check functions for operation in accordance with ITA (ISO) standards.
- Clamp and rotate a maximum load, check for smoothness and normal rotation.
- Check for leaks at fittings, revolving connection and cylinder rod ends.

**LONG ARM**  
(vertical & horizontal positions only)

- C** Release
- D** Clamp

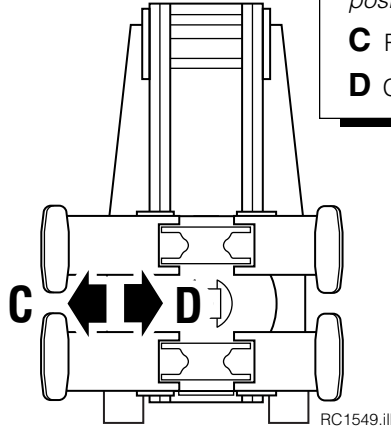

RC1549.iii

**SWING**  
(Bilge handling shown)

- A** (Push button) Extend
- B** (Push button) Retract

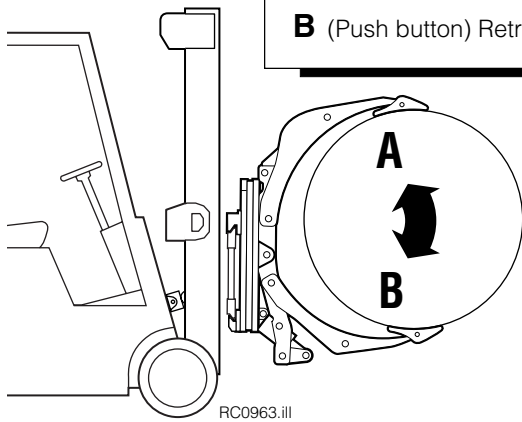

RC0963.iii

**ROTATE**  
(Driver's view)

- A** Counterclockwise (CCW)
- B** Clockwise (CW)

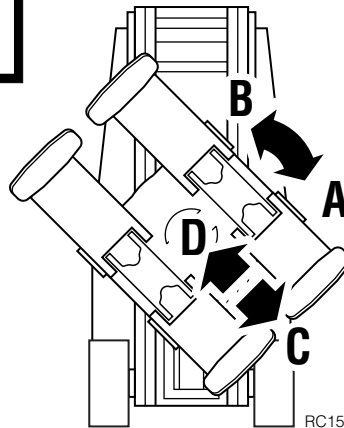

RC1550.iii

**SHORT ARM**  
(45-degree position only)

- C** Open
- D** Close

**NOTE:** Extension or retraction of swing cylinder swings Attachment up or down, left or right, depending on which orientation clamp arms have been rotated to.

### AUXILIARY VALVE FUNCTIONS

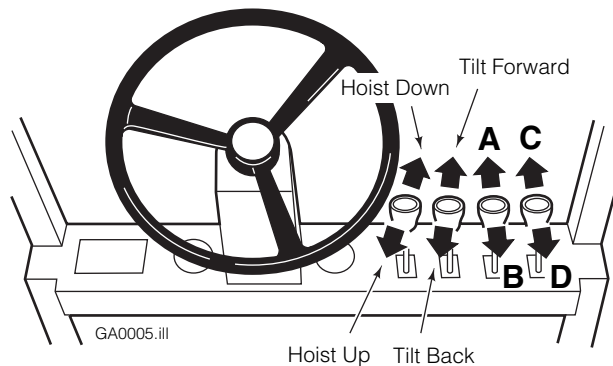

GA0005.iii

## 100-Hour Maintenance

Every time the lift truck is serviced or every 100 hours of truck operation, whichever comes first, complete the following maintenance procedures:

- Check for loose or missing bolts, worn or damaged hoses and hydraulic leaks.
- Check edges of contact pads for wear or sharp nicks that could damage or tear paper rolls. Grind edges smooth.
- Check contact pad pivot joints for wear and replace or repair if necessary (see Service Manual).
- Check that load-holding hydraulic system is functioning properly. Clamp Force Indicators 831887, 830141 and 832442 are available for this test.
- Check decals and nameplate for legibility.

## 500-Hour Maintenance

After each 500 hours of truck operation, in addition to the 100-hour maintenance, perform the following procedures:

- Tighten baseplate-to-bearing assembly capscrews to 75 ft.-lbs. (95 Nm).
- Tighten faceplate-to-bearing assembly capscrews to 75 ft.-lbs. (95 Nm). **NOTE:** Access capscrews through plug in baseplate (see illustration).
- Lubricate rotator bearing assembly with wheel bearing grease. Rotate Clamp in 90-degree increments and grease in each position.
- Tighten all mounting hook capscrews to 260 ft.-lbs. (350 Nm).
- Check rotator drive gearcase lubricant level. Rotate clamp so rotator drive is upright and remove small hex socket plug from top of front cover. Lubricant should run out of hole. If necessary, rotate Clamp 90 degrees and fill with Cascade Rotator Drive Lubricant, Part No. 656300, or SAE 90 wt. gear lube (AGMA 'mild' 6 EP Gear Oil). **CAUTION:** Replace check plug using Loctite 271.
- Inspect all arm and cylinder pivot bearings for wear and replace if necessary (see Service Manual 674512).
- Inspect all load-bearing structural welds on arms, swing frame pivots, arm pivots and cylinder pivot areas for visual cracks. Replace components as required.

## 2000-Hour Maintenance

After each 2000 hours of truck operation, in addition to the 100 and 500-hour maintenance, perform the following procedures:

- Inspect all arm and cylinder pivot pins for wear and replace if necessary (see Service Manual 6028021).



**WARNING:** After completing any service procedure, always test the Clamp through five complete cycles. First test the Clamp empty, then test with a load to make sure the Clamp operates correctly before returning it to the job.

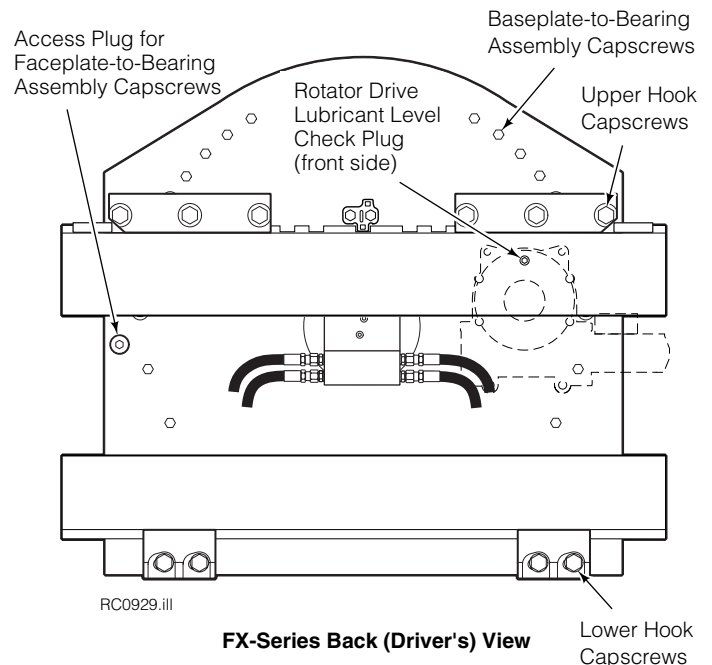
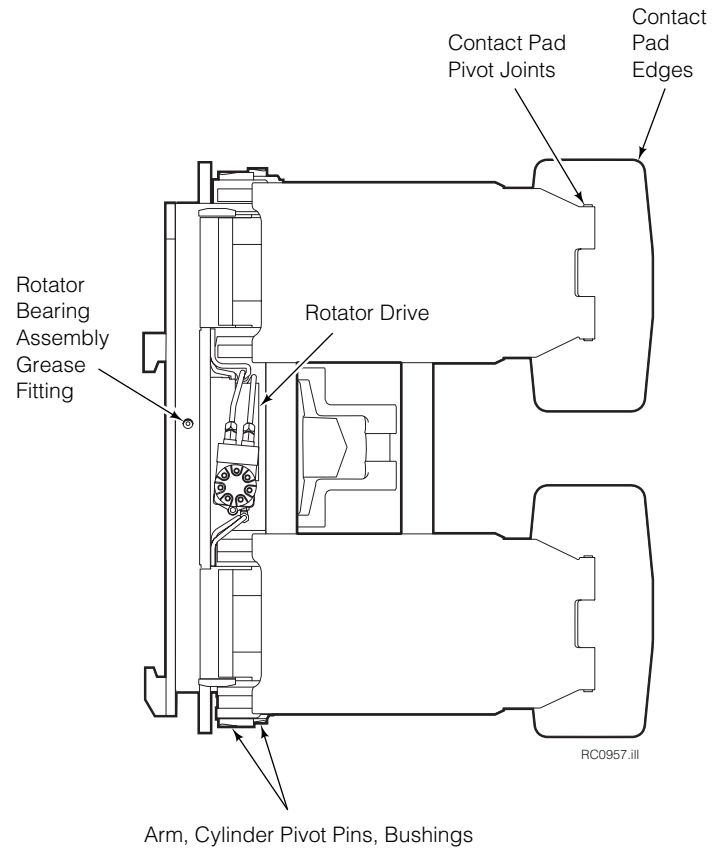

**Do you have questions you need answered right now?** Call your nearest Cascade Service Department. Visit us online at [www.cascorp.com](http://www.cascorp.com)

**Cascade Corporation  
U.S. Headquarters**  
2201 NE 201st  
Fairview, OR 97024-9718  
Tel: 800-CASCADE (227-2233)  
FAX: 888-329-8207

**Cascade Canada Inc.**  
5570 Timberlea Blvd.  
Mississauga, Ontario  
Canada L4W-4M6  
Tel: 905-629-7777  
FAX: 905-629-7785

**Cascade GmbH**  
Dahlener Strasse 570  
41239 Mönchengladbach  
Germany  
Tel: 02166-68230  
FAX: 02166-682323

**Cascade Finland**  
A. Petreliuksenkatu 3  
01370 Vantaa  
Finland  
Tel: 09-8361925  
FAX: 09-8361935

**Cascade N.V.  
Benelux Sales and Service**  
Damsluisweg 56  
PO Box 3009  
1300 El Almere  
The Netherlands  
Tel: 036-5492950  
FAX: 036-5492974

**Cascade (UK) Ltd.**  
Unit 5, Eden Close  
Hellaby Lane Ind. Estate  
Heellaby,  
Rotherham S66 8RW  
England  
Tel: 01709-704500  
FAX: 01709-704501

**Sales Scotland  
Macade Systems Ltd.**  
18 Melford Road  
Righead Ind. Estate  
Bellshill ML4 3LR  
Scotland  
Tel: 01698-845777  
FAX: 01698-845888

**Cascade (Africa) Pty. Ltd.**  
PO Box 625, Isando 1600  
60A Steel Road  
Sparton, Kempton Park  
South Africa  
Tel: 975-9240  
FAX: 394-1147

**Cascade Scandinavia AB**  
Hammarvägen 10  
PO Box 124  
S-56723 Vaggeryd  
Sweden  
Tel: 039-336950  
FAX: 039-336959

**Cascade France  
S.A.R.L. MHP**  
1D Rue De Charaintru  
BP 18,  
91360 Epinay-Sur-Orge  
France  
Tel: 01-6454-7500  
FAX: 01-6454-7501

**Cascade Hispania S.A.**  
Carrer 5, Sector C  
Zona Franca Duanera  
Poligono de la Zona Franca  
08040 Barcelona  
Spain  
Tel: 93-264-07-30  
FAX: 93-264-07-31

**Sales Italy**  
Via Ponzano 11  
50047 Prato  
Italy  
Tel: 0574-571726  
FAX: 0574-571726  
Mobile Phone: 0337-673029

**Sales Portugal FAG  
Santos Lda**  
Rua do Mercado  
Lte 6, Loja 2-Tires  
2785-630  
S. Domingos De Rana  
Portugal  
Tel: 214-448-083  
FAX: 214-458-098

**Sales Switzerland  
Fahrzeugbedarf**  
8810, Horgen  
Switzerland  
Tel: 01-7279797  
FAX: 01-7279798

**Sales Poland**  
Targowa 35/61  
03-728 Warszawa  
Tel: 022-619 00 49  
FAX: 022-619 00 49  
Mobile Phone: 0501-27 29 55

**Sales Russia**  
EMCG Material Handling  
Equipment  
Moscow  
Tel: 095-795-2400  
FAX: 095-795-2475  
Email: [emcg@dol.ru](mailto:emcg@dol.ru)

**Cascade Japan Ltd.**  
5-5-41,  
Torikai Kami  
Settsu, Osaka  
Japan, 566  
Tel: 81-726-53-3490  
FAX: 81-726-53-3497

**Cascade Korea**  
108B Namdong Ind. Complex  
658-3 Gojan-Dong  
Namdong-Gu  
Inchon, 405-310 Korea  
Tel: 82-32-821-2051  
FAX: 82-32-821-2055

**Cascade Australia**  
1445 Ipswich Road  
Rocklea, QLD 4106  
Australia  
Tel: 1-800227-223  
FAX: (07) 3373-7333

**Cascade New Zealand**  
15 Ra Ora Drive  
East Tamaki, Auckland  
New Zealand  
Tel: 9-273-9136  
FAX: 9-273-9137

**Cascade-Xiamen**  
No. 668 Yangguang Rd.  
Xinyang Industrial Zone  
Haicang, Xiamen City  
Fujian Province  
P.R. China 361026  
Tel: 86-592-651-2500  
FAX: 86-592-651-2571

**Cascade (Singapore)  
Trading Co.**  
Four Seasons Park  
Autumn Block - Apt. 1802  
12 Cuscaden Walk  
Singapore  
Tel: 65-834-1935  
FAX: 65-834-1936

