

# **U** *SER MANUAL*

---

## *Hydraulic Force Control*

*LINDE 25-50*

*Manual Number 6099530*

**cascade**<sup>®</sup>  
**corporation**

Cascade is a Registered Trademark of Cascade Corporation

	<b>Page</b>
<b>OVERVIEW</b>	<b>1</b>
<b>INSTALLATION</b>	<b>2</b>
Equalizer Valve and Hoses	<b>2</b>
HFC Valve and Hoses	<b>3</b>
Return-to-Tank & Optional Overdrive Valve	<b>4</b>
Sensor Switch (if equipped)	<b>5</b>
Disabling HFC System	<b>6</b>
<b>PRIOR TO OPERATION</b>	<b>8</b>
<b>OPERATION</b>	<b>9</b>
<b>TROUBLESHOOTING</b>	<b>10</b>
<b>PARTS</b>	<b>12</b>
<b>GLOSSARY</b>	<b>18</b>

## HYDRAULIC FORCE CONTROL (HFC)

This manual provides installation instructions, prior to operation, operation, troubleshooting and parts for Cascade Hydraulic Force Control (HFC) systems. If you need additional information or assistance, contact Cascade Corporation. Refer to the back cover.

### What The System Does

The HFC system enables Cascade Paper Roll Clamps to automatically apply clamp force proportional to weight of the load. This system will reduce the chance of damage caused by excessive clamp force.

### How The System Works

An initial no-slip starting pressure is applied to the load when it is first clamped. As the load is lifted, the HFC system increases clamp force and applies a consistent clamp force proportional to load weight. The hoist system provides pressure to the HFC to increase clamp pressure as hoist pressure increases.

### Prior to Installation

The system can be calibrated to balance the clamp force relationship of clamp capacity and truck size. The truck HOIST pressure should be equal to or higher than clamp pressure to properly clamp paper. Total load weight equals paper weight plus clamp weight.

Confirm that the truck size is compatible with the clamp capacity. Available maximum hoist pressure with load weight (combined maximum size load and weight of the clamp) should be determined in freelif. The hoist pressure determined needs to be within 10% of the clamping pressure required to clamp the heaviest load.

**NOTE:** Kit 6095869 is to be used on trucks with a flow volume greater than 18 GPM (68 L/min.).

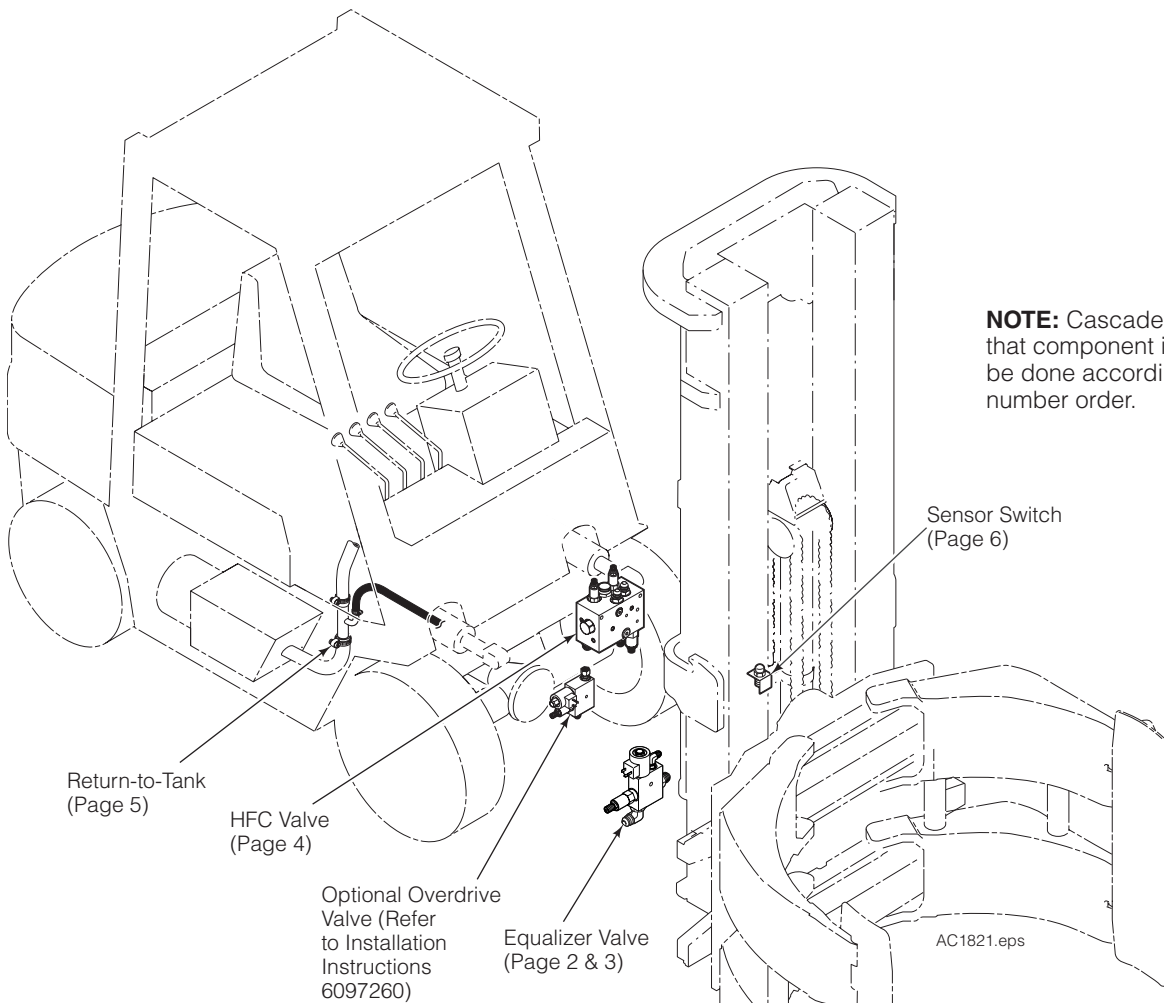

# INSTALLATION

## SOLENOID OPERATED EQUALIZER VALVE AND HOSES



**WARNING:** Before removing hydraulic lines or components, relieve pressure in the hydraulic system. Turn truck off and open the truck auxiliary control valve(s) several times in both directions.

**WARNING:** Follow all recommended safety practices including chaining the freelift mast to the mainlift crossmember when mast is raised.

- 1 Install equalizer mounting assembly to the mast cylinder.
- 2 Install adapter fittings to HFC, TRUCK and MAST ports on the equalizer valve.
- 3 Install the equalizer valve to the mounting assembly.
- 4 Install kit hose from the hoist auxiliary valve HOIST port to the equalizer valve TRUCK port.
- 5 Install the kit hose that connects from the equalizer valve MAST port to the mast lowering control valve.
- 4 Inspect hoses for pinch points and secure as required.

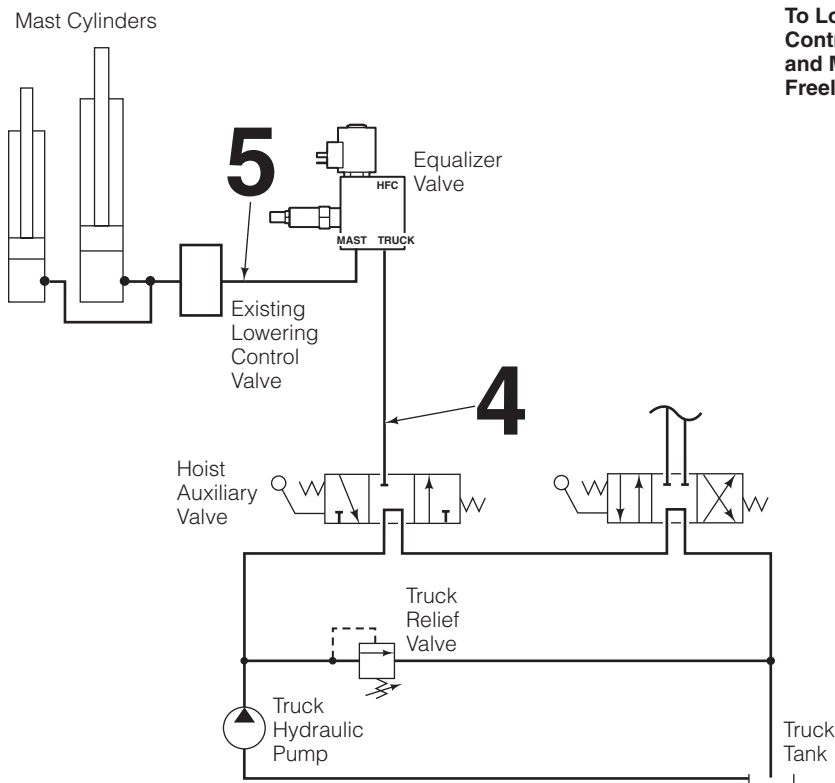
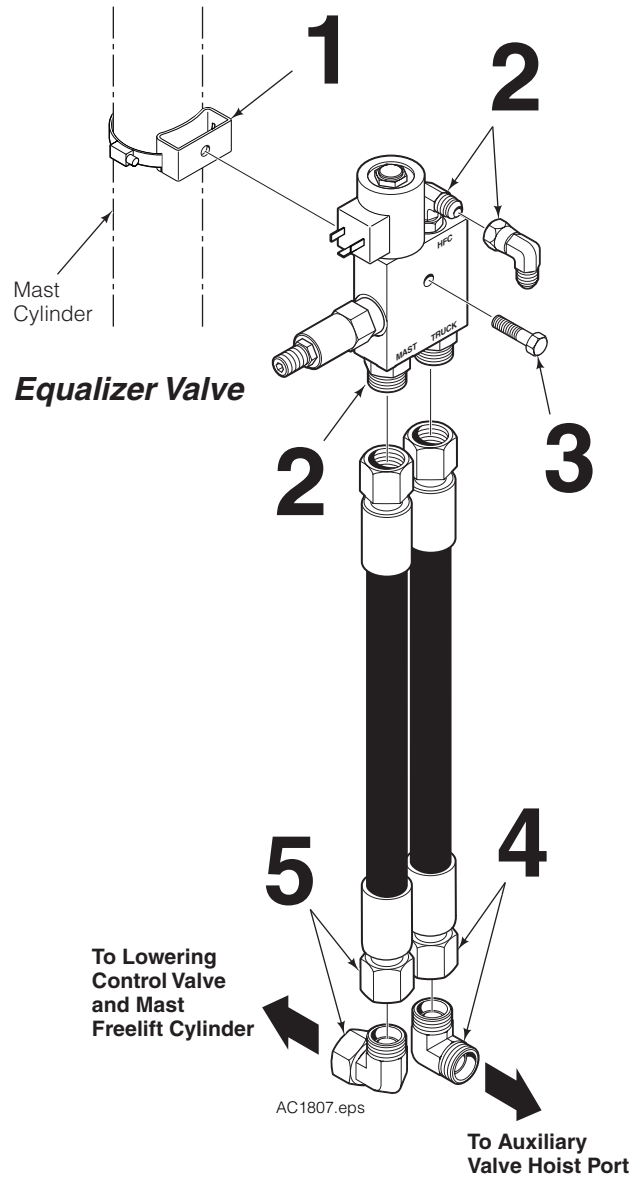

# INSTALLATION

## HFC VALVE AND HOSES

- 1 Install HFC mounting assembly to the mast cylinder.
- 2 Install adapter fittings to T, H, CL2 and OP2 ports on the HFC valve.
- 3 Install the HFC valve to the mounting assembly.
- 4 Remove fitting from CL1 port. Install kit hose and fitting from the truck auxiliary clamp circuit CLAMP port to the CL1 port of the HFC valve.
- 5 Remove fitting from OP1 port. Install kit hose and fitting from the truck auxiliary valve clamp circuit OPEN port to the OP1 port of the HFC valve.
- 6 Install kit hose and fitting from the CL2 port of the HFC valve to the attachment revolving connection CLAMP supply circuit.
- 7 Install kit hose and fitting from the OP2 port of the HFC valve to the attachment revolving connection OPEN port supply circuit.
- 8 Install kit hose from the H port of the HFC valve to the HFC port of the equalizer valve.
- 9 Inspect hoses for pinch points and secure as required.

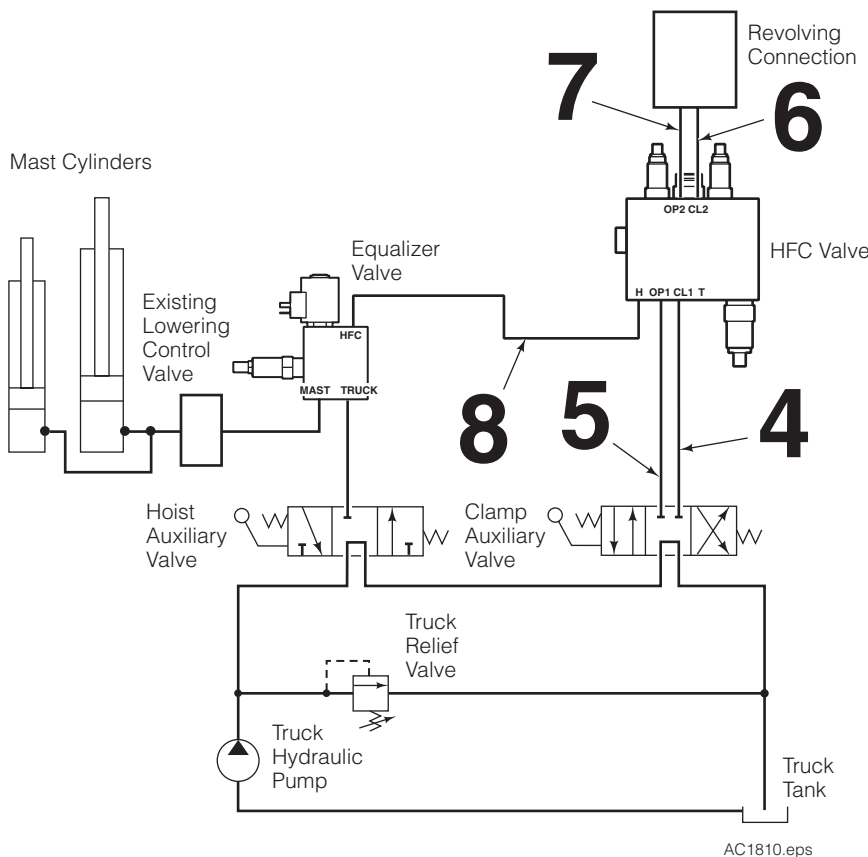
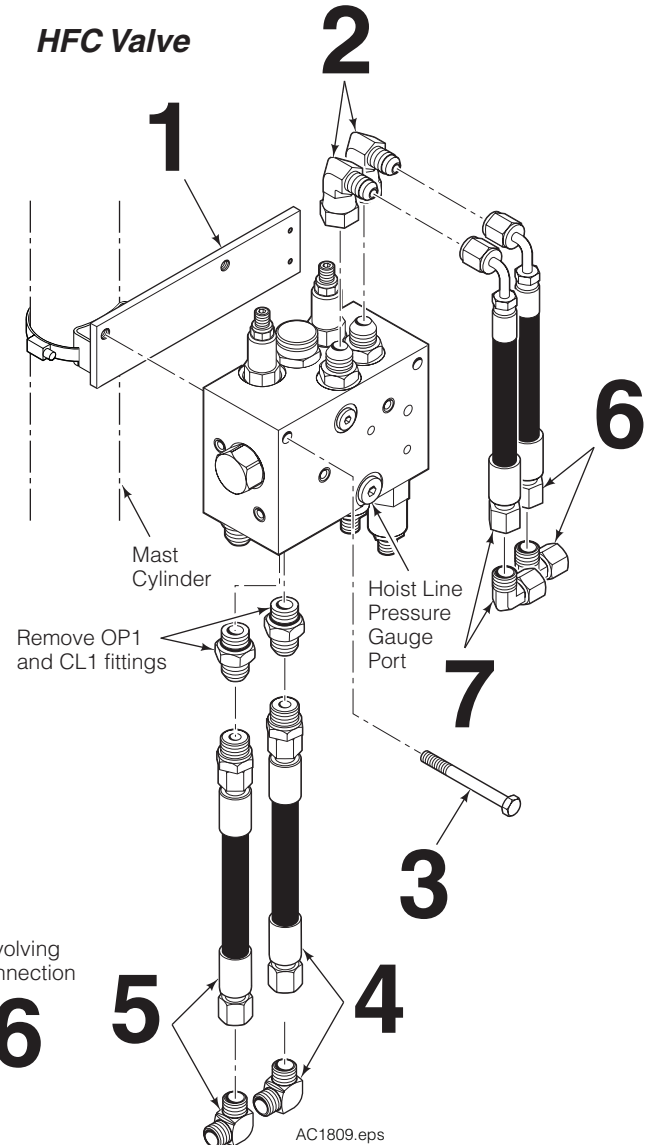

# INSTALLATION

## RETURN-TO-TANK & OPTIONAL OVERDRIVE VALVE

- 1 Install a return-to-tank fitting in the tank line. Lube hose ends and fitting for easy assembly. For complete installation procedure, refer to Installation Instructions 211744 (Kit 6098206).

**NOTE:** For trucks with pressurized return-to-tank lines, the hydraulic tank filler cap must be opened to relieve trapped pressure.

- 2 **No Overdrive Valve** – Connect the T port on the bottom of the HFC Valve to the truck tank line fitting.

**Overdrive Valve** – Connect the overdrive valve T IN port with the HFC valve T port. Connect a hose from the overdrive valve T OUT port to the truck tank line fitting. Refer to installation instructions 6097260 for additional information.

**CAUTION:** If the overdrive valve is not directly installed to the HFC valve T port, a high pressure hose must be used. High pressure hose must be rated for 2300 psi (160 bar) working pressure.

- 3 Inspect hose for pinch points and secure as required.

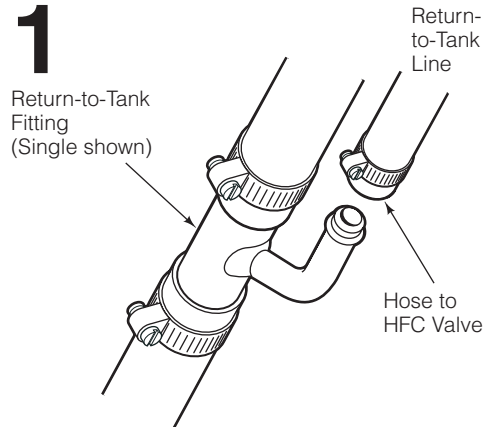

AC0226.eps

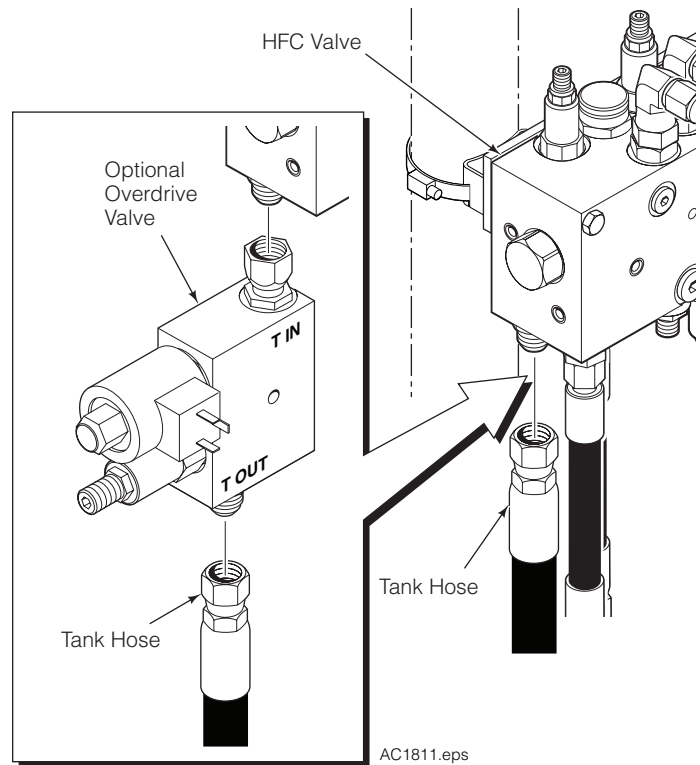

AC1811.eps

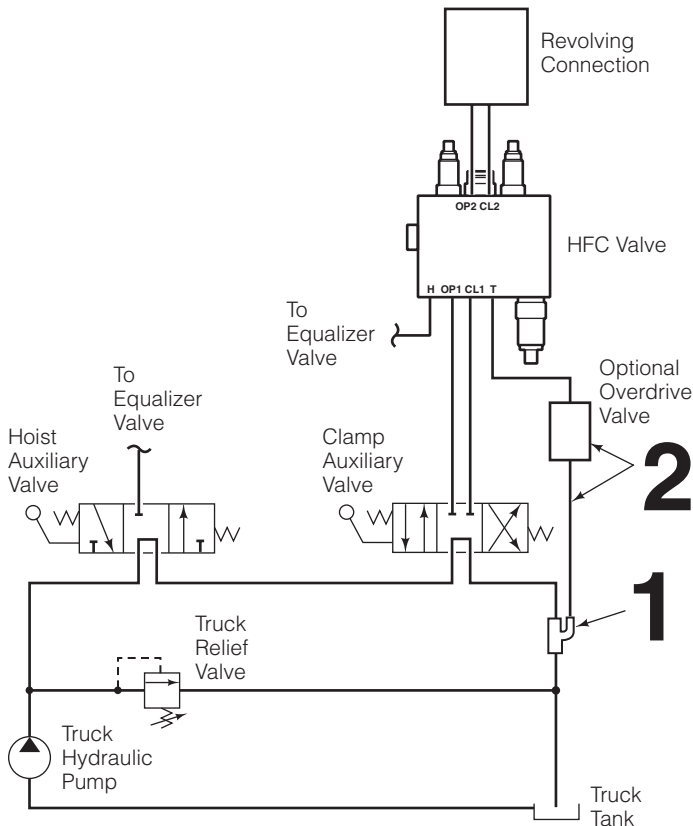

AC1767.eps

# INSTALLATION

## SENSOR SWITCH

- 1 Determine locations to mount the sensor switch on a fixed location on the mast and the bracket with spring wire (if needed) on a moving member on the mast. The sensor switch will signal the mast transition from freelift to mainlift. The provided mounting bracket can be used or modified to aid with mounting the sensor switch.

**CAUTION:** Consult the Lift Truck OEM for proper + power source connection.

- 2 Connect the harness solenoid connector to the solenoid coil.
- 3 Connect the harness sensor switch connector to the sensor switch.
- 4 Connect the harness cable ends to the components shown.

**12V Systems** – Connect the fused positive wire from the cable harness to a switched power source and the ground wire to a chassis ground.

**24V–48V Systems** – Connect the fused positive wire from the cable harness to a DC-to-DC converter positive output wire and the ground wire to the converter negative output wire. Connect a 24V–48V switched power source to the converter fused positive input wire and connect the converter input ground wire to a chassis ground.

**NOTE:** For troubleshooting the wire harness, verify that the sensor switch, solenoid and relay are working properly. Check the LEDs on the sensor switch and solenoid. When the mast is in freelift, the LEDs will illuminate and when in mainlift, the LEDs will be off. Check current flow in and out of relay.

**NOTE:** When installing on the electric trucks with regenerative braking, voltage filter 6061953 must be installed. Failure to install voltage filter can cause damage to electrical components.

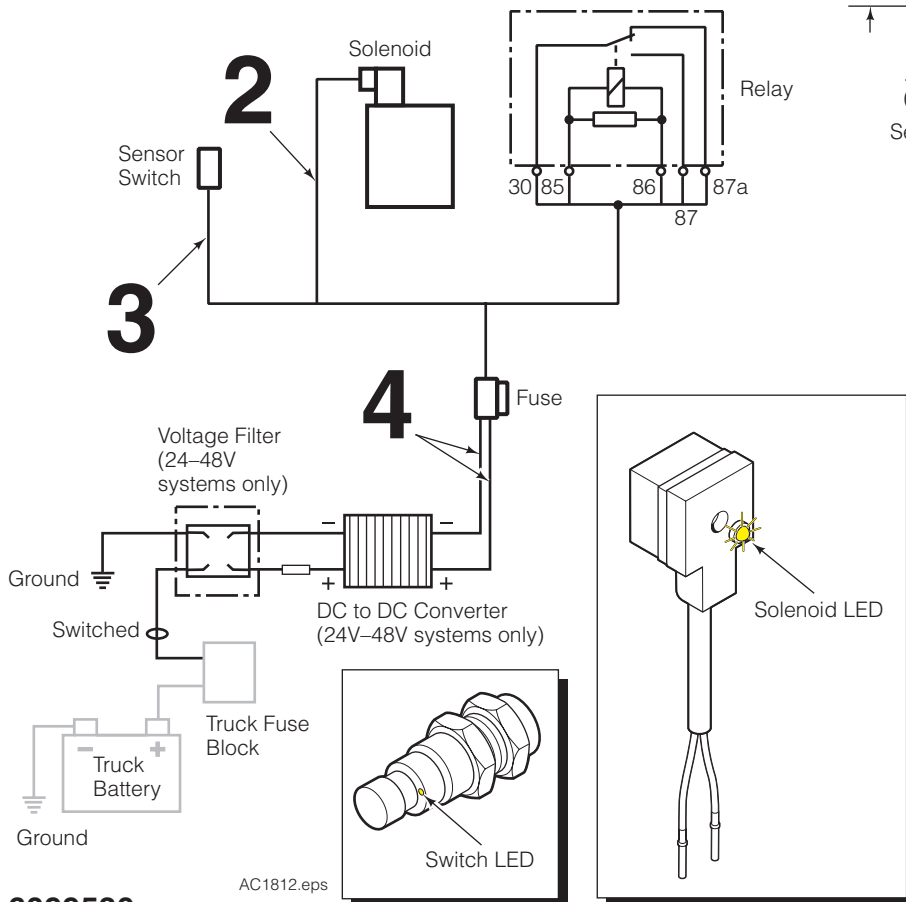
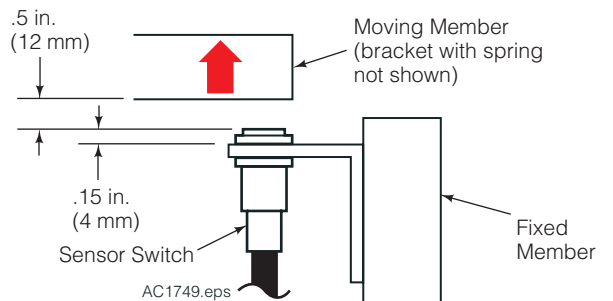
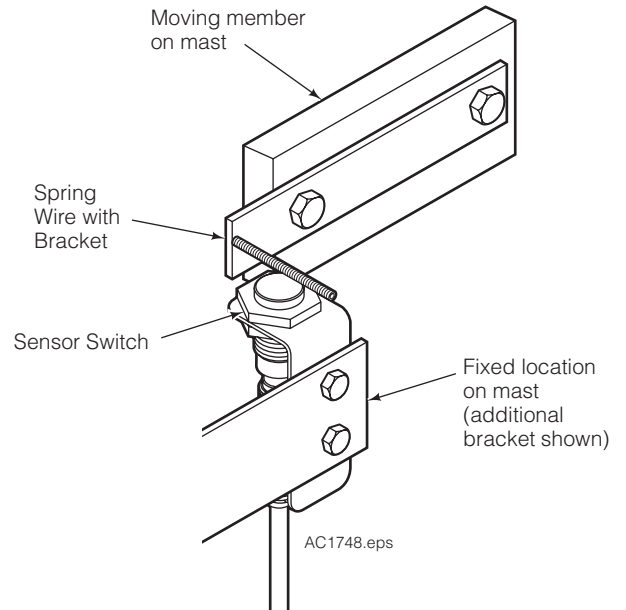

# INSTALLATION

## DISABLING HFC SYSTEM

To temporarily disable the HFC features, perform the following steps:

- 1 Turn V1 inward (CW) or until desired clamp pressure is reached. The maximum pressure that the cartridge is capable of handling is 3000 psi (207 bar).
- 2 Turn V4 all the way out (CCW).
- 3 **OPTIONAL:** If the hoist capacity is affected by lifting a load, turn V5 all the way out (CCW).
- 4 The truck attachment will now operate in the standard mode.

**NOTE:** To enable HFC features refer to Prior To Operation Section.

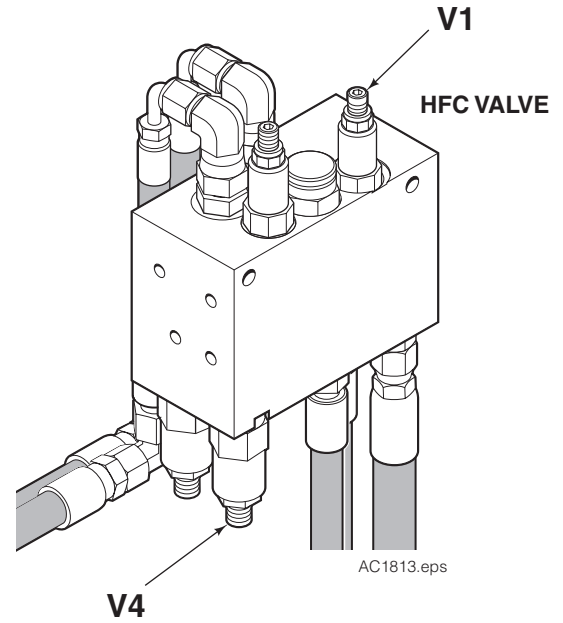
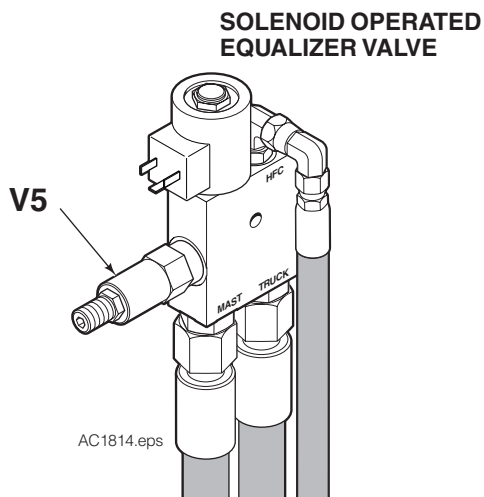

### CARTRIDGE FUNCTION SUMMARY

**Starting Pressure (V1)** – Sets starting pressure.

**Final Pressure (V2)** – Adjusts clamping pressure after hoisting. Must be adjusted **after** all other cartridges are set.

**Static Hoist Pressure (V3)** – Closes connection from hoist line to clamp line.

**Freelift Pressure (V4)** – Limits maximum clamping pressure. Must not be set lower than pressure needed to handle maximum roll.

**Mainlift Pressure (V5)** – Increases freelift hoisting pressure. Balances freelift and mainlift hoisting pressure and make pressure available to clamping circuit.

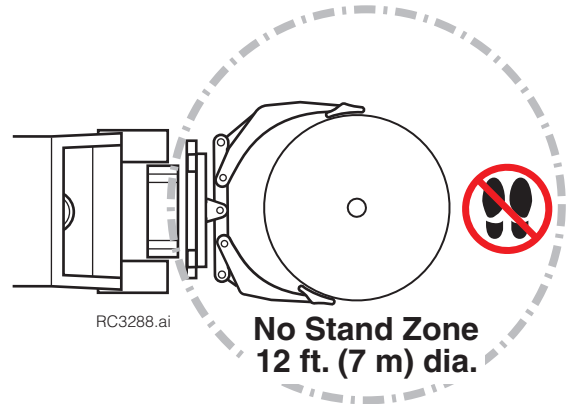

**IMPORTANT:** Check that V2 is completely turned out (counterclockwise) before adjustment process.

- 1 Install the pressure gauge (Cascade Pressure Test Kit 6034612) in the long arm clamp cylinder gauge port.
- 2 Adjust the Starting Pressure (V1) cartridge so that a light load is not damaged or over clamped and the heaviest load does not slip upon hoisting.

**NOTE:** For attachments that are retrofitted with HFC system and lowest pressure is known, use the lowest pressure as starting pressure.

- 3 To prevent carriage/attachment from drifting, adjust the Static Hoist Pressure (V3) cartridge. This pressure must be less than the Starting Pressure (V1).
  - If the maximum weight load slips when hoisting, reduce V3 by turning counterclockwise (CCW).
  - If the carriage lowers when closing the arms of the clamp, increase V3 by turning clockwise (CW).
- 4 To limit the maximum clamp pressure (V4), fully close arms without a load and hoist to maximum lift. Fully extend the mast and hold the lever for 2 seconds. Lower the mast without unclamping and check the pressure. If the pressure exceeds the desired maximum clamp pressure for the heaviest load, turn the cartridge (V4) CCW to decrease the maximum pressure.

Adjusts clamping pressure after hoisting. Adjust this cartridge last.

Sets starting pressure. Must be higher than V3.

**FINAL PRESSURE V2**

**V1 STARTING PRESSURE**

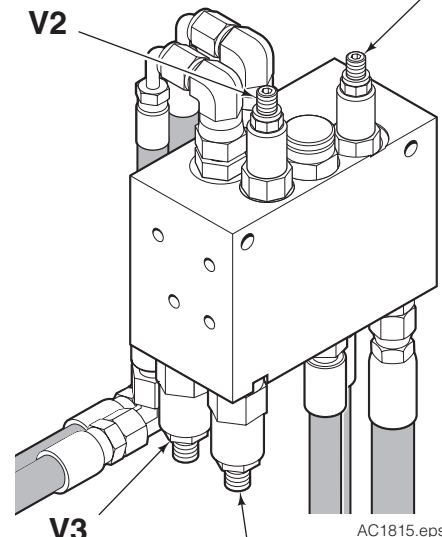

**V3 STATIC HOIST PRESSURE**

**V4 MAXIMUM CLAMP PRESSURE**

Closes connection from hoist line to clamp line. Must be lower than V1.

Limit maximum clamping pressure.

**5** To equalize the hoist pressure between freelif and mainlift, clamp an average load and hoist off the ground about 1 ft (30 cm) (freelif). Record the pressure. With the same load at a higher position (mainlift), clamp the load, hoist the load and lower to the ground without unclamping. Record the pressure.

- If pressure is within 150 psi (10.5 bar), no adjustment is required.
- If mainlift pressure is higher than the freelif pressure, increase V5 by turning CW to equalize pressure.
- If freelif pressure is higher than the mainlift pressure, decrease V5 by turning CCW to equalize pressure.

**6** For non-freelif mast large trucks with small attachments, clamp pressure may need to be increased. The switch should be powered at all times. Clamp a roll and hoist. Note the clamp cylinder pressure.

- If the pressure is less than the desired clamp pressure, increase the pressure by turning V5 in CW to match the desired clamp pressure.

**7** To adjust the Final Pressure (V2), clamp a load. Hoist the load. Use the chart below to record the initial clamp pressure. If the pressure is too high for the heaviest load, turn the cartridge CW to reduce the adjusted clamp pressure. Record the adjusted clamp pressure

ROLL WEIGHT	INITIAL CLAMP PRESSURE ●	ADJUSTED CLAMP PRESSURE ●
#1		
#2		
#3		
#4		
#5		

● Read from long arm clamp cylinder gauge port

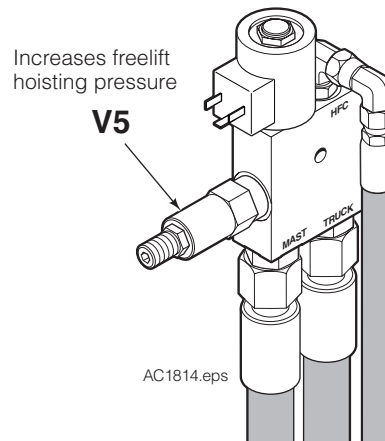

Adjusts clamping pressure after hoisting. Adjust this cartridge last.

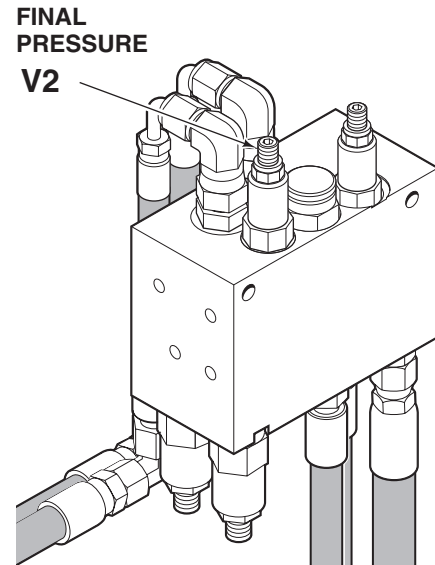

## Auxiliary Valve Functions

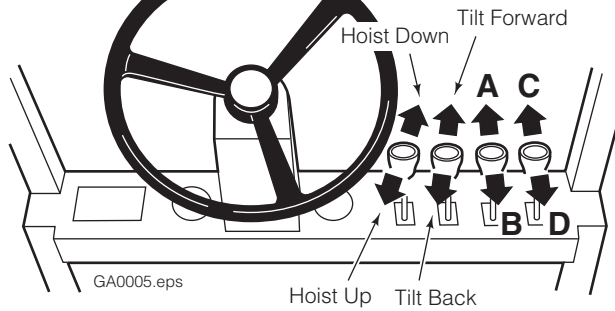

**WARNING:** Truck control handle and attachment function activation shown here conforms to ASME/ANSI B56.1 recommended practices. Failure to follow these practices may lead to serious bodily injury or property damage. End user, dealer and OEMs should review any deviation from the practices for safe operation.

**LONG ARM**  
(vertical & horizontal positions only)

**C** Release  
**D** Clamp

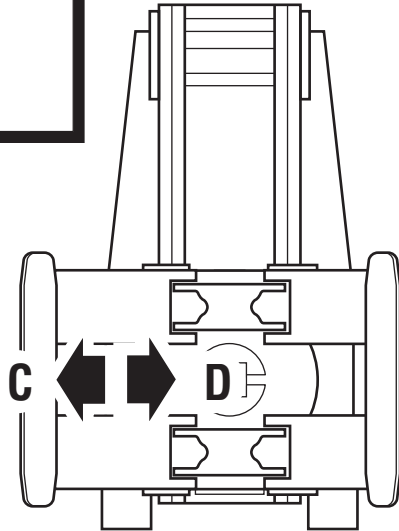

**ROTATE**  
(Driver's view)

**A** Counterclockwise (CCW)  
**B** Clockwise (CW)

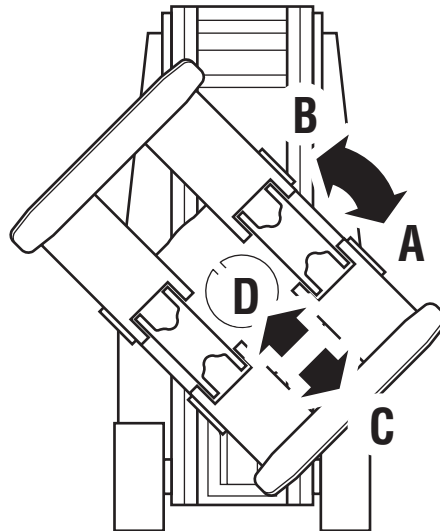

**SHORT ARM**  
(45-degree position only)

**C** Open  
**D** Close

The HFC system works fundamentally the same as a normal lift truck system when used with a paper roll clamp. Use the following techniques when clamping loads:

- 1 Clamp arms firmly on the roll. Hold for 1 second to build starting clamp pressure.
- 2 Lift the load. Clamp pressure will automatically increase according to load weight.
- 3 If feathering is used to reduce clamp force on light loads, use the same process with HFC. However, it is recommended to use the techniques above for all loads unless absolutely necessary.

**CAUTION:** Develop adequate clamp force to hold the load when feathering.

**4** Operation for a split arm clamp with HFC is the same as a solid arm clamp except for the following:

- HFC should be used with the Cascade full arm travel split arm circuit. Close the free arm fully when handling one roll with one split arm. Full clamp force develops after free arm bottoms.
- When clamping a full height roll with both split arms, operate the clamp as a solid arm clamp.

**NOTE:** HFC allows lower clamp starting pressures so that light loads can be handled without damage along with heavier loads. Slightly slower arm speed is normal. If roll diameters vary widely with very low starting pressures, the slower arm speed can be corrected with an optional arm overdrive system. Consult Cascade.

# TROUBLESHOOTING

**CAUTION:** Prior to troubleshooting, verify that clamp is working properly and check for defective check valves and cylinder seals.

**NOTE:** When adjusting cartridges, turn in 1/2 turn increments.

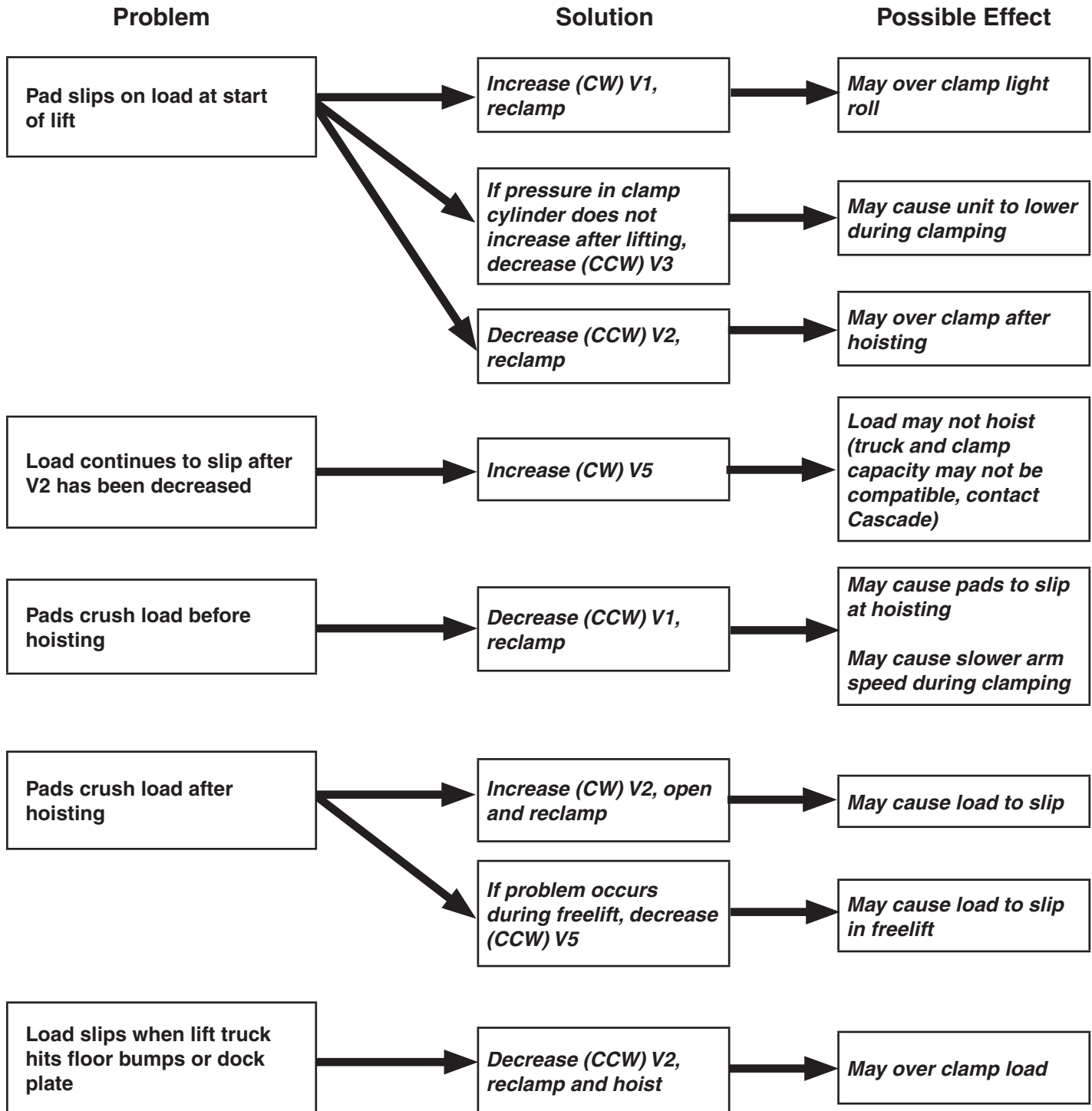

Problem	Solution	Possible Effect of Solution
Hoist cylinder will not lift with a high capacity load	Decrease (CCW) V5	May cause mainlift and freelift to be unbalanced
Hoist lowers while closing arms	Increase (CW) V3	May not add pressure during hoisting
Hoist speed is decreased	Decrease (CCW) V5	May have more clamp pressure in mainlift than freelift. Available clamping pressure in freelift will be reduced.
Clamped pressure is substantially higher in freelift over mainlift	Install switch if not installed	Improved accuracy
	Decrease (CCW) V5	Load may slip in freelift
Clamped pressure is substantially lower in freelift over mainlift	Increase (CW) V5	May over clamp in freelift
Over clamps when mast runs out of travel	Increase (CW) V4	May cut off needed clamp pressure on heavy loads
Arm speed is too slow during clamping	Increase (CW) V1	May over clamp light loads
	Light loads that require low starting pressure, install optional arm overdrive system	Driver may overclamp load if button is not released in time or relief not properly set.

# PARTS

## HYDRAULIC FORCE CONTROL KIT

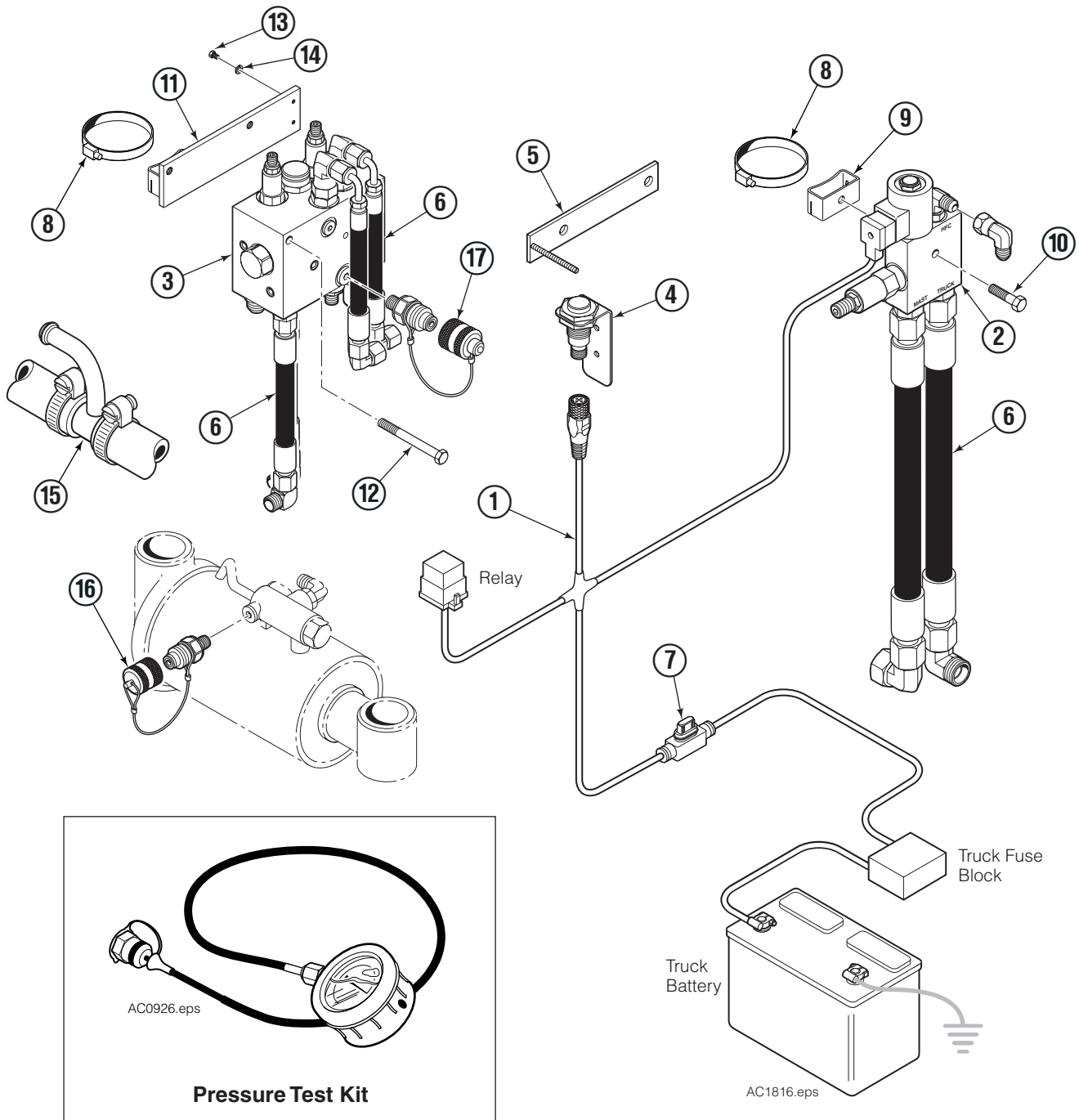

REF	QTY	PART NO.	DESCRIPTION	REF	QTY	PART NO.	DESCRIPTION
		6095869	HFC Kit	10	1	6405015	Capscrew, M8 X 35 ▲
1	1	6095957	Wire Harness ■	11	1	6098793	Bracket ▲
2	1	6095796	Equalizer Valve	12	2	6405022	Capscrew, M8 X 80 ▲
3	1	6088041	HFC Valve	13	2	765480	Capscrew, M4 X 10 ▲
4	1	6095969	Switch Assembly ■	14	2	685899	Lockwasher, M4 ▲
5	1	6095839	Switch Mounting Bracket ■	15	1	6098206	Return-to-Tank Kit
6	1	6097591	Fitting/Hose Group ●	16	2	6004478	Test Point Fitting, M16 X 7/16 SAE
7	1	6017897	Fuse – 5 amp	17	1	6006014	Test Point Fitting, M16 X 9/16 SAE
8	2	644585	Hose Clamp ▲		1	6034612	Pressure Test Kit
9	1	6098797	Adaptor ▲				

■ Included in Switch Group 6097590

▲ Included in Mounting Group 6098792

● For parts breakdown, refer to Fitting/Hose Group page

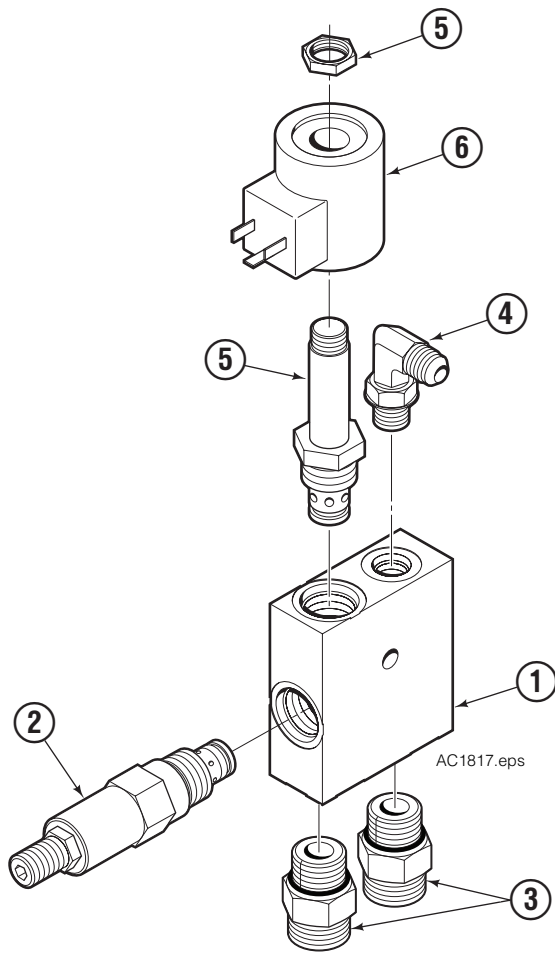

REF	QTY	PART NO.	DESCRIPTION
		6095796	Equalizer Valve
1	1	6095795	Valve Body
2	1	6088046	Relief Valve Cartridge
3	2	6234021	Fitting, Metric L
4	1	601676	Fitting, 6-6
5	1	6094473	Solenoid Valve
6	1	6014287	Coil - 12V

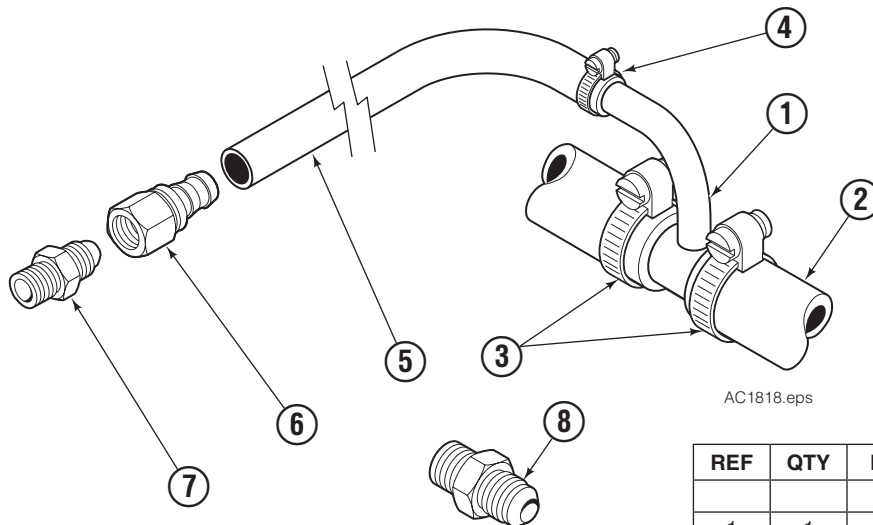

REF	QTY	PART NO.	DESCRIPTION
		6098206	Return-to-Tank Kit
1	1	6098117	Adaptor Tee
2	1	6098209	Hose
3	2	6098196	Hose Clamp
4	1	211742	Hose Clamp
5	1	211740	Hose, 72 in.
6	1	211741	Fitting, 8
7	1	601377	Fitting, 8-8
8	1	662187	Fitting, 8-6

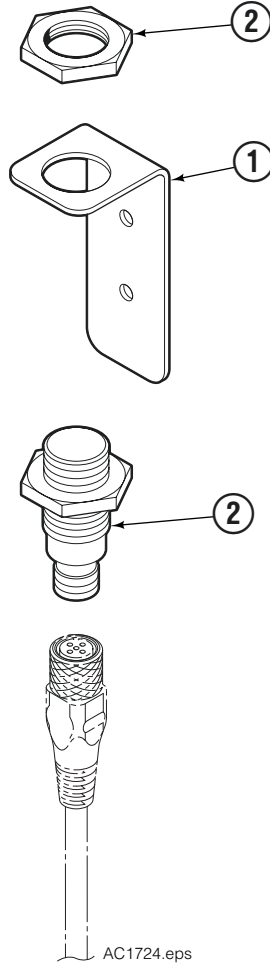

REF	QTY	PART NO.	DESCRIPTION
		6095969	Switch Assembly
1	1	6091430	Bracket
2	1	6092966	Switch

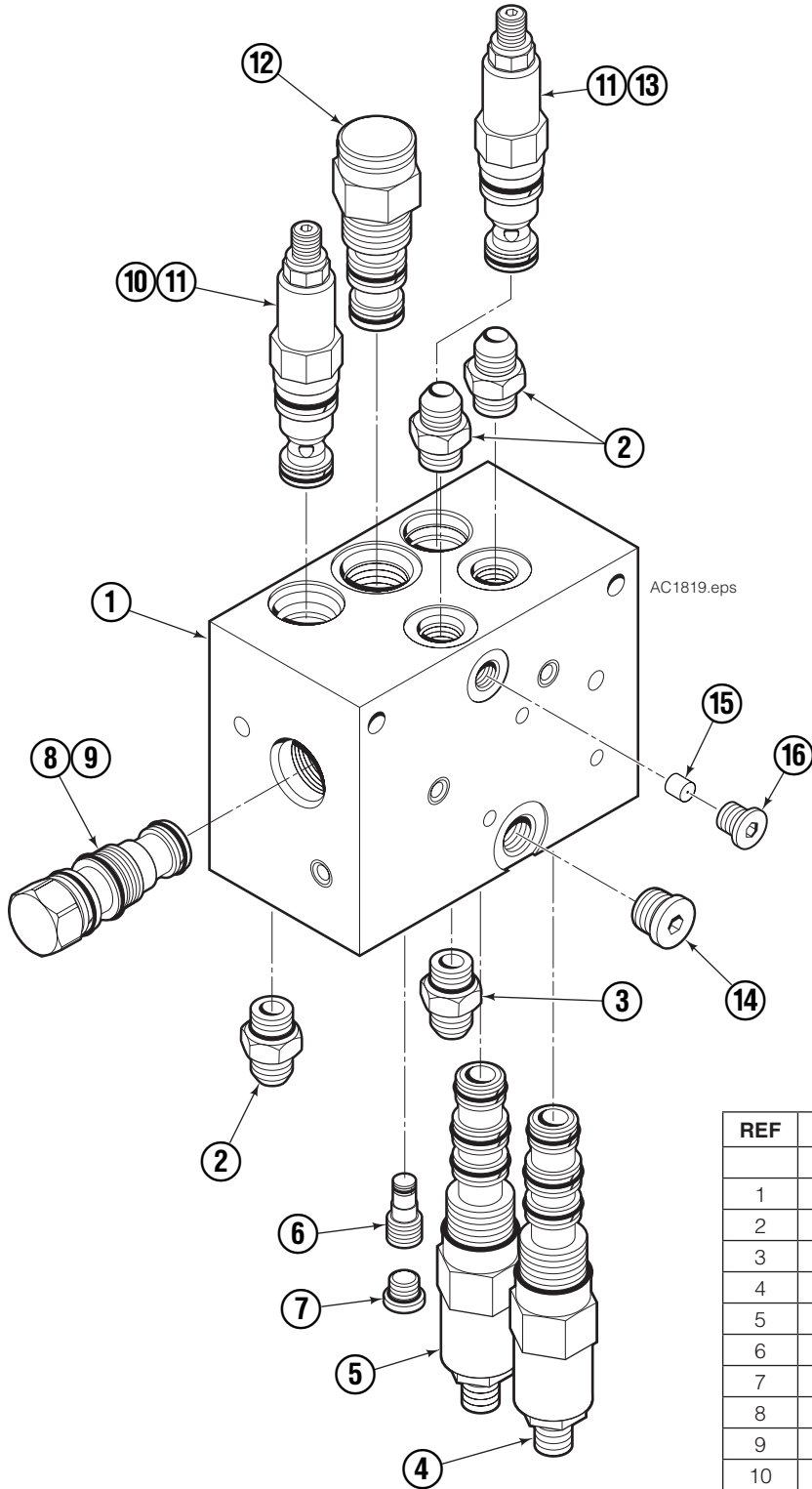

REF	QTY	PART NO.	DESCRIPTION
		6088041	HFC Valve ■
1	1	6088042	Valve Body
2	3	601377	Fittings
3	1	604511	Fitting
4	1	6091000	Pressure Sequence Valve Cartridge
5	1	6090999	Pressure Sequence Valve Cartridge
6	1	220865	Shuttle Valve
7	1	609234	Plug
8	1	210379	PO Check Valve Cartridge
9	1	6024964	Seal Kit
10	1	661676	Relief Valve Cartridge
11	2	661312	Seal Kit
12	1	6086327	Directional Valve Cartridge
13	1	6098001	Relief Valve Cartridge
14	1	604510	Plug
15	1	6054498	Orifice .020
16	1	663694	Plug

■ Refer to Glossary for flow requirements

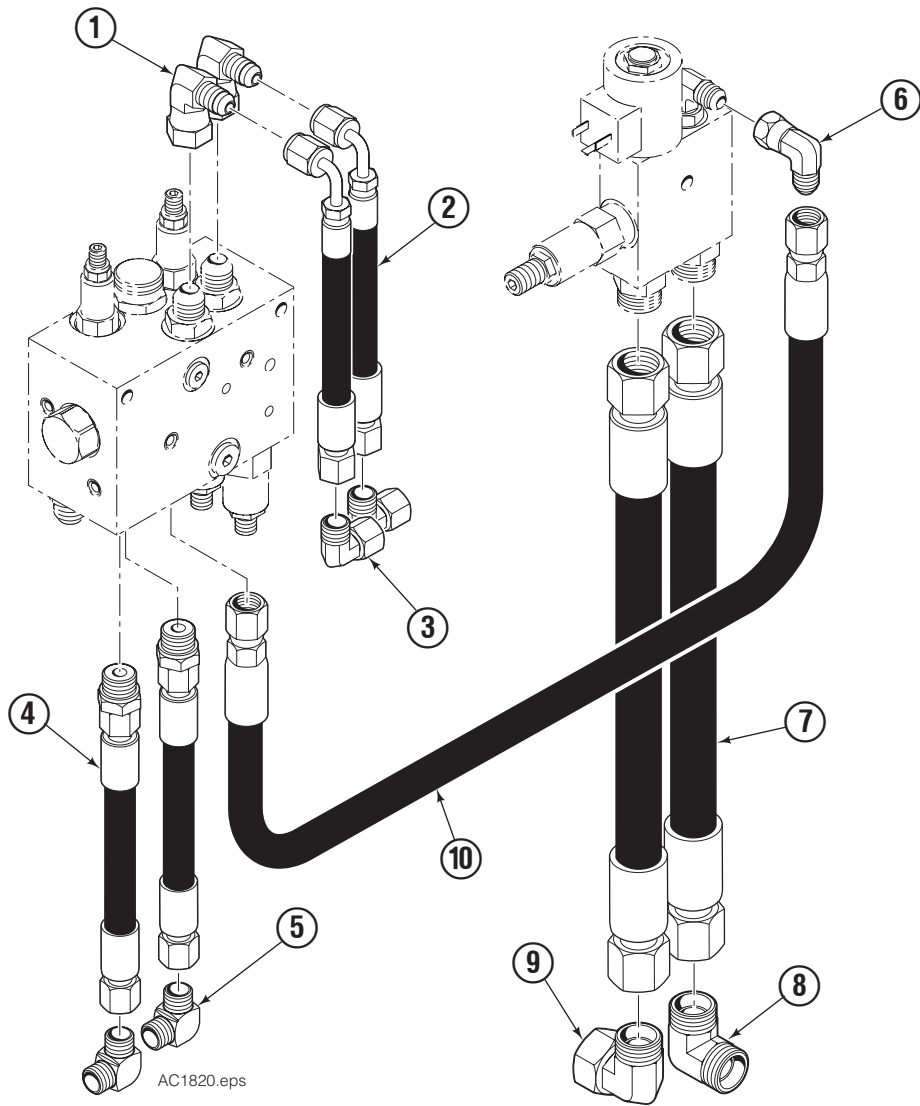

REF	QTY	PART NO.	DESCRIPTION
		6097591	Fitting/Hose Group
1	2	6099256	Fitting, 8-8
2	2	6098061	Hose
3	2	6095885	Fitting, M10L E0
4	2	6098060	Hose
5	2	6095887	Fitting, M10L E0
6	1	2680	Fitting, 6-6
7	2	6097873	Hose
8	2	6095870	Fitting, M18L
9	1	6234020	Fitting, M18L
10	1	666817	Hose, 40 in.

**Clamp Pressure** – Pressure set to clamp a load.

**Final Pressure (V2)** – The final HFC adjusted clamp pressure applied when the load is hoisted.

**Freelift Pressure (V5)** – Pressure in the hoist line when the mast is in freelift state.

**Mainlift Pressure (V5)** – Pressure in the hoist line when the mast has extended above freelift.

**Maximum Clamp Pressure (V4)** – The maximum pressure set to clamp a load.

**Overdrive System** – A system to aid with increasing arm speed and allows an attachment to have higher clamping pressure when breaking out rolls.

**Starting Pressure (V1)** – The minimum clamp pressure that will be applied, even on light loads.

**Static Hoist Pressure (V3)** – The hoist pressure to achieve prior to hoisting.

**Total Load Weight** – The sum of the paper roll weight and clamp weight.

**Do you have questions you need answered right now?**

Call your nearest Cascade Service Department.  
Visit us online at [www.cascorp.com](http://www.cascorp.com)

**AMERICAS**

**Cascade Corporation  
U.S. Headquarters**  
2201 NE 201st  
Fairview, OR 97024-9718  
Tel: 800-CASCADE (227-2233)  
Fax: 888-329-8207

**Cascade Canada Inc.**  
5570 Timberlea Blvd.  
Mississauga, Ontario  
Canada L4W-4M6  
Tel: 905-629-7777  
Fax: 905-629-7785

**Cascade do Brasil**  
Rua João Guerra, 134  
Macuco, Santos - SP  
Brasil 11015-130  
Tel: 55-13-2105-8800  
Fax: 55-13-2105-8899

**EUROPE-AFRICA**

**Cascade Italia S.R.L.  
European Headquarters**  
Via Dell'Artigianato 1  
37050 Vago di Lavagno (VR)  
Italy  
Tel: 39-045-8989111  
Fax: 39-045-8989160

**Cascade (Africa) Pty. Ltd.**  
PO Box 625, Isando 1600  
60A Steel Road  
Sparton, Kempton Park  
South Africa  
Tel: 27-11-975-9240  
Fax: 27-11-394-1147

**ASIA-PACIFIC**

**Cascade Japan Ltd.**  
2-23, 2-Chome,  
Kukuchi Nishimachi  
Amagasaki, Hyogo  
Japan, 661-0978  
Tel: 81-6-6420-9771  
Fax: 81-6-6420-9777

**Cascade Korea**  
121B 9L Namdong Ind.  
Complex, 691-8 Gojan-Dong  
Namdong-Ku  
Inchon, Korea  
Tel: +82-32-821-2051  
Fax: +82-32-821-2055

**Cascade-Xiamen**  
No. 668 Yangguang Rd.  
Xinyang Industrial Zone  
Haicang, Xiamen City  
Fujian Province  
P.R. China 361026  
Tel: 86-592-651-2500  
Fax: 86-592-651-2571

**Cascade India Material  
Handling Private Limited**  
No 34, Global Trade Centre  
1/1 Rambaugh Colony  
Lal Bahadur Shastri Road,  
Navi Peth, Pune 411 030  
(Maharashtra) India  
Phone: +91 020 2432 5490  
Fax: +91 020 2433 0881

**Cascade Australia Pty. Ltd.**  
1445 Ipswich Road  
Rocklea, QLD 4107  
Australia  
Tel: 1-800-227-223  
Fax: +61 7 3373-7333

**Cascade New Zealand**  
15 Ra Ora Drive  
East Tamaki, Auckland  
New Zealand  
Tel: +64-9-273-9136  
Fax: +64-9-273-9137

**Sunstream Industries  
Pte. Ltd.**  
18 Tuas South Street 5  
Singapore 637796  
Tel: +65-6795-7555  
Fax: +65-6863-1368

