



# Installation Instructions

## Conversion to 8 in. (200 mm) Forks for K-Series Fork Positioners. Kit 6093992

This Instruction Sheet provides instructions to convert K-Series Fork Positioners from 5, 6 or 7 in. forks to 8 in. forks by installing inner fork spacer bars and cylinder rod spacer collars.

- 1 Position fork carriers to mid-stroke and remove bolt-on inner fork retainers. Remove forks if installed.
- 2 Remove cylinder rod anchor plugs and slide fork carriers inward to expose split-ring keepers (see detail). Remove keepers.
- 3 Slide outer fork carriers outward to clear cylinder rods approximately 3.5 in. (90 mm). Install spacer collars on cylinder rods. **NOTE:** Spacers are necessary to prevent over-stroking when closing with 8 in. (200 mm) forks.
- 4 Slide outer fork carriers inward and reinstall split-ring keepers and anchor plugs. Use grease to hold split-rings in place. Tighten anchor plugs to 100 ft.-lbs. (135 Nm).
- 5 Install 8 in. (200 mm) forks and slide into position on outer fork carriers.
- 6 Remove (if installed) spacer block that is bolted to the inner retainer.
- 7 Install the new fork spacer bar and existing inner fork retainer. Tighten new longer capscrews to 50 ft.-lbs. (65 Nm).

### REMOVING/INSTALLING FORKS

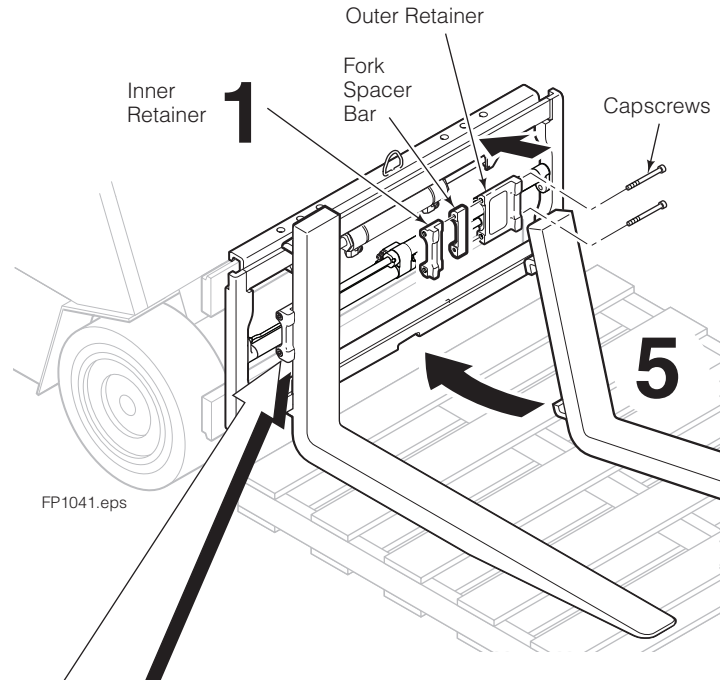

REF	QTY	PART NO.	DESCRIPTION
		6093992	Fork Conversion Kit
①	2	6069113	Spacer Bar
②	2	6093993	Spacer Collar
③	4	6405532	Capscrew, M12

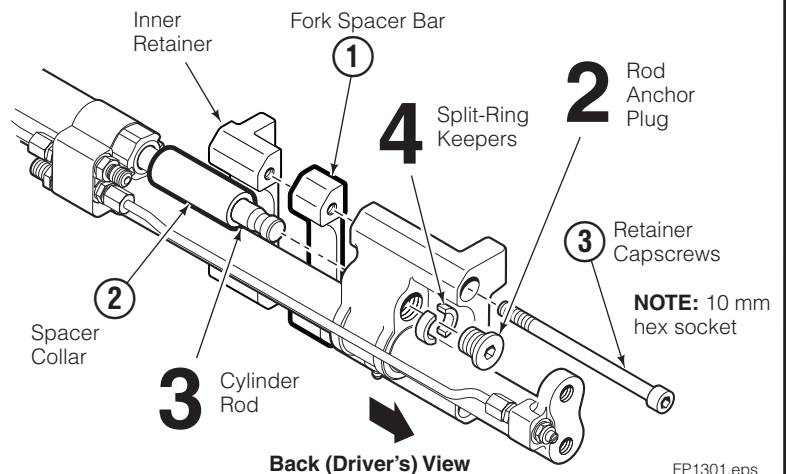

**cascade**<sup>®</sup>  
corporation

#### For Technical Support . . .

Call: 1-800-227-2233 Fax: 1-888-329-8207

Internet: [www.cascorp.com](http://www.cascorp.com)

Write: Cascade Corporation, PO Box 20187, Portland, OR 97294

© Cascade Corporation 2008

#### To Order Parts . . .

Call: 1-888-227-2233 Fax: 1-888-329-0234

Internet: [www.cascorp.com](http://www.cascorp.com)

Write: Cascade Corporation, 2501 Sheridan Ave., Springfield, OH 45505

10-2008

Part Number 6093994