



Installation Instructions

Fork Security Carriage Stops for 150D-SSS Sideshifters

This sheet describes the installation of Fork Security Carriage Stops. The stops consist of four Socket Head Capscrews, lockwashers and nuts.

- 1 Clean existing holes at end of upper and lower carriage bars.
- 2 Install four socket head capscrews, lockwashers and nuts.
- 3 Tighten the nuts to a torque of 80 ft.-lbs. (108 Nm).

Description	Cascade Part No.
Capscrews – .50 NC X 2.50 Grade 8	4510
Lockwashers – .50 in.	6290
Nuts – .50 NC Grade 8	5901

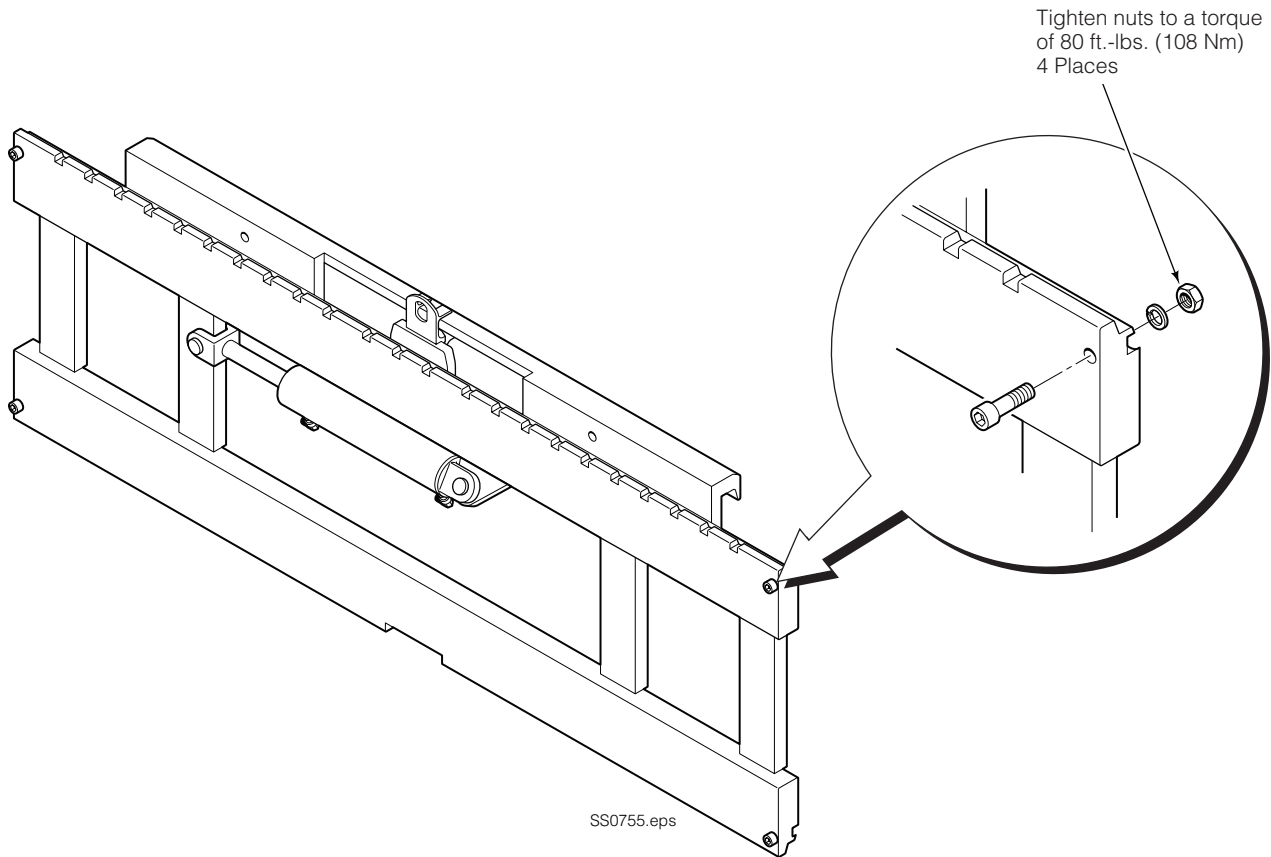

NOTE: This information should not be interpreted as the basis for warranty claims unless so designated.

cascade[®]
corporation

For Technical Support . . .

Call: 1-800-227-2233 Fax: 1-888-329-8207
Internet: www.cascorp.com
Write: Cascade Corporation, PO Box 20187, Portland, OR 97294

© Cascade Corporation 2007

To Order Parts . . .

Call: 1-888-227-2233 Fax: 1-888-329-0234
Internet: www.cascorp.com
Write: Cascade Corporation, 2501 Sheridan Ave., Springfield, OH 45505

6-2007

Part No. 6078363