



# Installation Instructions

## Electronic Rotational Control 77F Retrofit Kit 6019646

Electronic Rotational Control requires accurately located tapped holes for proper installation. For those Cascade Paper Roll Clamps that have not been pre-drilled for ERC the following steps are recommended for accurately locating the required holes. (This list does not determine for the Technician when he needs to dismount the attachment.)

- 1 Using one of the outer race capscrew holes, locate the Switch Bracket jig as indicated by the layout.
- 2 Mark Switch Bracket holes using transfer punch 6019664 (13/64").
- 3 Remove jig.
- 4 Reinstall and tighten the outer race capscrew to 80 ft.-lbs. (110 Nm).
- 5 Drill and tap Switch Bracket holes (M8 x 1,25) according to layout. Use tap drill and tap included in ECR Retrofit kit.
- 6 Mount Switch Bracket (222021) to Baseplate according to ERC retrofit install instructions (228724).
- 7 Mount Faceplate jig (228702) to Switch bracket using M5 cap screws included in ERC retrofit kit.
- 8 Tilt the truck mast so that the Short Arm Contact Pad is vertical in the tilting plane.
- 9 Rotate the Paper Roll Clamp until the Short Arm Contact Pad is vertical (use a leveling device to ensure accuracy) in the attachment rotating plane.
- 10 Using the two holes closest to the centerline of the faceplate jig, use transfer punch 6019664 (13/64") to locate two new holes in the faceplate.
- 11 Rotate the Paper Roll Clamp until the Short arm Contact Pad is down and horizontal in the 'bilge' position (use a leveling device to ensure accuracy).
- 12 Mark two new hole locations on the faceplate the same as step 10.
- 13 Rotate the Paper Roll Clamp until the Short Arm Contact Pad is on the other side from step 9. Ensure the Contact Pad is vertical (use a leveling device to ensure accuracy) in the attachment rotating plane.
- 14 Mark two new hole locations on the faceplate the same as step 10.
- 15 Drill and tap faceplate holes (M6 x 1,0) using tap drill and tap provided in the ERC Retrofit kit.
- 16 Locate the holes for the ERC Relay enclosure per Layout. Drill and tap (M6 x 1,0).
- 17 Proceed as directed by installation instructions 228724.

Part No. 6019665-R1

# cascade®

#### For Technical Support . . .

Call: 1-800-227-2233

**OR**

Write: Cascade Corporation, P.O. Box 20187, Portland, OR 97294

#### To Order Parts . . .

Call: 1-888-227-2233

**OR**

Write: Cascade Corporation, 2501 Sheridan Ave., Springfield, OH 45505

Faceplate holes located  
and drilled in step 12.  
Tap holes M6 x 1.

Baseplate holes located  
and drilled in step 17.  
Tap holes M6 x 1.

Faceplate holes located  
and drilled in step 10.  
Tap holes M6 x 1.

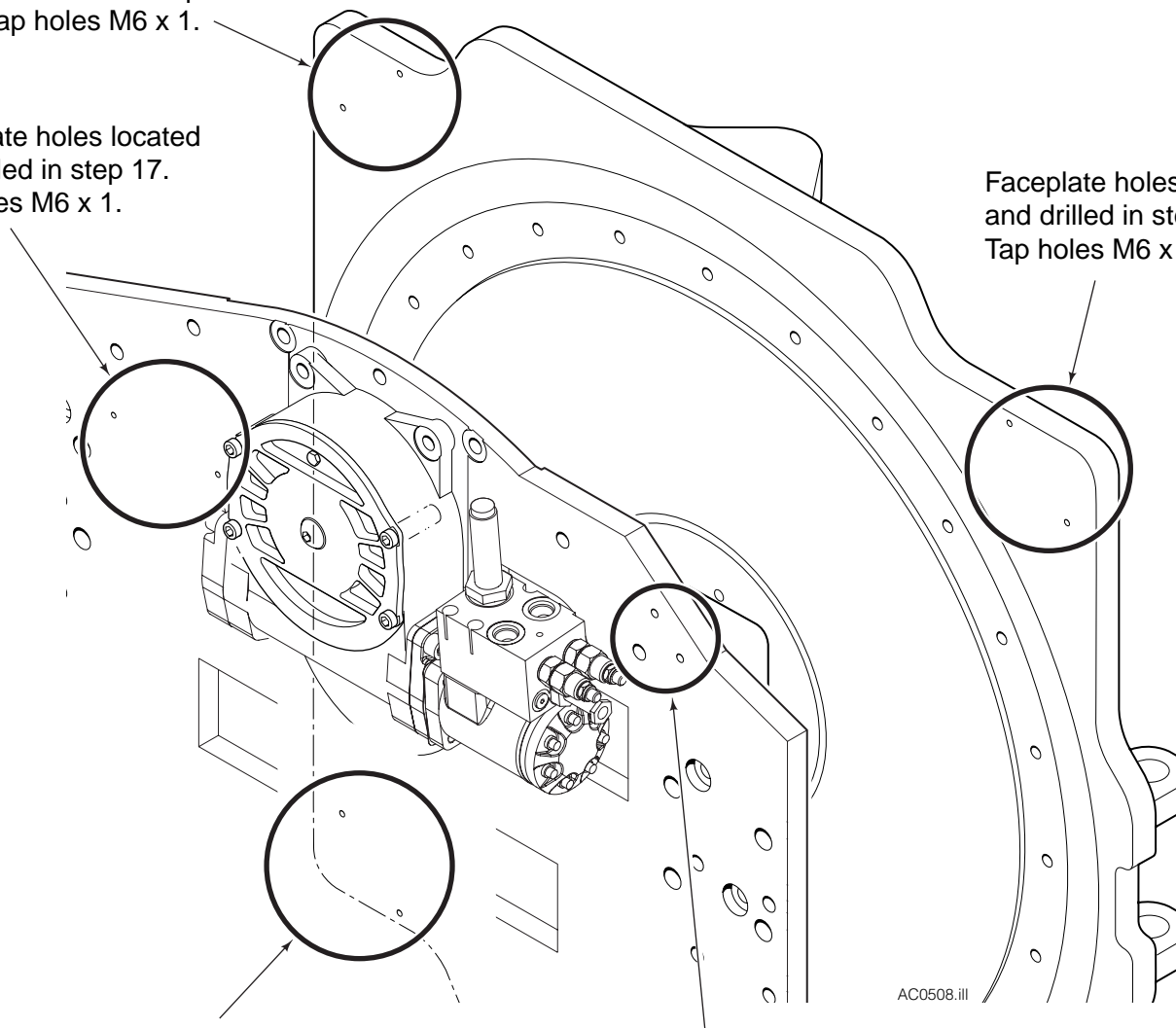

Faceplate holes located  
and drilled in step 15.  
Tap holes M6 x 1.

Baseplate holes located  
and drilled in steps 1 through 5.  
Tap holes M8 x 1,25.

AC0508.iii

Align template edge parallel to edge of baseplate. Mark hole locations as described in step 2.

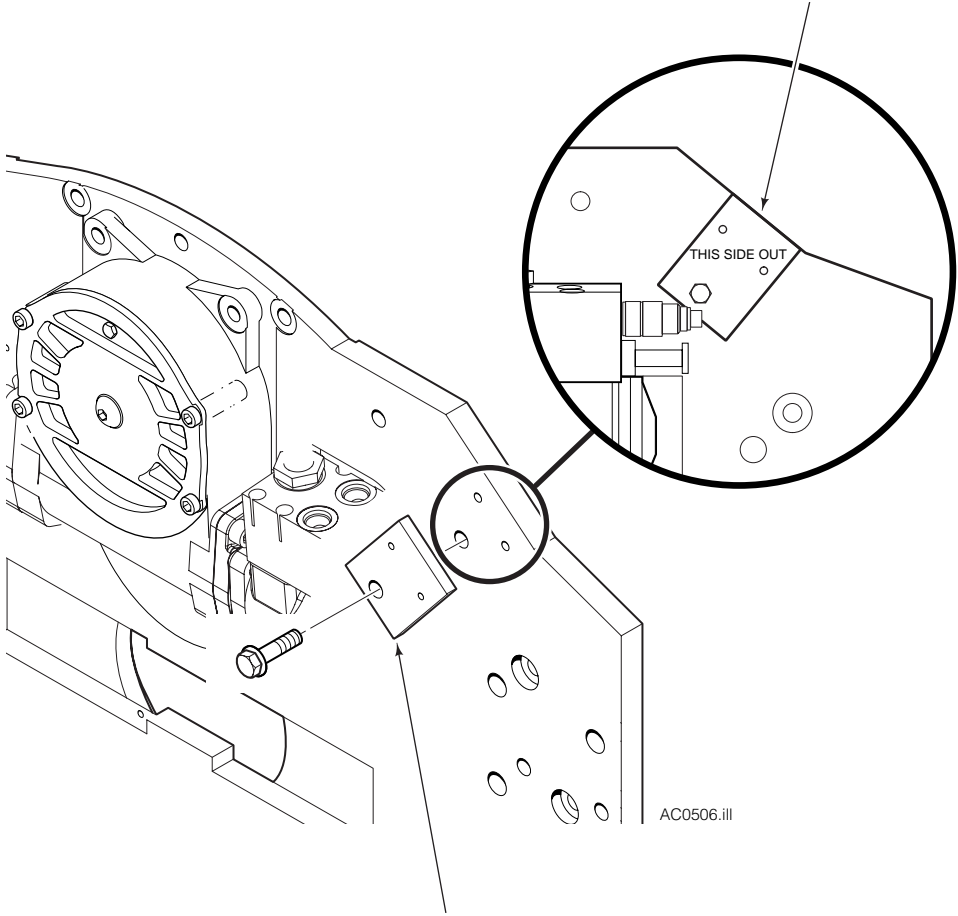

Install template using existing capscrew as described in steps 1 through 4.

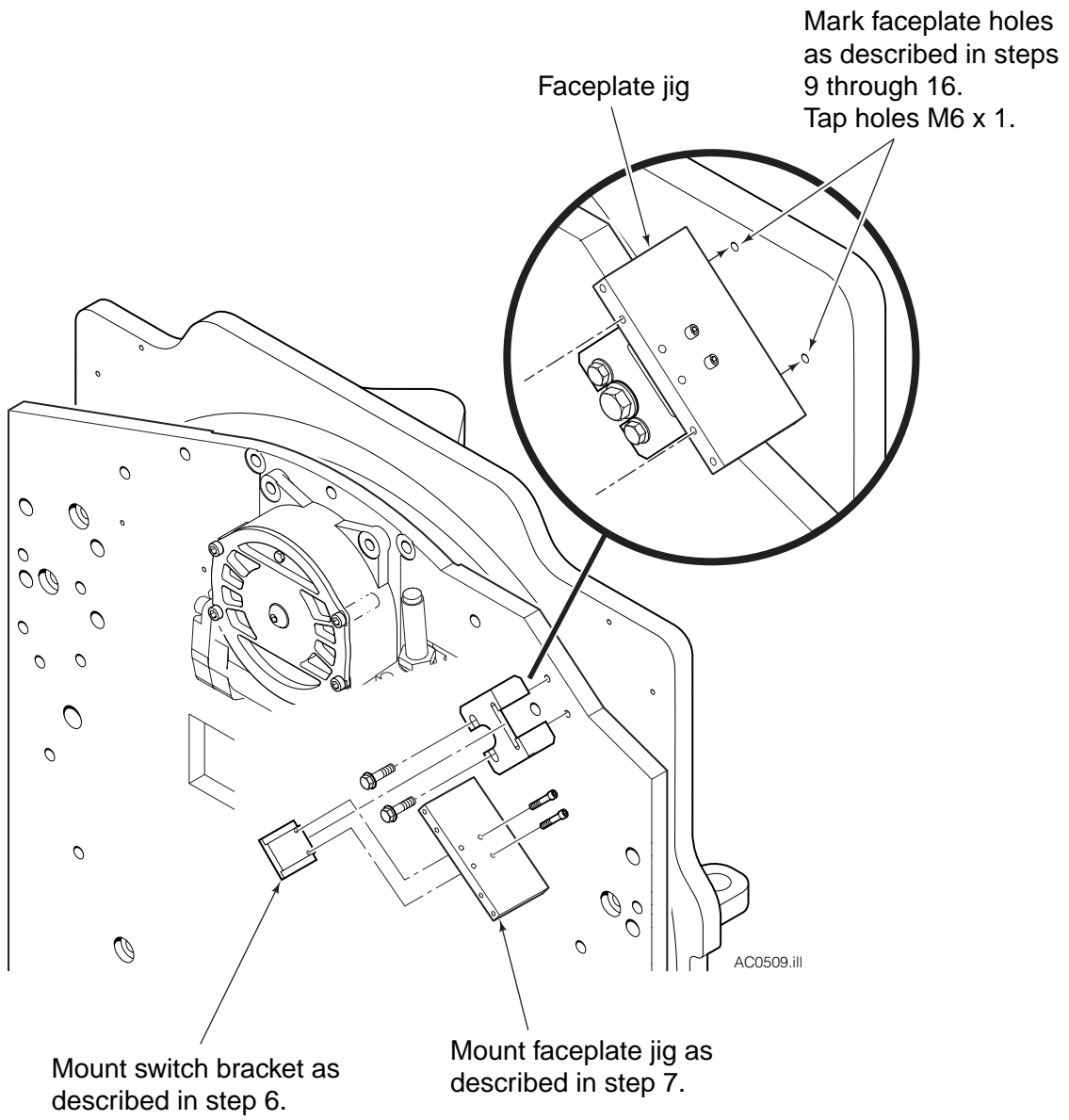

Locate mounting holes  
for relay box as described  
in step 17. Drill and  
tap M6 x1 holes.

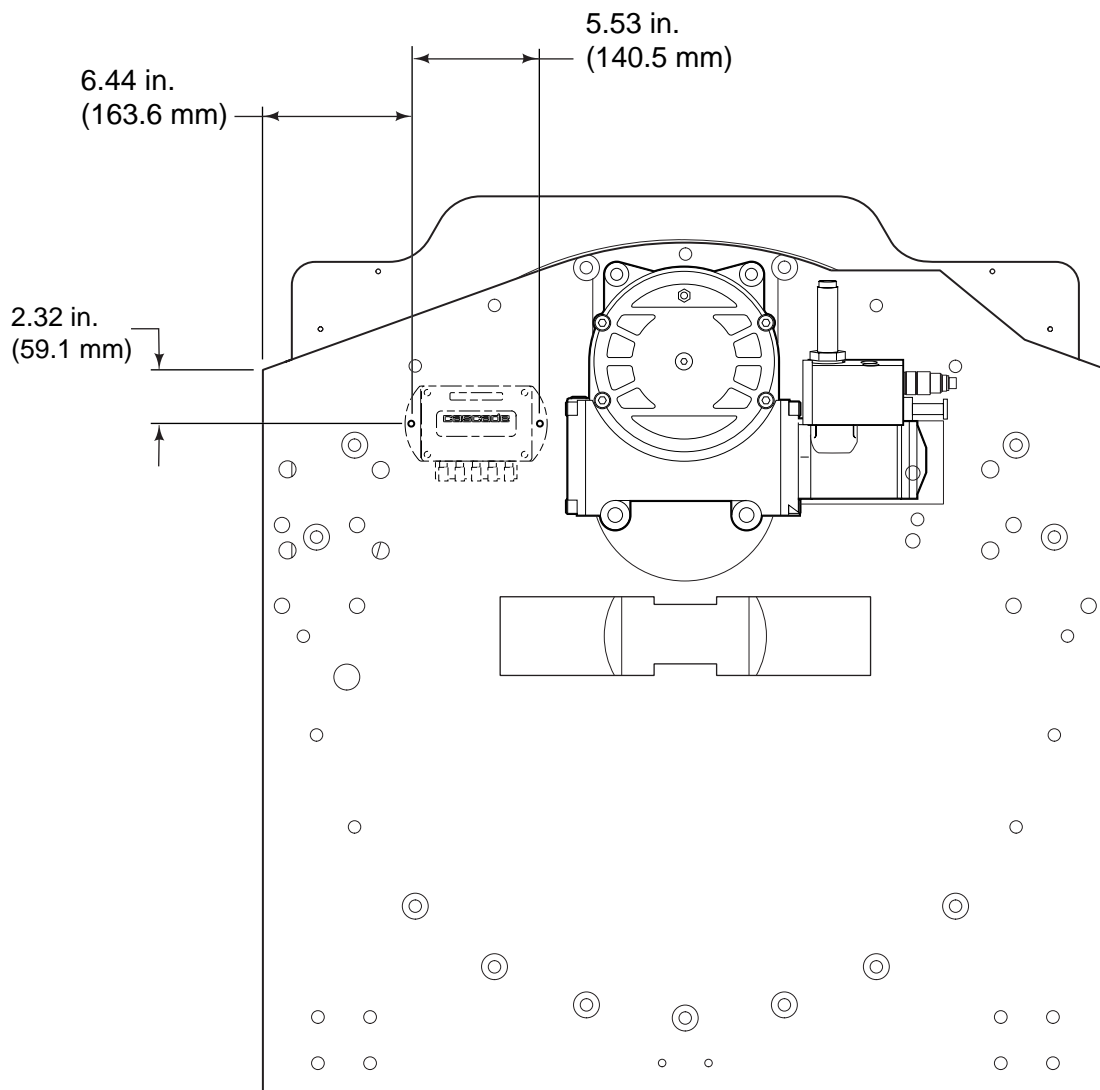

**Do you have questions you need answered right now?** Call your nearest Cascade Service Department.

**Cascade Corporation  
U.S. Headquarters**  
2201 NE 201st  
Fairview, OR 97024-9718  
Tel: 800-CASCADE (227-2233)  
FAX: 888-329-8207

**Cascade Canada Inc.**  
5570 Timberlea Blvd.  
Mississauga, Ontario  
Canada L4W-4M6  
Tel: 905-629-7777  
FAX: 905-629-7785

**Cascade GmbH**  
D-41199 Monchengladbach  
Klosterhofweg 52  
Germany  
Tel: 21-66-602091  
FAX: 21-66-680947

**Cascade Finland**  
01370 Vantas  
Finland  
Tel: 358-0-836-1925  
FAX: 358-0-836-1935

**Cascade N.V.  
European Headquarters**  
P.O. Box 3009  
1300 El Almere  
Damsluisweg 56  
1332 ED Almere  
The Netherlands  
Tel: 31-36-5492911  
FAX: 31-36-5492964

**Cascade N.V.  
Benelux Sales and Service**  
P.O. Box 3009  
1300 El Almere  
Damsluisweg 56  
1332 ED Almere  
The Netherlands  
Tel: 31-36-5492950  
FAX: 31-36-5492974

**Cascade (UK) Ltd.**  
15, Orgreave Crescent  
Dore House Industrial Estate  
Handsworth  
Sheffield S13 9NQ  
England  
Tel: 742-697524  
FAX: 742-695121

**Cascade Scandinavia  
Hydraulik A.B.**  
Muskötgatan 19, E8-9  
S25466 Helsingborg  
Sweden  
Tel: 42-151135  
FAX: 42-152997

**Cascade Norway**  
Østerliveien 37A  
1153 Oslo  
Norway  
Tel: 47-22-743160  
FAX: 47-22-743157

**Cascade France S.A.R.L.**  
11, Rue Jean Charcot  
Zone Industrielle Sud or  
B.P. 22  
91421 Morangis Cedex  
France  
Tel: 1- 64547501  
FAX: 1-9790584

**Cascade Hispania S.A.**  
Avenida De La Fabregada, 7  
Hospitalet De Llobregat  
Barcelona  
Spain  
Tel: 3-335-5158  
FAX: 3-335-4756

**Cascade Japan Ltd.**  
5-5-41,  
Torikai Kami  
Settsu, Osaka  
Japan, 566  
Tel: 81-726-53-3490  
FAX: 81-726-53-3497

**Cascade Korea**  
Room 508, Pum Yang Bldg.  
750-14, Bang Bac-Dong  
Se-Cho Ku, Seoul  
Korea  
Tel: 2599-7131 ext. 512  
FAX: 2533-8089

**HYCO-Cascade Pty. Ltd.**  
87 Antimony Street  
Carole Park,  
Brisbane 4300  
Australia  
Tel: 7-271-1966  
FAX: 7-271-3830

**HYCO-Cascade (NZ) Ltd.**  
15 Ra Ora Drive, East Tamaki  
P.O. Box 38-440  
Howick, Auckland  
New Zealand  
Tel: 9-273-9136  
FAX: 9-273-9137

**Cascade (Africa) Pty. Ltd.**  
P.O. Box 625, Isando 1600  
60A Steel Road  
Sparton, Kempton Park  
South Africa  
Tel: 975-9240  
FAX: 394-1147

**Cascade-Xiamen**  
Wanshan No. 1 Workshop  
Huli Road  
Xiamen 361006  
Fujian, PRC  
Tel: 592-562-4600  
FAX: 592-562-4671

**Cascade (Singapore)  
Trading Co.**  
Four Seasons Park  
Autumn Block - Apt. 1802  
12 Cascaden Walk  
Singapore  
Tel: 65-834-1935  
FAX: 65-834-1936

