



# Technical Bulletin

## D-Series Carton Clamp Stabilizer Retaining Pin Service Kit

Procedures for the installation of D-Series Carton Clamp - Stabilizer Retaining Pin Service Kit 674191. The kit includes 2 snap rings (7189 and 7193) and 1 retaining pin (669687). Four kits are required per clamp.

Models: 20D, 35D and 60D Carton Clamps

- 1** Note the location of the indicator mark on the top surface of the eccentric pin. Do not rotate the eccentric pin during installation of the new retaining pin. Rotating the pin 180° will change the arm camber.
- 2** Remove the old snap ring and retaining pin, discard these parts.
- 3** Wind one of the new snap rings through the hole in the new retaining pin. Use the small diameter snap ring for 20D/35D clamps or the large diameter snap ring for 60D clamps.
- 4** Install the retaining pin through the eccentric pin and into the stabilizer. Position the snap ring over the top of the eccentric pin.
- 5** Wind the snap ring past the retaining pin to position it between the stabilizer and retaining pin.

Note: Wind the snap ring (CW) clockwise for the left side of the attachment or (CCW) counter clockwise for the right side.

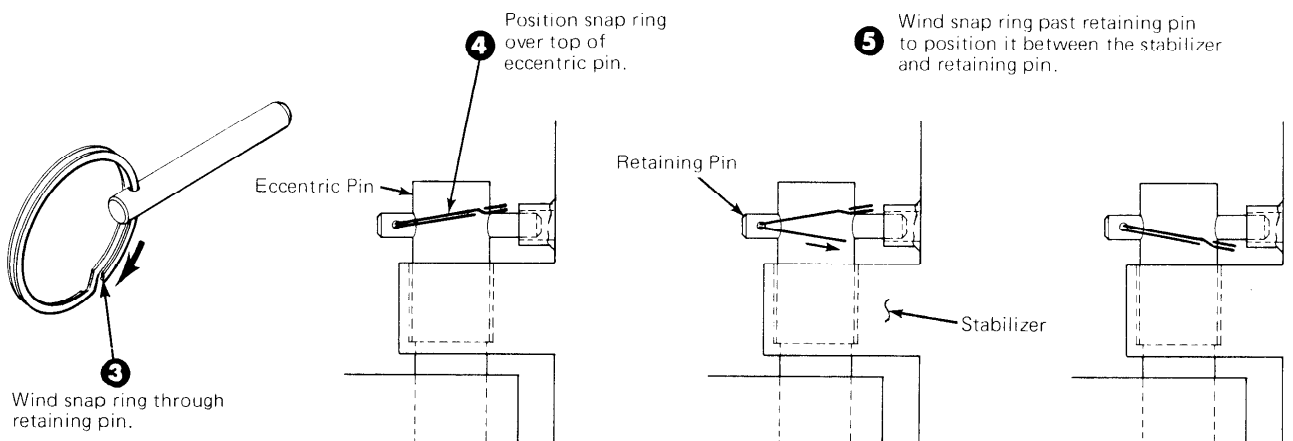
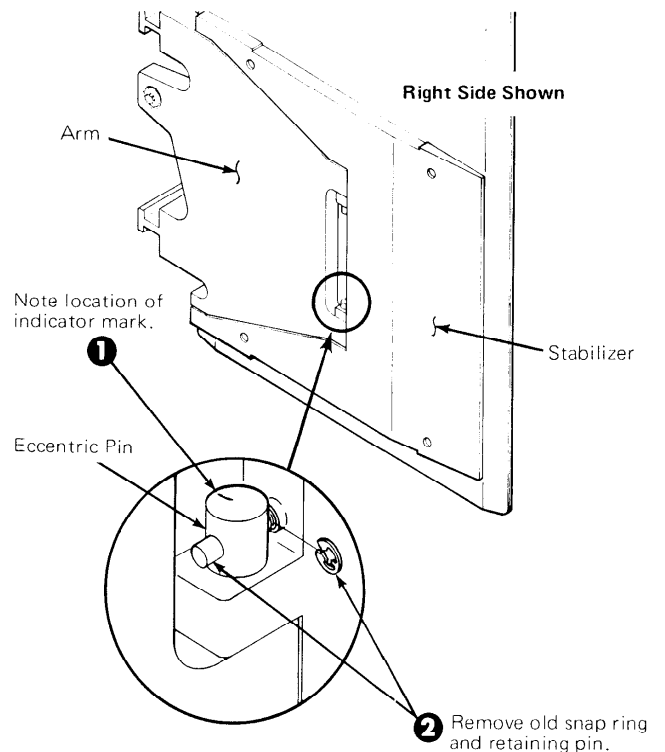

# cascade<sup>®</sup> corporation

P.O. Box 20187 • Portland, Oregon 97220 • (503) 666 1511  
P.O. Box 360 • Springfield, Ohio 45505 • (513) 325-9274

Do you have questions  
you need answered  
right now?

Don Dierckx  
800 727-2233  
ext 300