



Installation Service and Parts Manual

H2R and H2L Cable Reel

Serial Numbers 662407 through 669714

Manual Number 662406-R1

cascade[®]

Cascade is a Registered Trademark of Cascade Corporation

CONTENTS

INTRODUCTION.....	1
PRIOR TO INSTALLATION.....	1
INSTALLATION.....	2
SERVICE	
SEAL AND SPRING ASSEMBLY REPLACEMENT.....	4
INNER CABLE REPLACEMENT.....	8
OUTER CABLE REPLACEMENT.....	10
TROUBLESHOOTING GUIDE.....	11
ELECTRICAL TROUBLESHOOTING GUIDE.....	12
CABLE LENGTHS.....	13-14
PARTS LISTS.....	14-16

INTRODUCTION

This booklet contains the complete PARTS, INSTALLATION, and SERVICE information for the H2R and H2L Cable Reels. The manual also includes TROUBLESHOOTING GUIDES located on page 11 and 12. If you have additional questions, call the nearest Cascade Service Department listed on back cover.

To order replacement parts contact the Cascade Central Parts Depot at:

Cascade Corporation
P.O. Box 360
Springfield, Ohio 45505
(513) 322-1199
TELEX: 205413

PRIOR TO INSTALLATION

To make the truck and attachment cables compatible with the reel cable connectors, attach the pin and socket connectors (included with the reel) to the truck and attachment cable ends according to the following procedures.

1. Crimp the pin connectors to the truck cable end with VACO Part No. 1900 or Waldom Part No. HT 1919 one of which is included in Tool Kit Part No. 676314. (six pin connectors are supplied with the reel; however, use only one pin connector per function plus one additional pin connector as a ground).
2. Install the pin connector housing.

CAUTION: To maintain a uniform electrical circuit and to prevent electrical shocks, establish a connection pattern to be used at all connector locations.

3. Crimp the socket connectors to the attachment cable end with VACO Part No. 1900 or Waldom Part No. HT 1919 one of which is included in Tool Kit Part No. 676314 (six socket connectors are supplied with the reel; however, use only one socket connector per function plus one additional socket connector as a ground).
4. Install the socket connector housing using the established connection pattern.

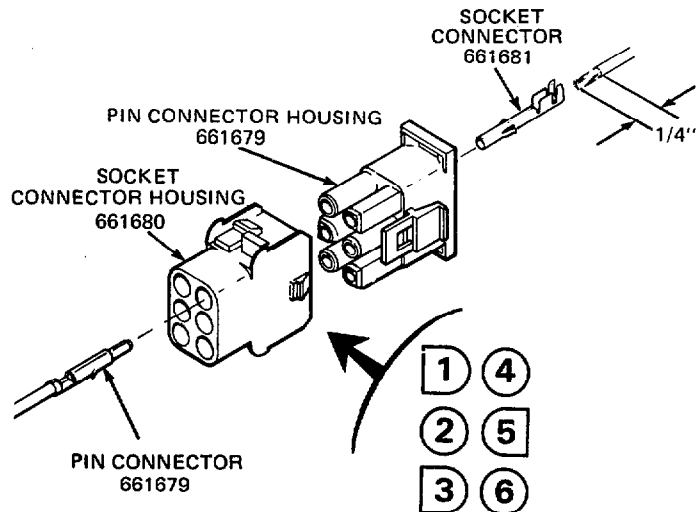

NOTE: The following information is supplied for your convenience in establishing a connection pattern. The wire harness installed in the cable-hose reel is connected to the pins or sockets in the following pattern:

- | | |
|----------------|--------------------|
| Pin/Socket No. | 1 - Purple |
| | 2 - Green |
| | 3 - Black or Blue |
| | 4 - Yellow or Pink |
| | 5 - White |
| | 6 - Red |

INSTALLATION

IMPORTANT: Do not allow the reel to rotate on its shaft at this time. Doing so will prewind the spring. The wire attaching the Caution Tag to the reel must stay in place until the reel is to be prewound and cable connected to the junction block.

1. Determine a location for the mounting pad keeping in mind the following points:
 - a. **Locate the mounting pad** on the mast channel or truck cowling. See Figure 1. **The cable reel flanges must not interfere with:**
 - The truck overhead guard when the mast is tilted all the way back (if the reel is mounted on the mast).
 - The truck carriage as it moves past the reel (if the reel is mounted on the mast).
 - The mast channel members when the mast is tilted all the way back (if the reel is mounted on the truck cowling).

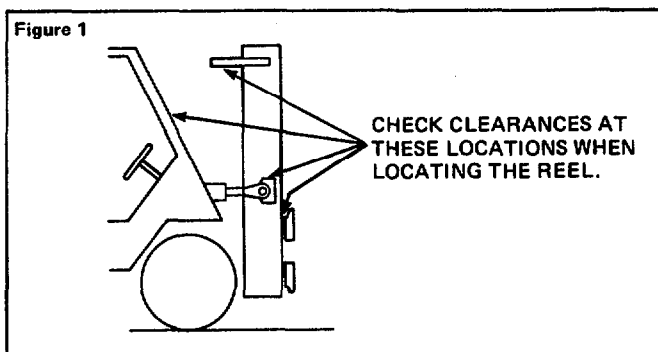

- b. The inner reel flange should be no more than 1/4" from the side of the mast, and should be placed behind the mast channel rather than along side it. See Figure 2.
- c. The reel should not extend beyond the widest part of the truck to prevent possible damage to the reel during truck operation.

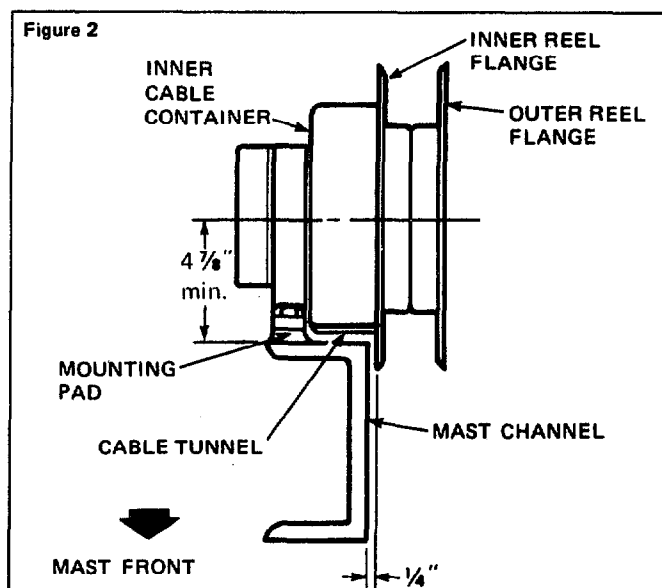

- d. If you are not using the Cascade Mounting Pad make sure that your pad has a thickness of at least 5/8 inch.
2. Weld the mounting pad in place using a 3/16" fillet weld (use E60XX rod with no preheat or postheat) along the vertical sides of the mounting pad only. See Figure 3. Cover the hoist chains to shield from weld splatter.
3. Attach the reel mounting brackets to the mounting pad using the mounting cap screws and lockwashers supplied with the cable reel. See Figure 3.

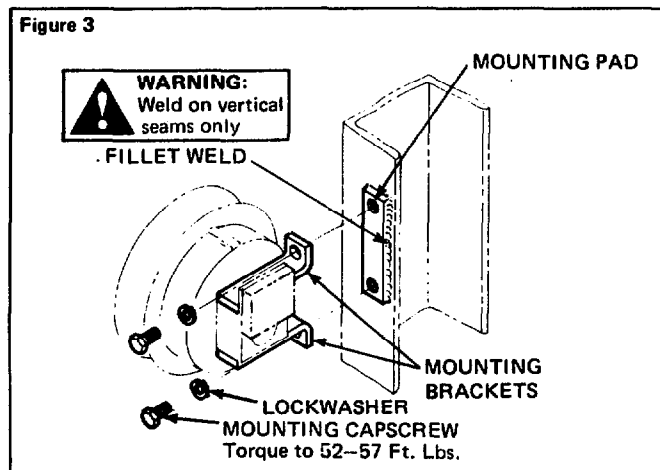

4. Remove the fixed cover from the mounting block on the backside of the reel. See Figure 4.
5. Join the cable connector of the inner cable to the cable connector of the truck cable using the established connection pattern for all cable ends. See page 1.
6. Remove the clamp from the mounting block and fit it around the truck cable. Reinstall the clamp on the reel mounting block. See Figure 4.

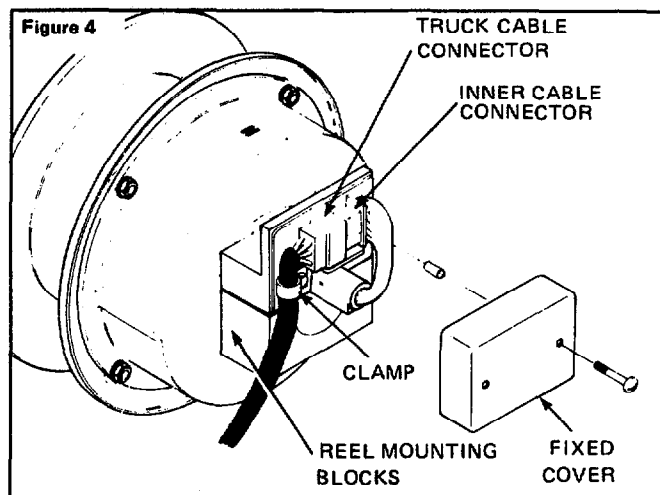

7. Install the fixed cover on the mounting block. Tighten the screws.

CAUTION: Overtightening the screws will damage the fixed cover.

8. Raise the carriage to a position approximately even with the top of the cable reel. The junction block should be positioned so that it is centered between the reel flanges. See Figure 5. Using the junction block as a guide, mark the location of the junction block mounting holes on the back side of the carriage. Make sure the junction block is positioned vertically.
9. Lower the truck carriage to the floor.
10. Drill and tap both holes at the location marked on the carriage. Figure 5 shows the diameter and drilling information for the two holes. The thread depth should be drilled a minimum of 1/2 inch.

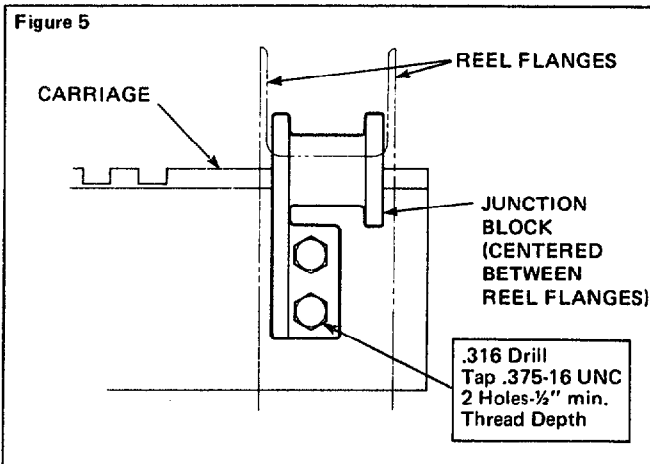

11. Install the junction block on the carriage using the cap-screws and lockwashers supplied with the junction block.
 12. Determine the cable length required as shown in the Cable Length Calculations, see page 13.
- NOTE:** This step may be by-passed if you have been supplied with a pre-assembled cable of the correct length.
13. To install the outer cable on the reel remove the three hub nuts securing the rotating cover to the outer flange. Remove the rotating cover. See Figure 6.
 14. Join the outer cable connector to the inner cable connector using the established connection pattern. See Figure 6.
 15. Fit the cable clamps to the outer cable and secure them on each side of the rotating cover. See Figure 6.
 16. Install the rotating cover and hub nuts. The inner cable must be laying flat in the flange depression and not pinched. Tighten the hub nuts.

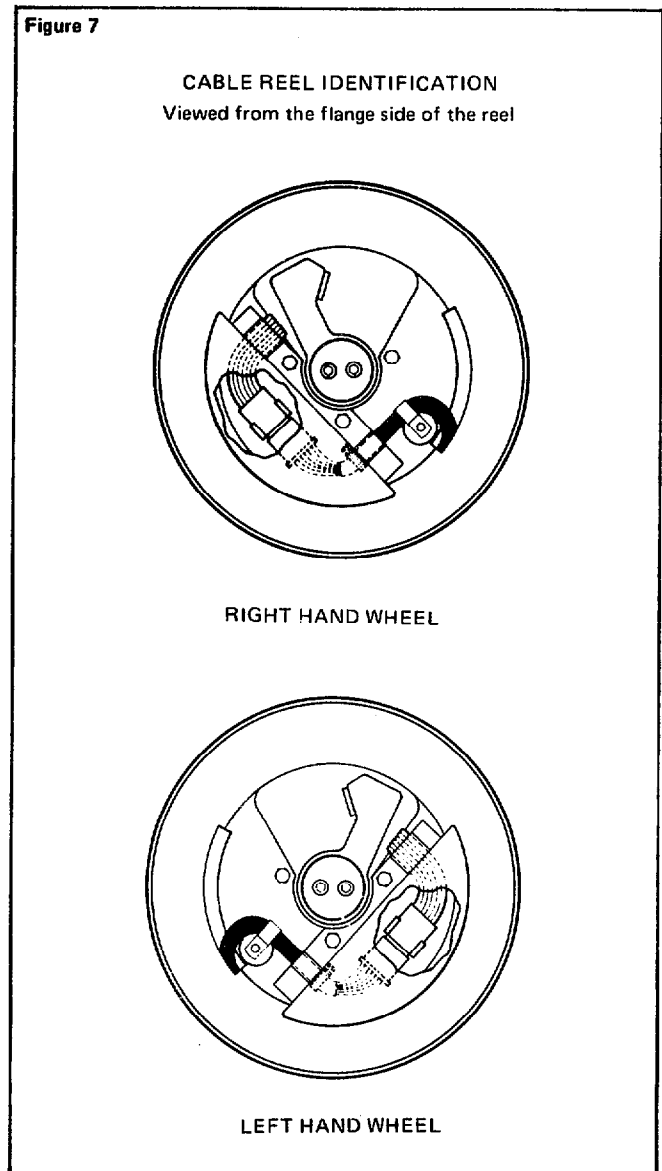
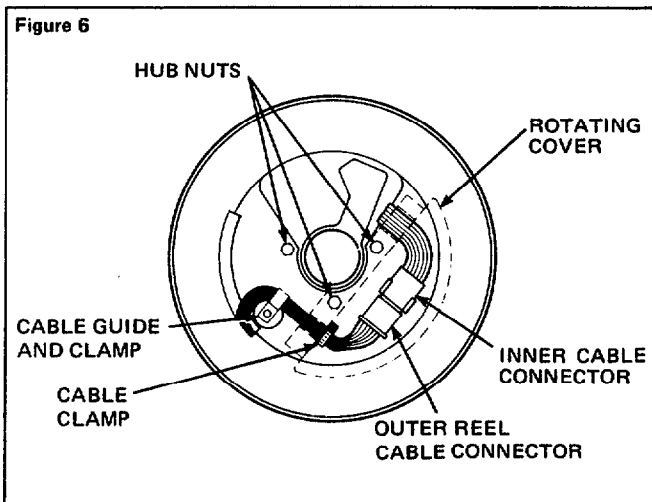

17. Wind the outer cable completely onto the reel in the direction indicated (viewed from the flange side): See Figure 7.

Right Hand Reel: Wind cable clockwise.
Left Hand Reel: Wind cable counterclockwise.

A Right or Left hand reel is determined as viewed from the flange side of the reel. See Figure 7.

18. Remove the caution tag and wire.
19. Prewind the reel spring by grasping the end of the outer cable and turning the reel a minimum of 3 turns in the direction indicated (viewed from the flange side):

Right Hand Reel: Wind reel clockwise.
Left Hand Reel: Wind reel counterclockwise.

CAUTION: Rotation in a wrong direction will damage the inner cable and reel spring.

If more tension is required the reel can be prewound additional turns. The maximum turn capacity is 16 turns.

Total turns = Prewind turns + Working turns.

CAUTION: Exceeding turn capacity of the reel will damage the inner cable and reel spring.

20. With the reel prewound, pull the cable end down to the junction block. Loop once and fasten securely with outer cable clamp. See Figure 8.

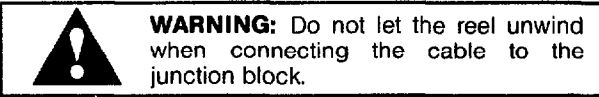

21. Connect the attachment cable connector to the cable connector at the junction block. See Figure 8.
22. Operate the carriage up and down a few times to make sure the cable tracks smoothly and no interference exists.

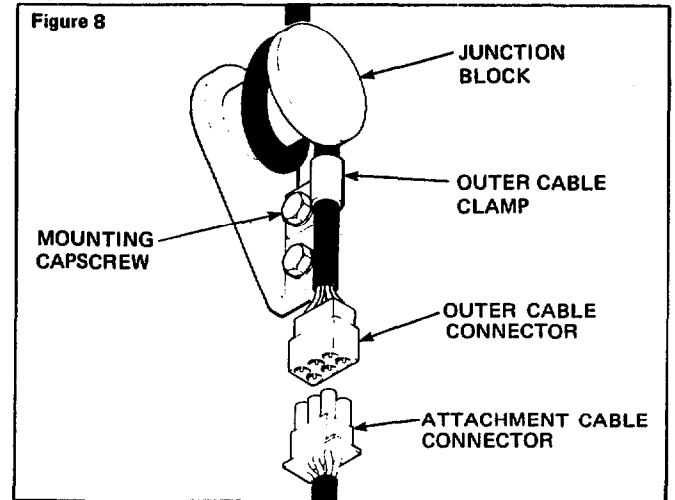

SEAL AND SPRING ASSEMBLY REPLACEMENT

DISCONNECTING THE REEL

1. Disconnect the connectors at the junction block.

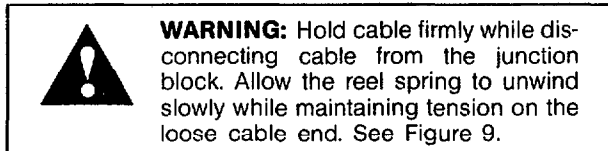

2. Remove the cable from the junction block.

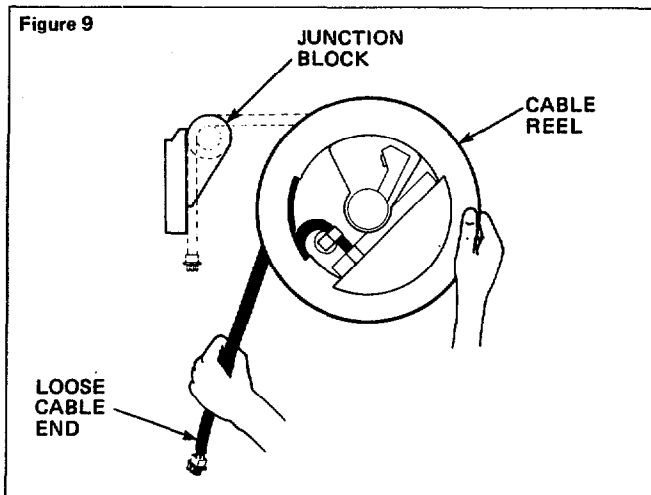

3. Remove fixed cover from the mounting block. Disconnect the inner reel cable connector from truck cable connector. See Figure 4.
4. Remove the capscrews and lockwashers fastening the reel to the mounting pad. Remove the reel from the mast.

REEL DISASSEMBLY

1. Remove the nuts from the hub studs and lift off the rotating cover. See Figure 10.
2. Disconnect the reel outer cable connector from the inner cable connector. See Figure 10.
3. Remove the four nuts and washers attaching the inner cable container to the inner reel flange. See Figure 10.
4. Scribe a mark on the inner cable housing and the inner reel flange to aid in alignment during reassembly. See Figure 10.
5. **RIGHT HAND REEL** (See Figure 7.)
 - a. Pull both flanges (with outer cable) off the hub studs. Rotate the flanges slightly to free the inner cable connector.
 - b. Remove the hub outer snap ring. See Figure 10.
 - c. Pull the hub off the shaft.
 - d. Leave the stud spacer and bracket on the hub. See Figure 11.

NOTE: Since the O-rings on the shaft produce friction, it may be necessary to tap gently on the end of the shaft with a rubber mallet or hammer handle while pulling on the hub.

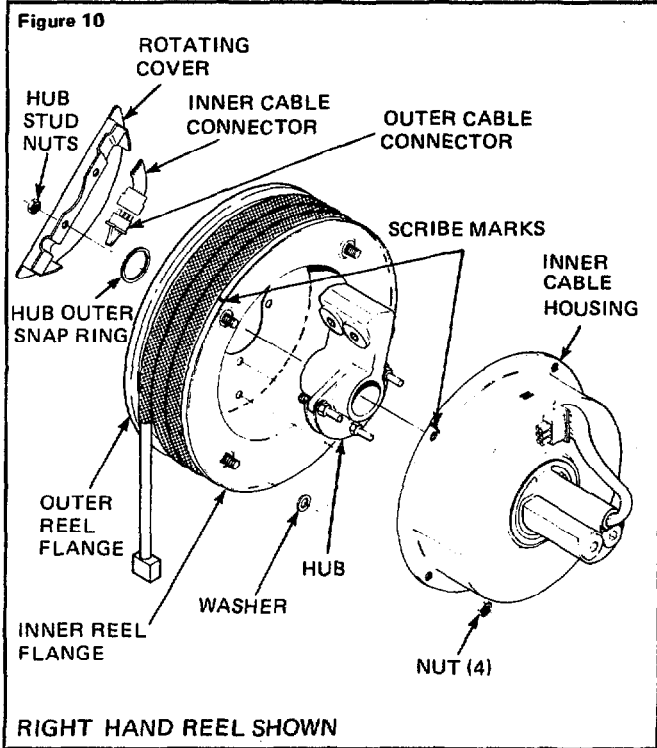

LEFT HAND REEL (See Figure 7.)

- a. Remove the hub outer snap ring.
 - b. Pull the hub off the shaft.
 - c. Remove both flanges (with outer cable) and the stud bracket.
6. Remove the worn seals and inner snap ring from the shaft.

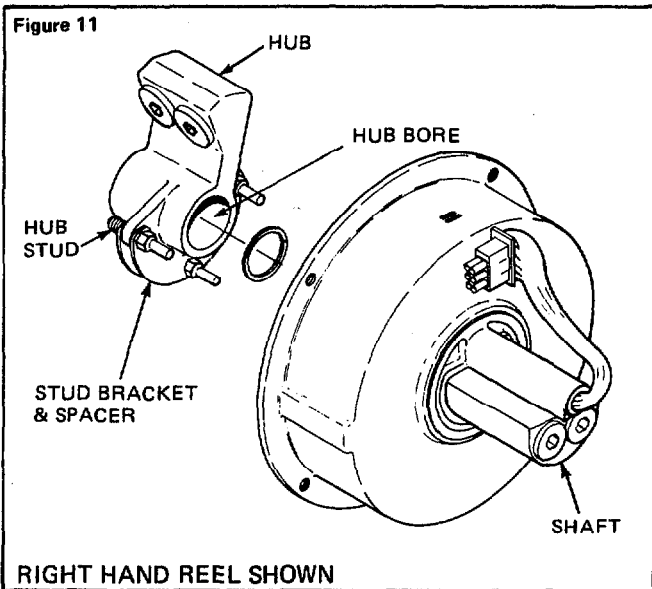

7. Inspect the seal grooves on the shaft. If sharp edges, nicks or projections are found use emery cloth (320 grit) to smooth up. See Figure 12. If imperfections cannot be removed from the critical sealing surfaces (metal surfaces O-rings seat against) shaft replacement may be necessary.

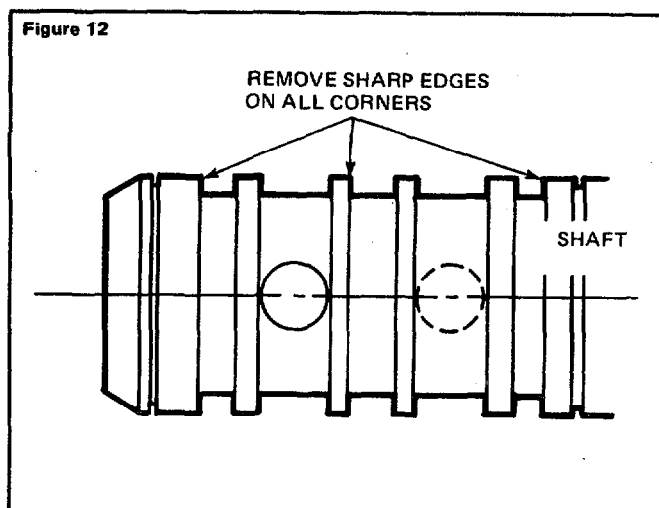

8. Inspect the hub bore. Use a brake hone (1½" recommended stone length) or butterfly hone (320 grit) and a light lubricant to clean the hub bore of **ALL** wear marks and sharp edges in the critical O-ring sealing areas. See Figure 13.

IMPORTANT: Do not drag the hone across the sealing surfaces when removing from the hub bore.

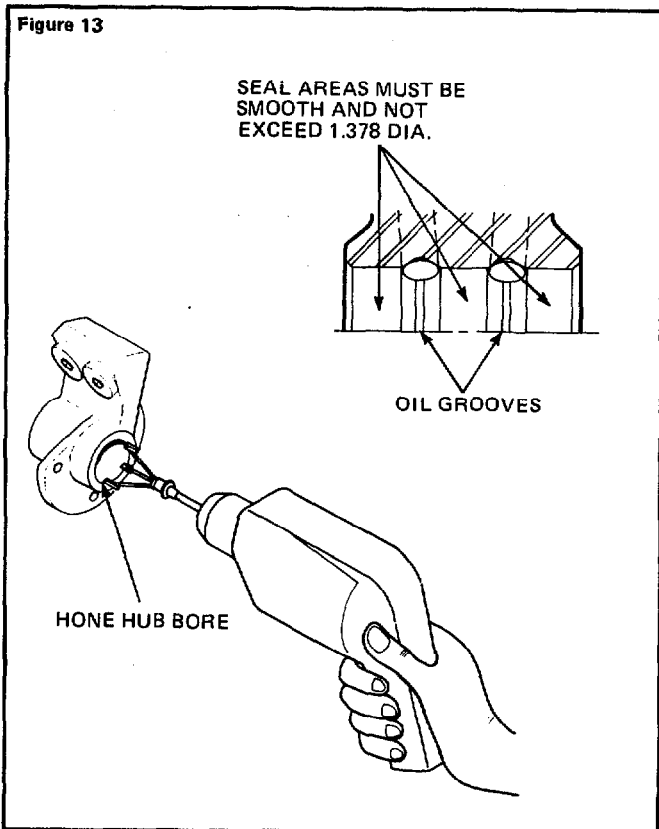

9. After honing, measure the inside diameter of the hub. The I.D. must not exceed 1.378 inches. If the diameter exceeds this dimension, premature seal leakage will occur. Hub replacement is recommended. See Figure 13.
10. Rinse the shaft and hub in a noncorrosive solvent to remove all traces of grit. Blow dry with compressed air.

SPRING ASSEMBLY REPLACEMENT

NOTE: If the spring assembly does not require replacement delete this step and proceed to Reel Reassembly.

1. Remove the hub inner snap ring located on the shaft. See Figure 14.
2. With a screwdriver, disengage the spring from the spring retainer on the shaft. See Figure 14.

CAUTION: Do not allow the inner cable housing to rotate independently of its hub. Damage to the inner cable will occur if they are rotated. Use tape or wire to hold both from rotating. See Figure 14. **If either has been rotated** refer to the **Inner Cable Housing Timing** instructions on page 9.

3. Hold the reel assembly by the outside of the inner cable housing over a work bench with the shaft downward. Tap the shaft end on the bench. Slide the spring assembly out of the inner cable housing and off the shaft.
4. If the spring retainer has been damaged remove the spring retainer snap ring and install a new spring retainer. See Figure 14.
5. Slide the new spring assembly onto the shaft. Secure the spring end on the spring retainer. Make sure the notch in the spring assembly is aligned with the inner cable. See Figure 14.
6. Install the hub inner snap ring.

REEL REASSEMBLY

1. Lubricate the shaft, seals, and bore of the hub with petroleum jelly, STP, or hydraulic oil.
2. Preset the white split back-up rings for correct size. Squeeze until the ends overlap 1 inch and hold there for 3 seconds. See Figure 15.

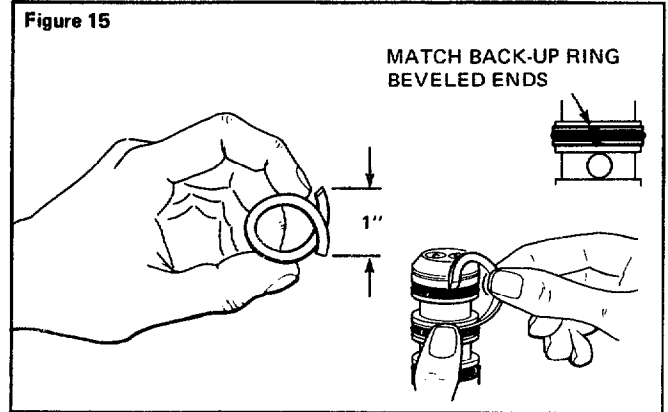

3. The white split back-up rings install in the center groove of the shaft. Install them by placing one end in the groove and winding it around the shaft. Inspect the ends for properly matched beveled edges. See Figure 15. Proper back-up ring placement is shown in Figure 16.

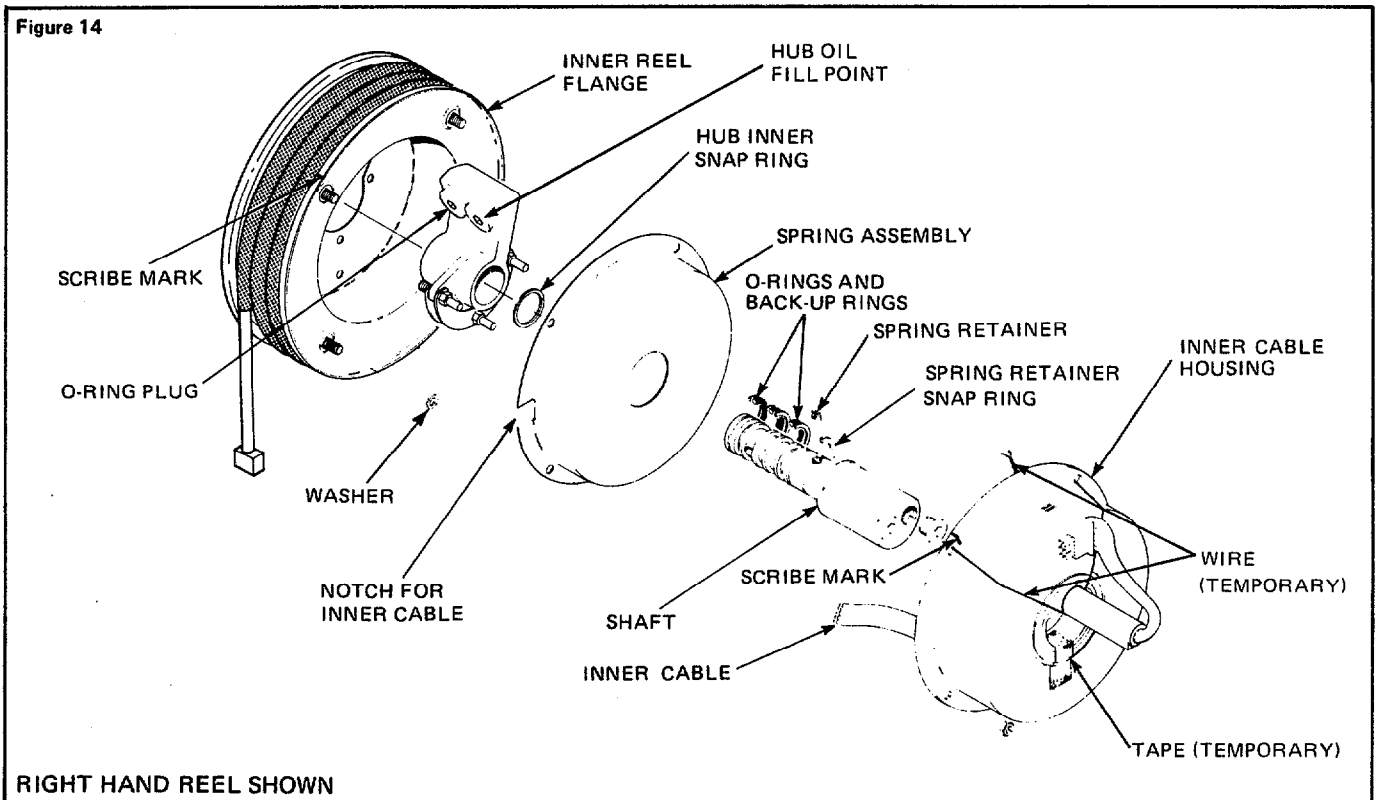
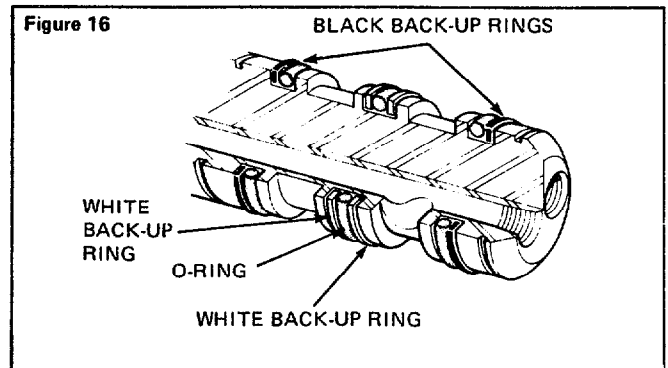

NOTE: It is important to load and deposit the black back-up rings individually and as quickly as possible.

4. The black back-up rings install in the two outer shaft grooves. Apply lubricant to the seal loader. Install one back-up ring at a time on the seal loader and deposit into its respective groove. See Figure 16 and 17. Allow the back-up rings to set in the shaft grooves about 5 minutes.

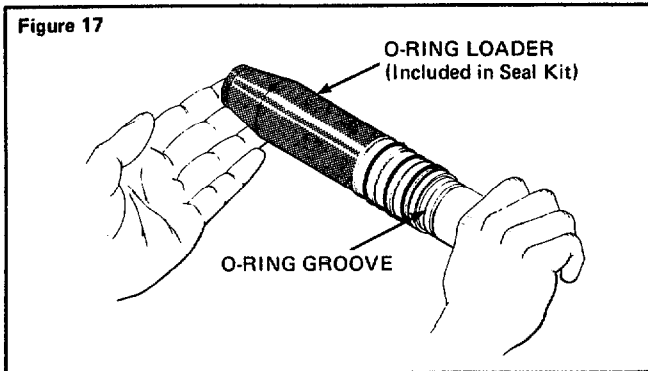

5. Slide the seal loader over the shaft to compress the seals. Lightly tap (do not rotate) the loader down the shaft to the inner snap ring. Leave on the shaft 10 minutes to thoroughly compress the seals.

NOTE: It is recommended, while servicing the inner cable housing or installing a new shaft seal kit, the cable harness (inside the inner cable housing) be lubricated with TRI-FLON spray lube, Cascade 669779. (See inner cable replacement section, page 8, for assembly instructions.)

6. RIGHT HAND REEL (See Figure 7.)

- a. Rotate the hub slowly as you slide it onto the shaft.
- b. Install the hub outer snap ring. See Figure 10.
- c. Fill hub to within 1/4" of O-ring plug with a 50/50 mixture of "STP" and hydraulic oil. See Figure 14.
- d. Place the reel flanges onto the hub, aligning the scribe mark on the inner cable container to the scribe mark on the inner reel flange.

LEFT HAND REEL (See Figure 7.)

- a. With the stud bracket and spacer on the inside of the reel flanges, slide the hub and reel flanges as one unit onto the shaft.
- b. Align the scribe mark on the inner cable container to the scribe mark on the reel flanges.
- c. Install the hub outer snap ring. See Figure 10.
- d. Fill hub to within 1/4" of O-ring plug with a 50/50 mixture of "STP" and hydraulic oil. See Figure 14.
7. Install the four capscrews, washers, and nuts as shown in Figure 10 and tighten the nuts.
8. Reconnect inner and outer cable connectors. See Figure 18.
9. Install the rotating cover and hub nuts. The inner cable must be laying flat in the flange depression and not pinched. Tighten the nuts to a torque of 70-75 in.-lbs.

10. Remount the reel to the truck at this time.
 - a. Reconnect the inner cable connector to the truck cable at the mounting block. See Figure 4.
 - b. Attach the clamp to the truck cable and secure the clamp to the mounting block. See Figure 4.
 - c. Install the fixed cover.

CAUTION: Overtightening the capscrews will damage the fixed cover.

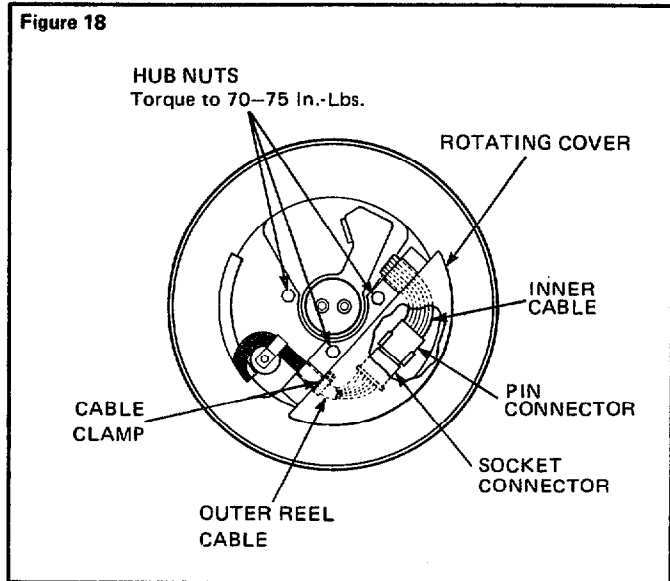

11. Make sure cable is tightly wound on reel in direction indicated (viewed from the flange side). See Figure 7.

Right Hand Reel: Cable wound clockwise.

Left Hand Reel: Cable wound counterclockwise.

12. Prewind the reel spring by grasping the end of the outer cable and turning the reel a minimum of 3 turns in the direction indicated (viewed from the flange side). See Figure 7.

Right Hand Reel: Wind reel clockwise.

Left Hand Reel: Wind reel counterclockwise.

CAUTION: Rotation in a direction opposite than described will damage the inner cable and reel spring.

If more tension is required the reel can be prewound additional turns. The maximum turn capacity is 16 turns.

Total turns = Prewind turns + Working turns.

CAUTION: Exceeding turn capacity of the reel will damage the inner cable and reel spring.

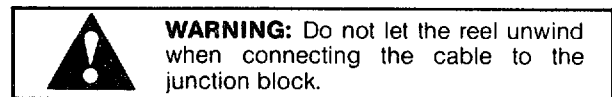

13. With the reel prewound, pull the cable end down to the junction block, loop once around the junction block and fasten securely with the cable clamp. See Figure 8.
14. Connect the attachment cable connector to the connector at the junction block.
15. Operate the carriage up and down a few times to make sure the cable tracks smoothly and no interference exists.

INNER CABLE REPLACEMENT

DISCONNECTING THE REEL

1. Disconnect connectors at junction block.
2. Remove the cable from the junction block.



WARNING: Hold cable firmly while disconnecting cable from the junction block. Allow the reel spring to unwind slowly while maintaining tension on the loose cable end. See Figure 19.

Figure 19

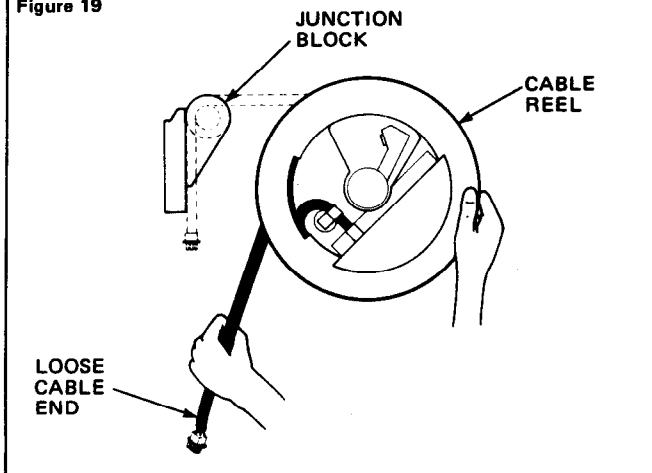

3. Remove the fixed cover from the mounting block and disconnect the cable connector. See Figure 4.
4. Remove the capscrews and lockwashers fastening the reel to the mounting pad. Remove the reel from the mast.

REEL DISASSEMBLY

1. Remove the nuts from the hub studs and lift off the rotating cover. See Figure 20.
2. Disconnect the reel outer cable connector from inner cable connector. See Figure 20.
3. Remove the four nuts and washers attaching the inner cable housing to the inner reel flange. See Figure 20.
4. Pull the reel flanges off the hub studs. Rotate the flanges slightly to free the inner cable connector.
5. Remove the mounting brackets and split the mounting blocks from the shaft. See Figure 20.
6. Separate the spring assembly from the inner cable housing. Slide the inner cable housing off the shaft. See Figure 20.

CAUTION: Do not allow the inner cable housing to rotate independently of its hub. Damage to the inner cable will occur if they are rotated. Use tape or wire to hold both from rotating. If either has been rotated refer to the **Inner Cable Housing Timing** instructions on page 9.

Figure 20

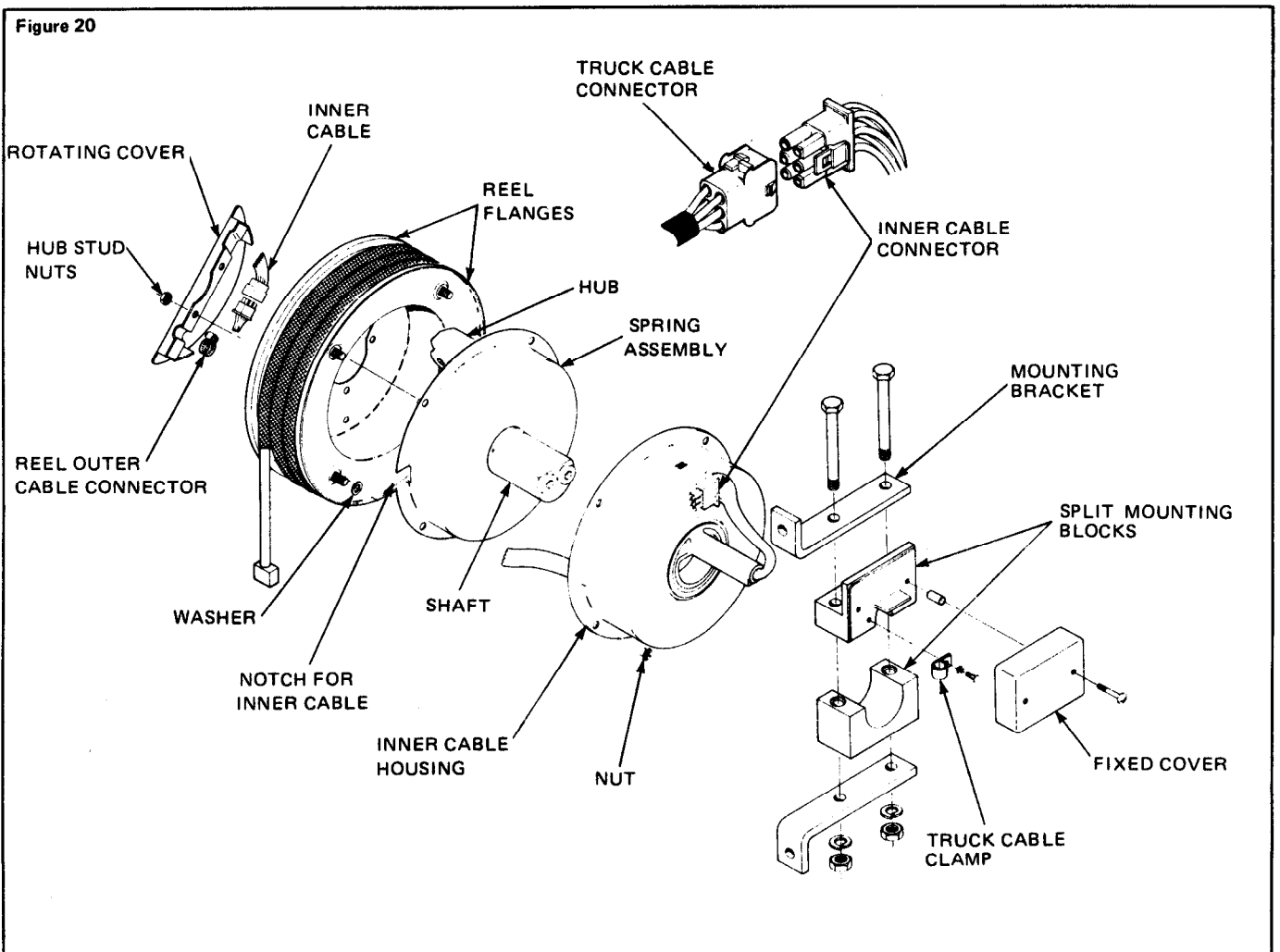

INNER CABLE REPLACEMENT

NOTE: If a new Inner Cable Housing is being installed, delete this step and proceed to Reel Reassembly.

1. Insert a small diameter allen wrench under the lip of the divider plate. Grip the allen wrench with a pair of vise grips. Pull outward to remove the divider plate. See Figure 21.

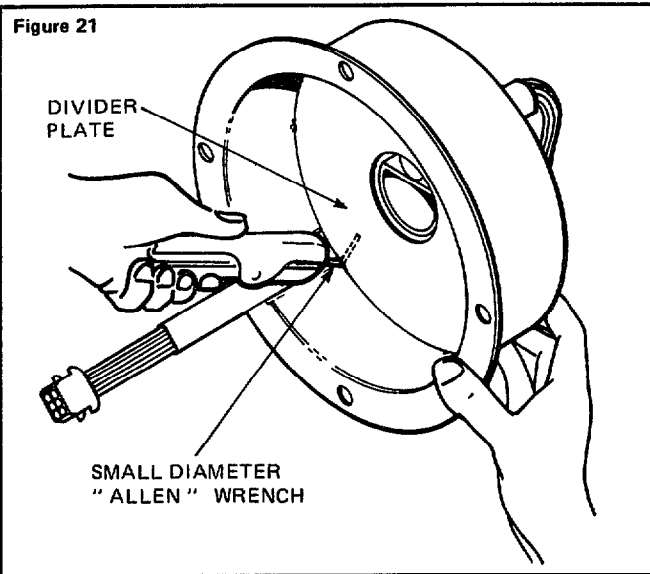

2. Remove the cable harness.
3. Place the new cable harness in the housing. Fit the cable (at its 90° bend) under the spring plate and around the pin. See Figure 22.

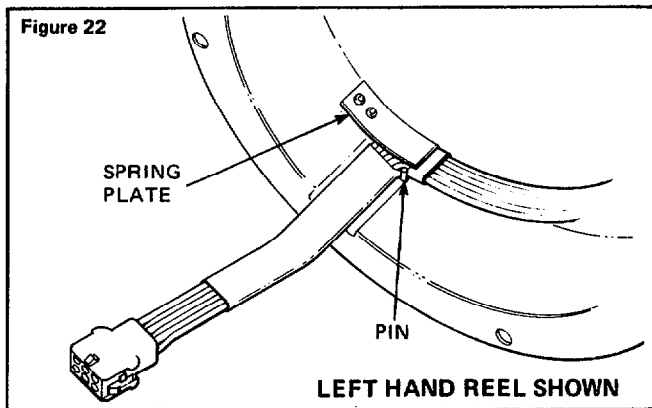

4. Wind the cable around the hub in the direction shown in Figure 23.
A Right or Left hand reel is determined as viewed from the flange side of the reel. See Figure 7.

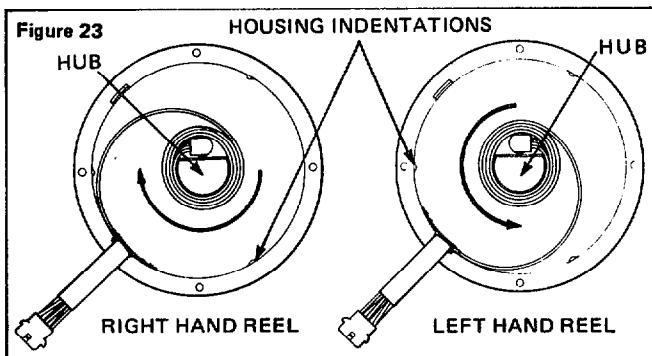

5. Place the divider plate inside the housing. Push the plate edge past the three housing indentations.

INNER CABLE HOUSING TIMING

1. Determine if the reel is a right hand or left hand model as viewed from the flange side of the reel. See Figure 7.
2. Position the cable container with the hub cable harness toward you. See Figure 24.
3. Hold the housing from rotating. Wind the hub until tight:
Right Hand Reel: Wind hub counterclockwise.
Left Hand Reel: Wind hub clockwise.
4. Rotate the hub back 1 revolution. This provides one safety turn in the wiring to prevent internal damage.
5. Use tape or wire to secure the hub to the housing. This will prevent either from rotating. The Inner Cable Housing is ready for further reel assembly.

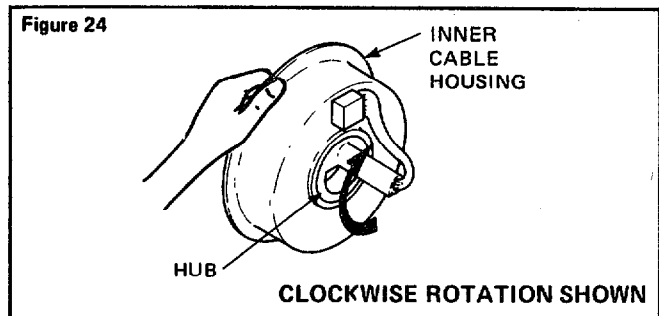

REEL REASSEMBLY

1. Fit the new inner cable housing over the shaft (do not rotate) and over the spring assembly. Be sure to fit the inner cable into the notch in the spring assembly. See Figure 20.

CAUTION: Do not allow the inner cable housing to rotate independently of its hub. Damage to the inner cable will occur if they are rotated. Use tape or wire to hold both from rotating. **If either has been rotated** refer to the **Inner Cable Housing Timing** instructions above.

IMPORTANT: The spring assembly must be in its neutral position when fitted into the inner cable housing.

2. Install the split mounting blocks and mounting brackets. See Figure 20.
3. Fit the reel flanges onto the hub studs. Install the capscrews, washers, and nuts to fasten the reel flanges to the inner cable housing.
4. Connect inner and outer cable connectors.
5. Install the rotating cover and hub nuts. The inner cable must be laying flat in the flange depression and not pinched. Tighten the nuts.
6. Remount the reel on the truck.
7. Reconnect the inner cable connector to truck cable at mounting block. See Figure 20.
8. Attach the clamp to the truck cable and secure the clamp to the mounting block.

TROUBLESHOOTING GUIDE

PROBLEM	PROBABLE CAUSE	CORRECTIVE ACTION
Excessive wear on cable.	Cable reel and junction block are not in proper alignment.	Align the junction block and cable reel properly. They must be on the same center line and mounted squarely to each other. See Figure 5.
	Cable reel flanges damaged.	Repair or replace damaged parts.
Cable jumps off reel during operation.	Incorrect prewind of spring.	Prewind spring, see page 7.
	Cable not aligned with junction block.	Align junction block with cable reel. See Figure 5.
Cable binds during operation.	Cable reel spring is broken.	Replace the spring.
	Back-up ring on hub shaft working between shaft and hub.	Replace the back-up rings.
	Scored seal areas.	Replace the damaged hub and/or use an emery cloth to remove the nicks from the shaft.
Electrical malfunction.	The same pattern for cable connections has not been used at all locations.	Make sure pin and cable connectors use the same pattern at all locations.
	Electrical short in the reel cable, truck or attachment cable.	See Electrical Troubleshooting Guide.
Inner Cable Housing wire breaks inside housing.	Excessive mast height.	Cable reel cannot be used in this application. The maximum turn capacity is being exceeded.
	Cable reel wound backwards.	Replace Inner Cable Housing. Wind reel in direction indicated in Inner Cable Housing Replacement Instructions.
	Service life of wire has been exceeded.	Replace Inner Cable Housing.

2168h

ELECTRICAL TROUBLESHOOTING GUIDE

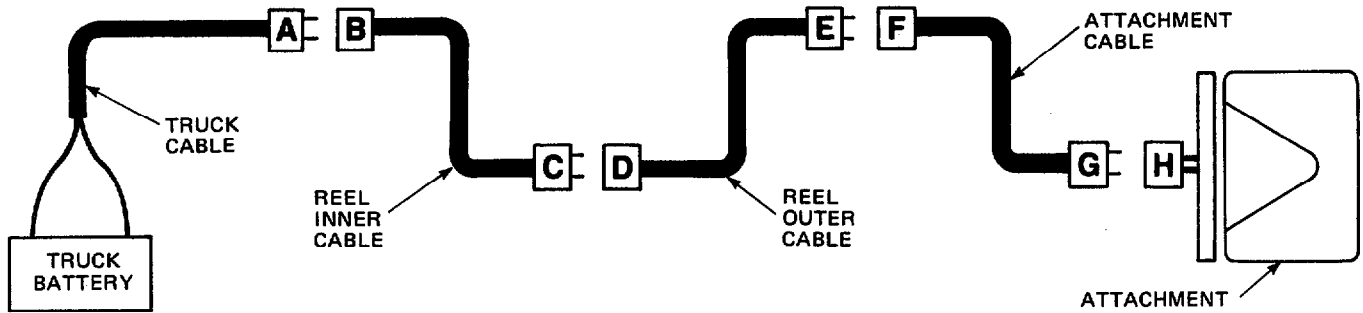

Using the accompanying electrical diagram and the following instructions, locate an electrical short. When using an ohmmeter to check for continuity, follow the instructions with your meter. Make sure that electrical power is disconnected when checking continuity.

1. Connect cable connector A to cable connector F (to isolate the entire cable reel). Operate the attachment.

NOTE: Do not operate the mast.

- a. If the attachment does not operate at all:

- disconnect cable connector A from cable connector F.
- with an ohmmeter, check the continuity of the attachment cable (between connectors F and G). If the cable checks OK, the truck cable is faulty and should be replaced. Refer to your truck Service Manual.

- b. If some attachment functions respond and others do not, the pins and/or sockets in the connectors are at fault and should be replaced. Recheck attachment operation after repair.

- c. If all attachment functions operate correctly, reconnect the cables as shown in the diagram and proceed to Step 2.

2. Connect cable connector A to cable connector D (to isolate the reel inner cable). Operate the attachment.

NOTE: Do not operate the mast.

- a. If the attachment does not operate at all, the reel outer cable is faulty and should be replaced. For replacement instructions, refer to page 10.

- b. If some attachment functions respond and others do not, the pins and/or sockets in the connectors are at fault and should be replaced. Recheck attachment operation after repair.

- c. If all attachment functions operate correctly, reconnect the cables as shown in the diagram and proceed to Step 3.

3. Connect cable connector C to cable connector F (to isolate the reel outer cable). Operate the attachment.

NOTE: Do not operate the mast.

- a. If the attachment does not operate at all, the reel inner cable is faulty and should be replaced. For replacement instructions, refer to page 8.

- b. If some attachment functions respond and others do not, the pins and/or sockets in the connectors are at fault and should be replaced. Recheck attachment operation after repair.

CABLE LENGTH CALCULATIONS

H=Total lift height

D=Distance from centerline of reel to junction block.

1. When "**H**" is equal to, or greater than 2 X "**D**" the correct cable length is:
"**H**" - "**D**" + 28 inches
2. When "**H**" is less than 2 X "**D**" the correct cable length is:
"**D**" + 28 inches

Example

"**H**"=286"

"**D**"= 96"

286"-96"=190" + 28"=218"

correct cable length

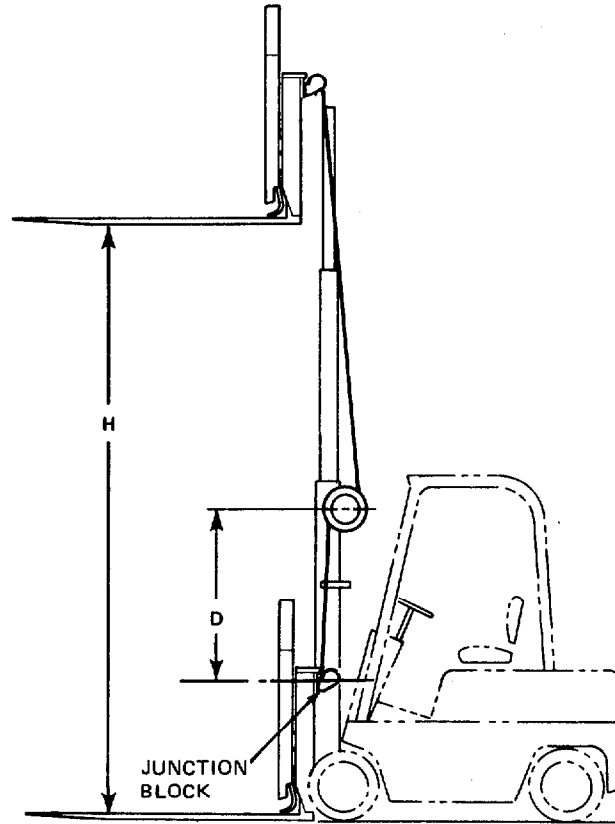

WORKSHEET

1. H =(enter mast's lift height here)	_____	If line 1. is equal to or larger than line 3., the cable length should be
2. D =(enter distance between junction block and center of reel with carriage completely lowered)	_____	H (line 1.) _____
3. Multiply " D " by 2	_____	+ D (line 2.) _____
4. If line 1. is less than line 3., the cable length should be	_____	= _____
D (line 2.)	_____	+ 28 inches 28"
+ 28 inches	28"	Cable Length = _____
Cable Length =	_____	

See page 14 for standard cable length.

JUNCTION BLOCK GROUP

REF	QTY	PART NO.	DESCRIPTION
		662377	Junction Block Group
1	1	662378	Junction Block
2	1	662379	Clip
3	2	3601	Capscrew
4	2	6288	Lockwasher

2168k

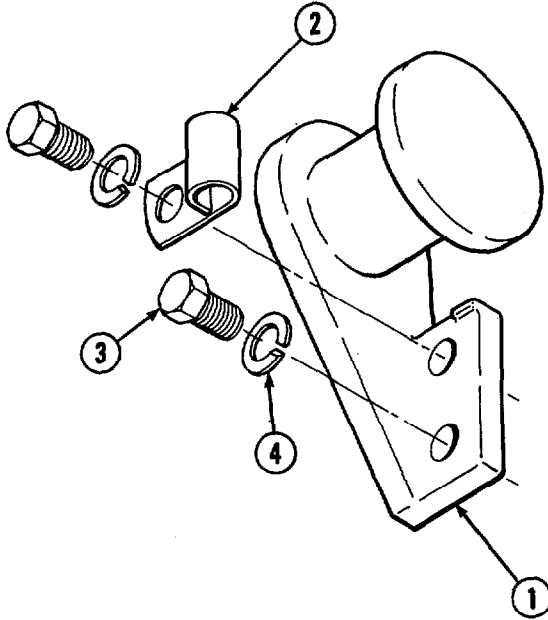

MOUNTING GROUP

REF	QTY	RIGHT HAND PART NO.	LEFT HAND PART NO.	DESCRIPTION
		665330	665331	Mounting Group
1	1	664084	664085	Mounting Bracket
2	3	6288	6288	Lockwasher
3	3	3601	3601	Capscrew
4	2	6290	6290	Lockwasher
5	2	5904	5904	Nut
6	1	662293	662293	Bar

2168k

These mounting groups designed for Cascade roller triple lift masts.
For Cascade Quad masts and masts other than Cascade, use Mounting Group 661031.
See page 15.

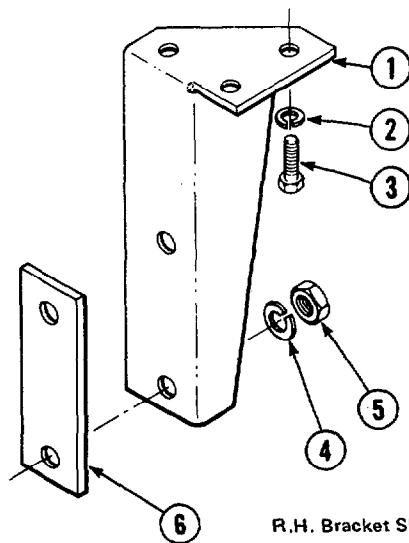

R.H. Bracket Shown

CABLE GROUPS

CATALOG ORDER NO.	CABLE LENGTH
662383	196"
663011	276"

2168k

CABLE REEL PARTS

15

RIGHT HAND REEL SHOWN

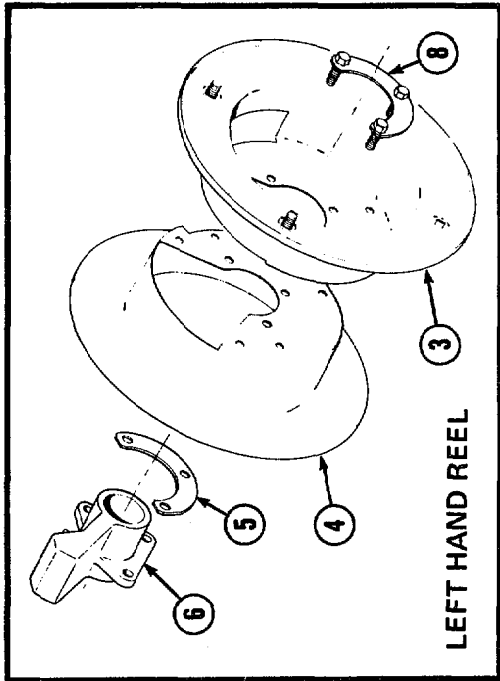
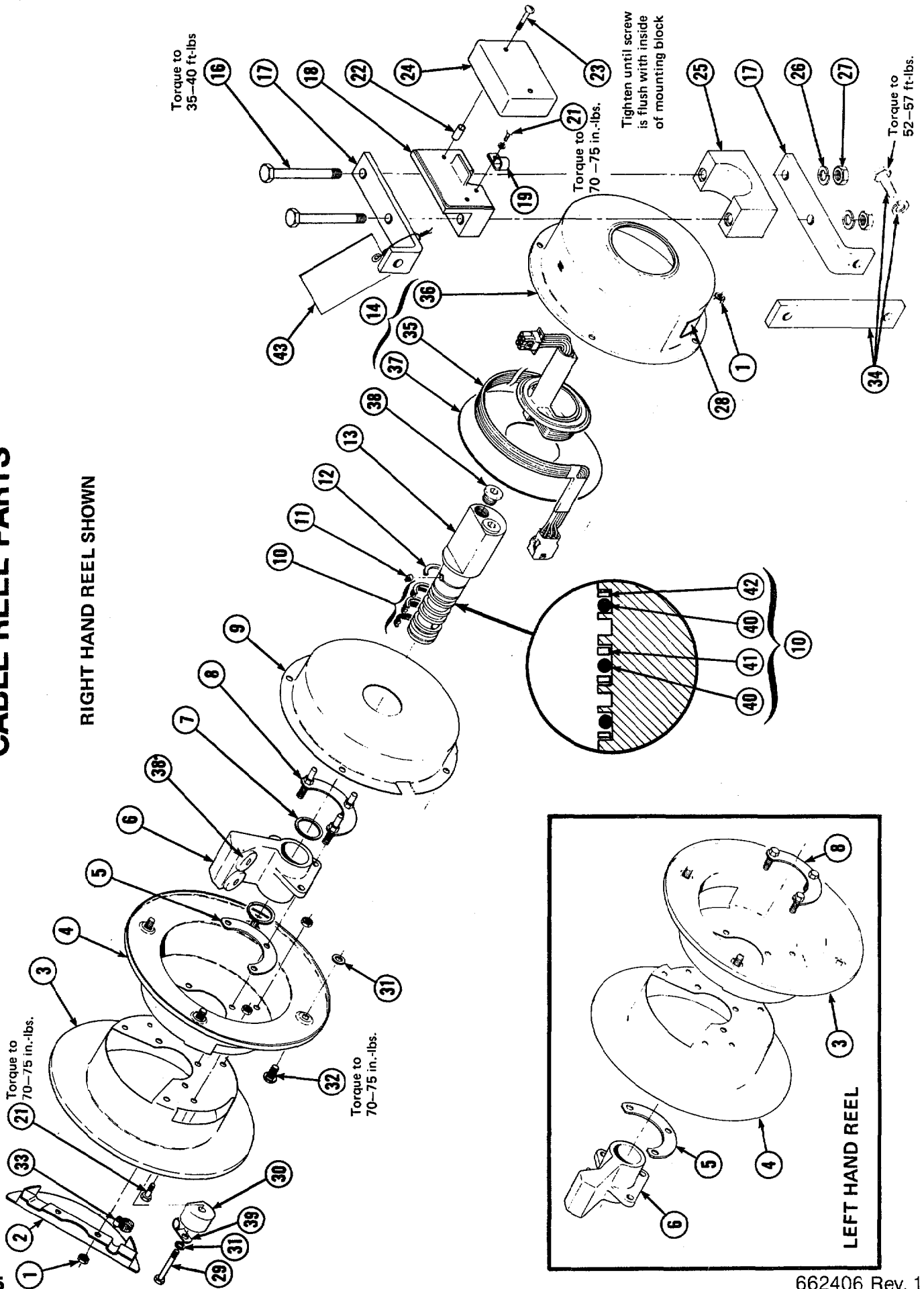

CABLE REEL PARTS

REF	QTY	PART NO.	DESCRIPTION	REF	QTY	PART NO.	DESCRIPTION
		669713	Cable Reel Assembly - Right Hand	21	4	3551	Capscrew, 1/4 NC x .50
		669714	Cable Reel Assembly - Left Hand	22	2	663886	Tube
		★662407	Cable Reel Assembly - Right Hand	23	2	659887	Machine Screw
		★662408	Cable Reel Assembly - Left Hand	24	1	659886	Fixed Cover
1	11	645986	Locking Nut, 1/4 NC	25	1	659884	Lower Mounting Block
2	1	659898	Rotating Cover - Left Hand	26	2	6290	Lockwasher
3	1	659876	Rotating Cover - Right Hand	27	2	5904	Nut, 1/2 NC
4	1	645979	Flange	28	1	669715	Nameplate
5	1	645990	Flange	29	1	3557	Capscrew, 1/4 NC, 1.50
6	1	659880	Spacer	30	1	662381	Cable Guide
7	2	646064	Hub	31	5	6228	Washer
8	1	7194	Snap Ring	32	4	659889	Capscrew
9	1	659881	Bracket	33	1	659875	Clamp
10	1	664886	Spring Assembly - Right Hand	34	1	661031	Mounting Kit
11	1	664885	Spring Assembly - Left Hand	35	1	669654	Cable Harness
12	1	646339	Shaft Seal Kit	36	1	669647	Cable Housing Assembly - Right Hand
13	1	659917	Spring Retainer	37	1	669648	Cable Housing Assembly - Left Hand
14	1	653314	Snap Ring	38	4	602580	Divider Plate
15	1	659879	Shaft	39	1	655071	Plug
16	1	669651	Cable Service Kit - Right Hand	40	3	654926	Clip
17	1	669652	Cable Service Kit - Left Hand	41	2	648569	O-Ring
18	2	660414	Connector Kit	42	2	671754	Back-up Ring - White
19	2	3667	Capscrew, 1/2 NC x .50	43	1	667898	Back-up Ring - Black
20	1	659888	Mounting Bracket	43	1	667898	Caution Tag
		659885	Upper Mounting Block	‡		676314	Service Kit
		659890	Clip				
		6286	Lockwasher				

21681

- Included in Shaft Seal Kit (646339) with O-Ring Loader.
- + Connector Kit includes 1 Socket Connector Housing (661680) and 6 Socket Connectors (661681); 1 Pin Connector Housing (661678) and 6 Pin Connectors (661679).
- Included in Cable Service Kit.
- ★ No longer available as an assembly.
- ‡ Includes (1) crimping tool and (1) pin extractor tool.

Do you have questions you need answered right now? Call your nearest Cascade Service Department.

AMERICAS

**Cascade Corporation
U.S. Headquarters**
2201 NE 201st
Fairview, OR 97024-9718
Tel: 800-CASCADE (227-2233)
Fax: 888-329-8207

Cascade Canada Inc.
5570 Timberlea Blvd.
Mississauga, Ontario
Canada L4W-4M6
Tel: 905-629-7777
Fax: 905-629-7785

Cascade do Brasil
Rua João Guerra, 134
Macuco, Santos - SP
Brasil 11015-130
Tel: 55-13-2105-8800
Fax: 55-13-2105-8899

EUROPE-AFRICA

**Cascade Italia S.R.L.
European Headquarters**
Via Dell'Artigianato 1
37030 Vago di Lavagno (VR)
Italy
Tel: 39-045-8989111
Fax: 39-045-8989160

Cascade (Africa) Pty. Ltd.
PO Box 625, Isando 1600
60A Steel Road
Sparton, Kempton Park
South Africa
Tel: 27-11-975-9240
Fax: 27-11-394-1147

ASIA-PACIFIC

Cascade Japan Ltd.
2-23, 2-Chome,
Kukuchi Nishimachi
Amagasaki, Hyogo
Japan, 661-0978
Tel: 81-6-6420-9771
Fax: 81-6-6420-9777

Cascade Korea
121B 9L Namdong Ind.
Complex, 691-8 Gojan-Dong
Namdong-Ku
Inchon, Korea
Tel: +82-32-821-2051
Fax: +82-32-821-2055

Cascade-Xiamen
No. 668 Yangguang Rd.
Xinyang Industrial Zone
Haicang, Xiamen City
Fujian Province
P.R. China 361026
Tel: 86-592-651-2500
Fax: 86-592-651-2571

**Cascade India Material
Handling Private Limited**
No 34, Global Trade Centre
1/1 Rambaugh Colony
Lal Bahadur Shastri Road,
Navi Peth, Pune 411 030
(Maharashtra) India
Phone: +91 020 2432 5490
Fax: +91 020 2433 0881

Cascade Australia Pty. Ltd.
1445 Ipswich Road
Rocklea, QLD 4107
Australia
Tel: 1-800-227-223
Fax: +61 7 3373-7333

Cascade New Zealand
15 Ra Ora Drive
East Tamaki, Auckland
New Zealand
Tel: +64-9-273-9136
Fax: +64-9-273-9137

**Sunstream Industries
Pte. Ltd.**
18 Tuas South Street 5
Singapore 637796
Tel: +65-6795-7555
Fax: +65-6863-1368

