



Technical Bulletin

Bonded Rubber Contact Pads Edge Reduction for Cascade Paper Roll Clamps

This sheet describes how to widen the front edge chamfer of a Cascade bonded smooth or RXH rubber contact pad for Cascade Paper Roll Clamps. Cascade recommends using a grinder with 24-grit sanding disc. A finer grit disc can be used but may cause smoke and take longer to achieve results. Grind the rubber to widen the front edge until one inch or greater is achieved.

NOTE: To remove adhesive labels, such as UPC stickers, use a fine wire brush.

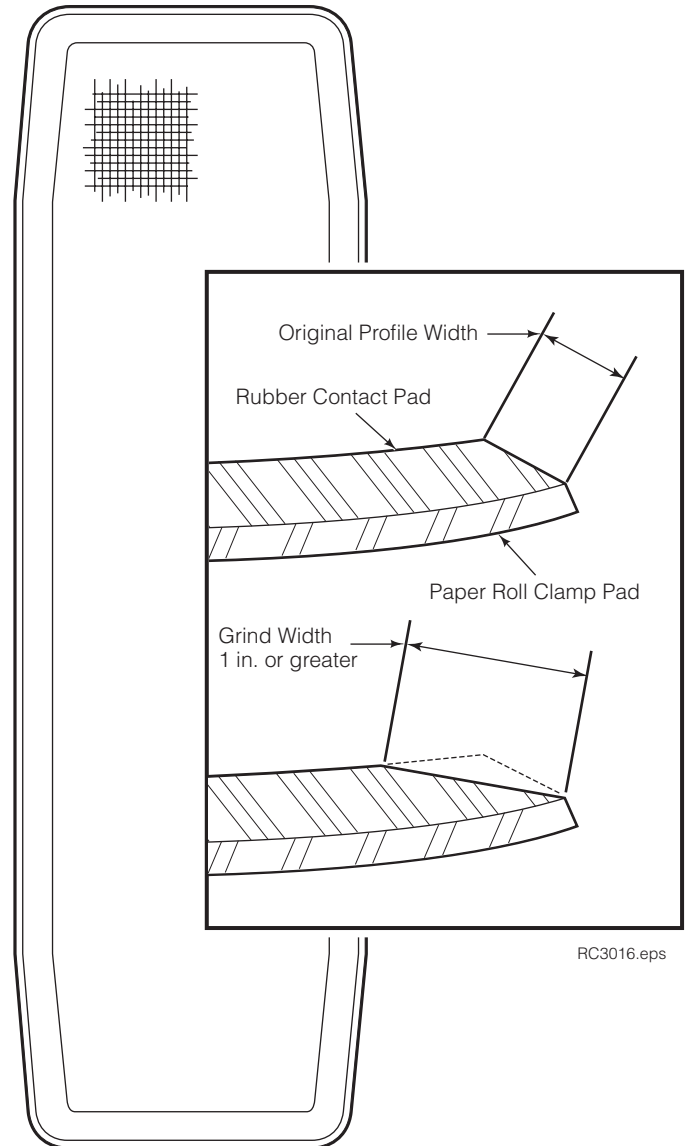

NOTE: This information should not be interpreted as the basis for warranty claims unless so designated.

cascade[®]
corporation

For Technical Support . . .

Call: 1-800-CASCADE (227-2233)

OR

Write: Cascade Corporation, PO Box 20187, Portland, OR 97294-0187

To Order Parts . . .

Call: 1-888-CASCADE (227-2233)

OR

Write: Cascade Corporation, 2501 Sheridan Ave., Springfield, OH 45505