



Technical Bulletin

Filling the Fork Loading Slot on Cascade Carriages

When a Cascade Sideshifter with special 11.8 in. (300 mm) stroke is installed on a Cascade mast with a 31 in. wide carriage, the fork loading slot on the lower carriage bar should be filled. When the sideshifter is completely positioned to the right, the sideshifter left hand lower hook moves into alignment with the fork loading slot, losing its positive engagement with the lower carriage bar. To remedy the situation, a filler block must be welded in the fork loading slot.

- 1 Measure the mast carriage width:
 - If the carriage width **is greater than 31 in.**, no problem exists.
 - If the carriage width **is 31 in.**, continue with the following steps.
- 2 Locate the serial number on the sideshifter:
 - If the serial number **is not listed** below, no problem exists.
55E-SS-454
55E-SS-482
55E-SS-495
 - If the serial number **is listed**, continue with the following steps.
- 3 Weld one of the filler blocks listed below in the carriage fork loading slot.

Filler Block Part Number	Length
389416	3.75 in. (95 mm)
389117	5.12 in. (130 mm)

Weld using E-7018 low hydrogen 5/32 in. (4 mm) electrodes. Use reverse polarity or an AC welding machine set at 145-225 amps. Do not use electrodes exposed to moisture without first re-drying them at 200° F (75° C) for 2 hours. Do not oscillate or use a wash bead pattern. Let the welds slow cool.

- 4 Remove weld slag and inspect the welds. Clean the weld area and repaint.
- 5 Adjust the sideshifter lower mounting hooks up tight against the lower carriage bar then back off one rib position. Tighten the capscrews to a torque of 120 ft.-lbs. (165 Nm).

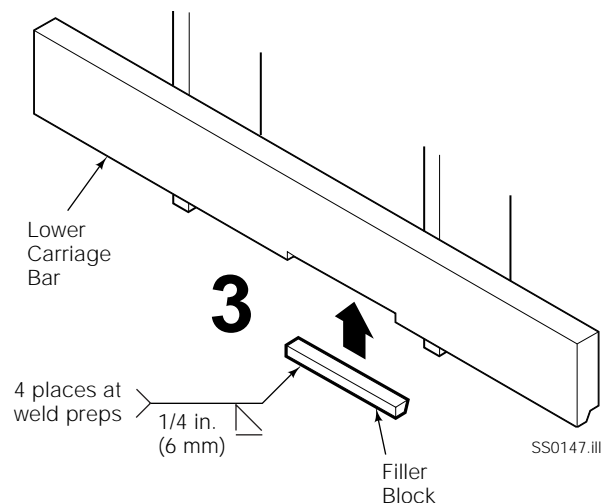
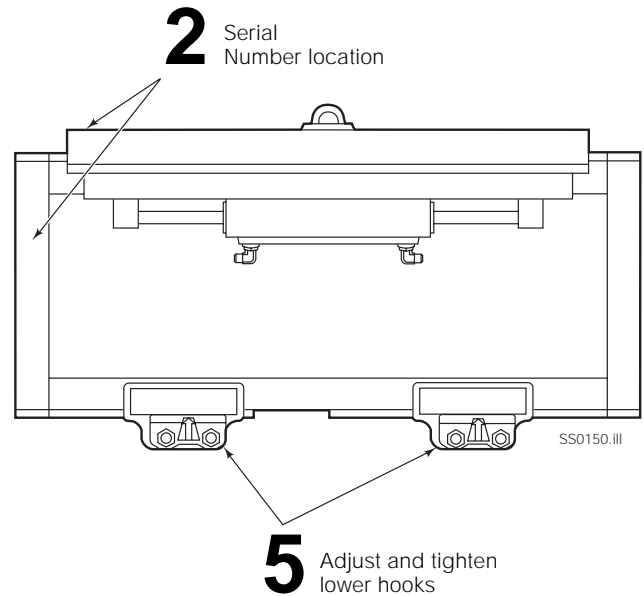

NOTE: This information should not be interpreted as the basis for warranty claims unless so designated.

cascade®

For Technical Support . . .

Call: 1-800-227-2233

OR

Write: Cascade Corporation, P.O. Box 20187, Portland, OR 97220

To Order Parts . . .

Call: 1-888-227-2233

OR

Write: Cascade Corporation, 2501 Sheridan Ave., Springfield, OH 45505

IMPORTANT: If the sideshifter is removed and forks installed on the mast carriage, the stops at the ends of the lower carriage bar must be removed. After the forks are installed on the carriage, a backrest must be installed to retain the forks. When not using a backrest, bolt-on stop bars (part no. 215635) must be installed to retain the forks.

