



Installation Instructions

Conversion to 5-in. (122 mm) Forks for K-Series Fork Positioners. Kit 6054753

This Instruction Sheet provides instructions to convert K-Series Fork Positioners from 4-in. forks to 5-in. forks by installing wider inner fork retainers and cylinder rod spacer collars. (Retrofit Kit 6054753.)

- 1** Position fork carriers to mid-stroke and remove bolt-on narrow inner fork retainers. Remove forks if installed.
- 2** Remove cylinder rod anchor plugs and slide fork carriers inward to expose split-ring keepers (see detail). Remove keepers.
- 3** Slide outer fork carriers outward to clear cylinder rods approximately 2 in. (50 mm). Install spacer collars on cylinder rods. **NOTE:** Spacers necessary to prevent over-stroking when closing with 5-in (122 mm) forks.
- 4** Slide outer fork carriers inward and reinstall split-ring keepers and anchor plugs. Use grease to hold split-rings in place. Tighten anchor plugs to 50 ft.-lbs. (65 Nm).
- 5** Install 5-in (122 mm) forks and slide into position on outer fork carriers.
- 6** Install new wide inner retainers and tighten capscrews to 25 ft.-lbs. (35 Nm).

REMOVING/INSTALLING FORKS

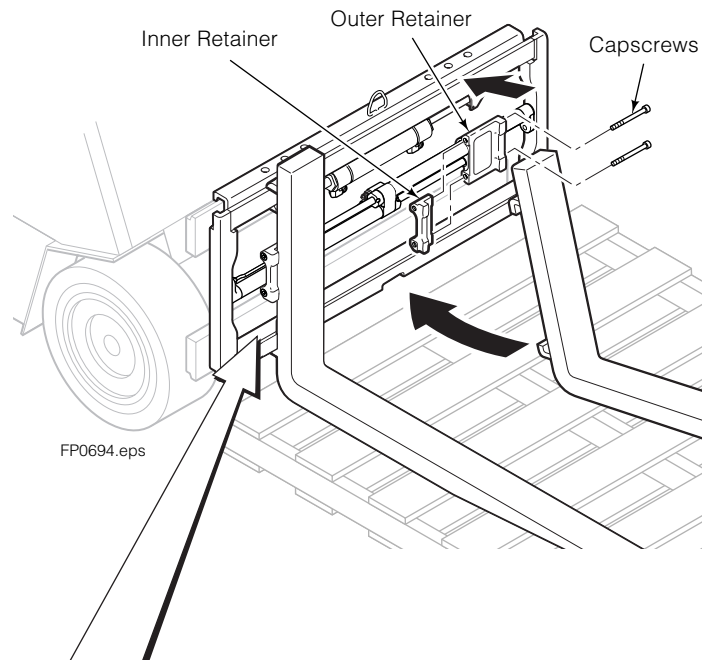

| REF | QTY | PART NO. | DESCRIPTION |
|-----|-----|----------|----------------------------------|
| | | 6054753 | Fork Conversion Kit |
| 1 | 2 | 6052301 | Fork Carrier, Inner, 122 mm Fork |
| 2 | 2 | 6054755 | Spacer Collar |

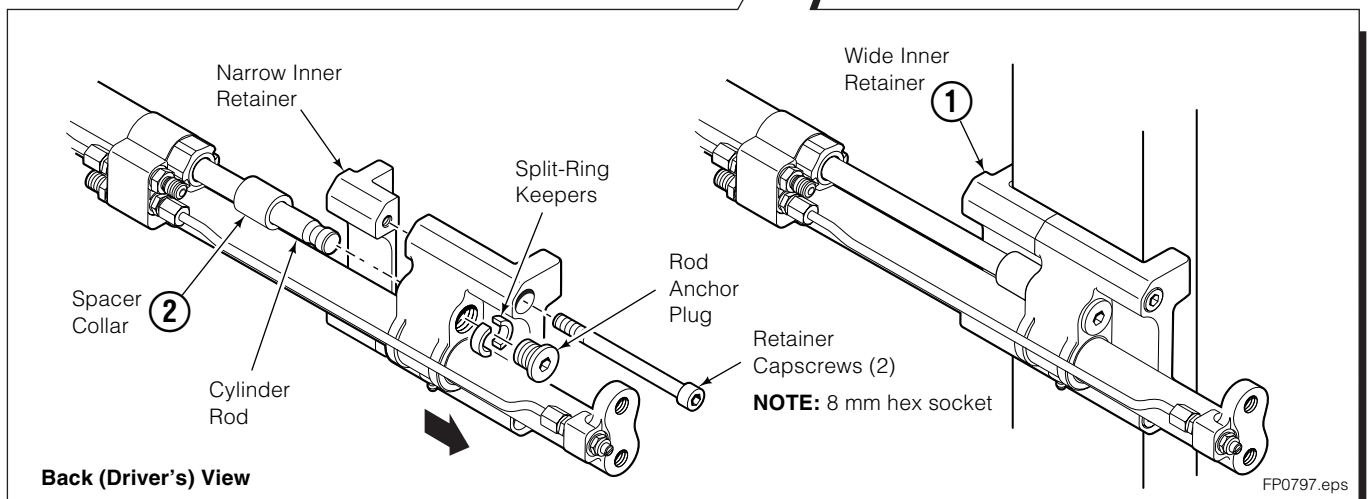

cascade[®]
corporation

For Technical Support . . .

Call: 1-800-227-2233 Fax: 1-888-329-8207
 Internet: www.cascorp.com
 Write: Cascade Corporation, PO Box 20187, Portland, OR 97294

To Order Parts . . .

Call: 1-888-227-2233 Fax: 1-888-329-0234
 Internet: www.cascorp.com
 Write: Cascade Corporation, 2501 Sheridan Ave., Springfield, OH 45505