



Technical Bulletin

45C Quad Viewmast® II Inner Upright Modifications to Accept New Style Cylinder Assemblies

This sheet describes procedures to modify the mast inner upright to accept replacement cylinders with a new style hydraulic inlet port.

- 1 Remove the old cylinder from the mast. Refer to service manual part no. 669223, Section 5.1-5.
- 2 Grind or burn off the corner of the horizontal plate flush with the front surface of the vertical plate just above it.
- 3 Install the new cylinder then reassemble and adjust the mast as described in the service manual.
- 4 Raise and lower the mast through several cycles to check for interferences and correct operation.

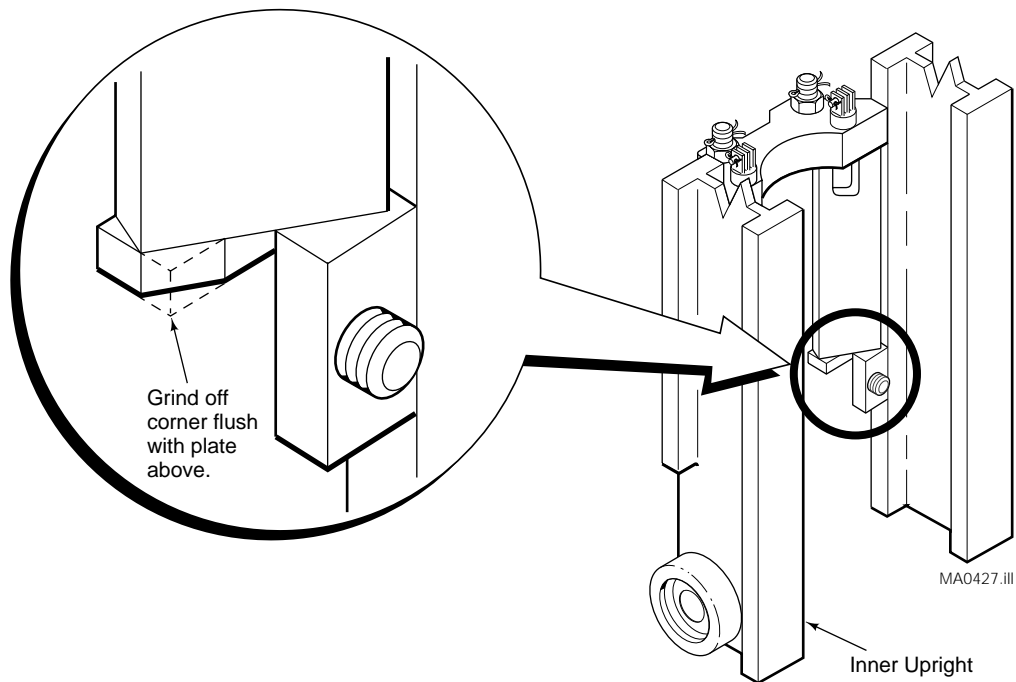

NOTE: This information should not be interpreted as the basis for warranty claims unless so designated.

cascade®

For Technical Assistance and to Order Parts . . .

Call: 1-800-CASCADE (227-2233) or 503-669-6300

FAX: 503-669-6367

Write: Cascade Corporation, PO Box 20187, Portland, OR 97220

© Cascade Corporation 1997