

Technical Bulletin

35C, 55C, 80C Dual Mast Outer Upright Stop Block Service Kits

This sheet provides instructions for the installation of Service Kits 680081 (35C), 680082 (55C) and 680083 (80C). The original stop block design has been obsoleted and replaced by these service kits.

1. Remove the original stop block from the outer upright top crossmember and discard.
2. Align the template (part no. 680096) included in the Service Kit on the top of the crossmember. Note the front and side of upright references. Center punch at the hole centers on the template.

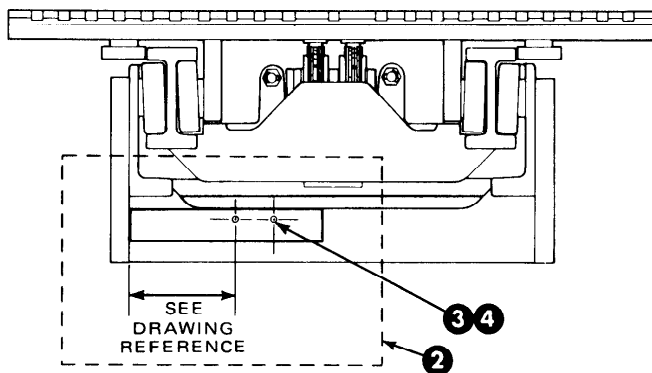

3. Drill two 3/8 in. pilot holes through the crossmember. Use of a portable magnetic base drill press is highly recommended.
4. Redrill pilot holes using drill diameter shown below.

35C	5/8 in. dia.
55C/80C	3/4 in. dia.

5. Install the new stop block using the capscrews and nuts supplied. Tighten to a torque of:

35C	100-120 ft.-lbs.
55C/80C	200-220 ft.-lbs.

NOTE: This information should not be interpreted as the basis for warranty claims unless so designated.
Part No. 680547

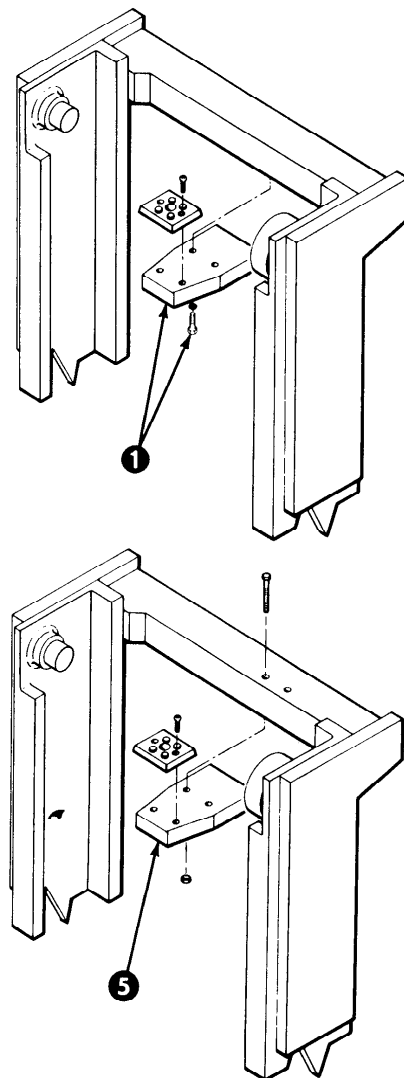

cascade[®]

For Technical Assistance . . .

Call/ 1-800-CASCADE or 503-669-6300

OR

Write: Cascade Corporation, P.O. Box 20187, Portland, OR 97220

To Order Parts . . .

Call: 513-322-1199

OR

Write: Cascade Corporation, P.O. Box 360, Springfield, OH 45505

