



# Installation Instructions

## Mark 55 Radio Frequency (RF) Hydraulic Control Kit 6076088 and Conversion Kit 6080195

This sheet provides installation instructions and replacement parts list for Cascade Hydraulic Control Kit 6076088 and Cascade Conversion Kit 6080195. The kits provide two function operation using a single function hydraulic supply and radio frequency (RF) solenoid actuation to select the push/pull or platen adjustment functions. The attachment mounted solenoid is battery powered and driver activated by a remote transmitter mounted on the truck. For installing the conversion kit, refer to pages 2 through 4.

**CAUTION:** If the truck or attachment will be cleaned with a pressure washer, remove the battery and receiver from the attachment prior to cleaning. High pressure water can damage the battery and receiver.

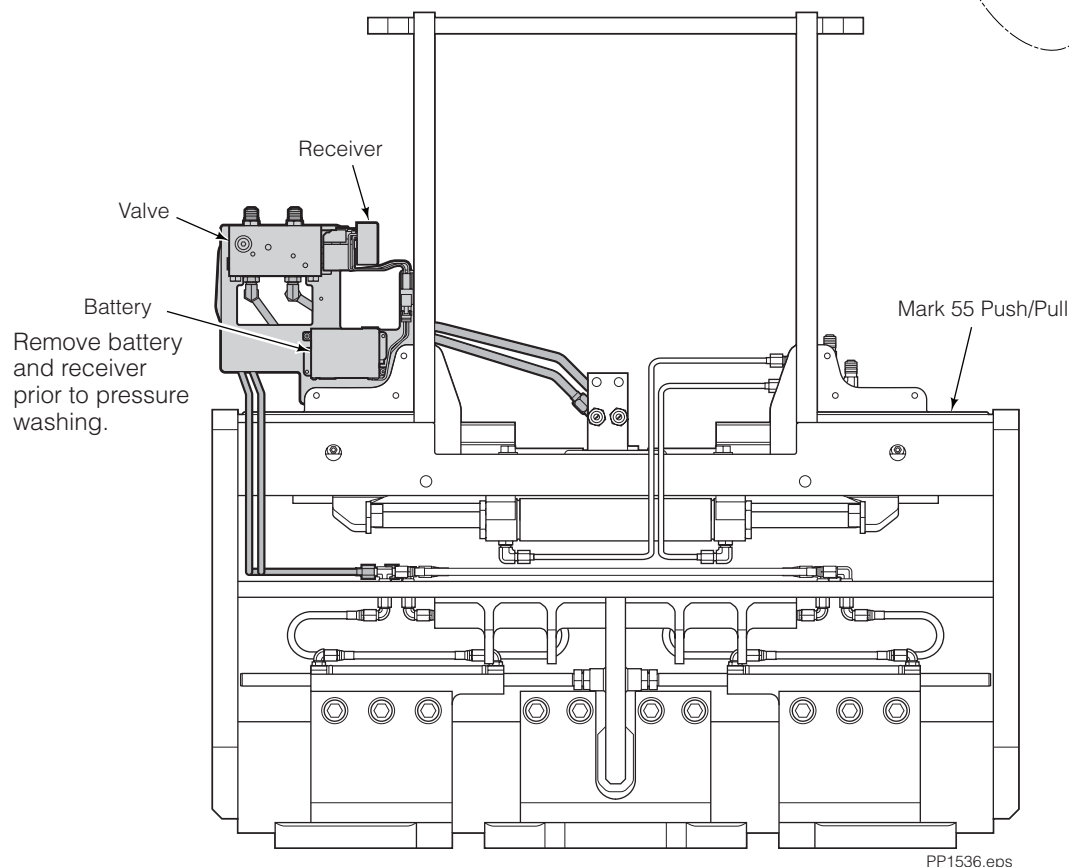
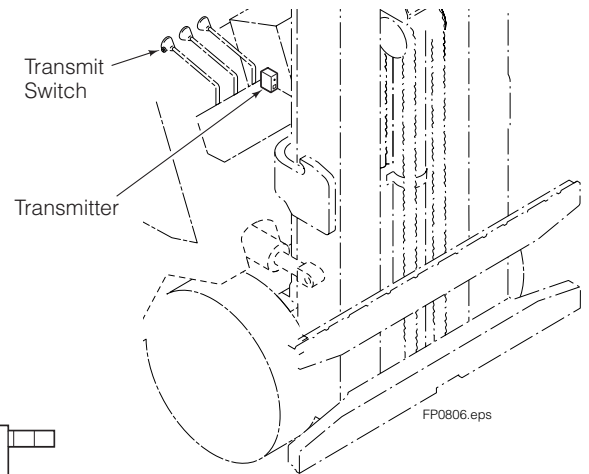

**cascade**<sup>®</sup>  
**corporation**

**For Technical Support . . .**

Call: 1-800-227-2233 Fax: 1-888-329-8207  
Internet: [www.cascorp.com](http://www.cascorp.com)  
Write: Cascade Corporation, PO Box 20187, Portland, OR 97294

**To Order Parts . . .**

Call: 1-888-227-2233 Fax: 1-888-329-0234  
Internet: [www.cascorp.com](http://www.cascorp.com)  
Write: Cascade Corporation, 2501 Sheridan Ave., Springfield, OH 45505

## Conversion Kit 6080195 Installation

The following instructions describe how to install the Radio Frequency Hydraulic Control kit. The kit includes new valve, tubes, brackets, receiver, transmitter, battery, and battery charger.



**WARNING:** Before removing any hoses, relieve pressure in the hydraulic system. With the truck off, open the truck auxiliary control valve(s) several times in both directions.

**1** Remove existing solenoid valve(s), tubes, cables and brackets. If equipped, remove battery and receiver.

**2** Mount battery clip and receiver clip to bracket.

**IMPORTANT:** Mount battery clip with chamfered tab on top side.

**3** Mount bracket to attachment and tighten capscrews to 13-15 ft.-lbs. (18-20 Nm).

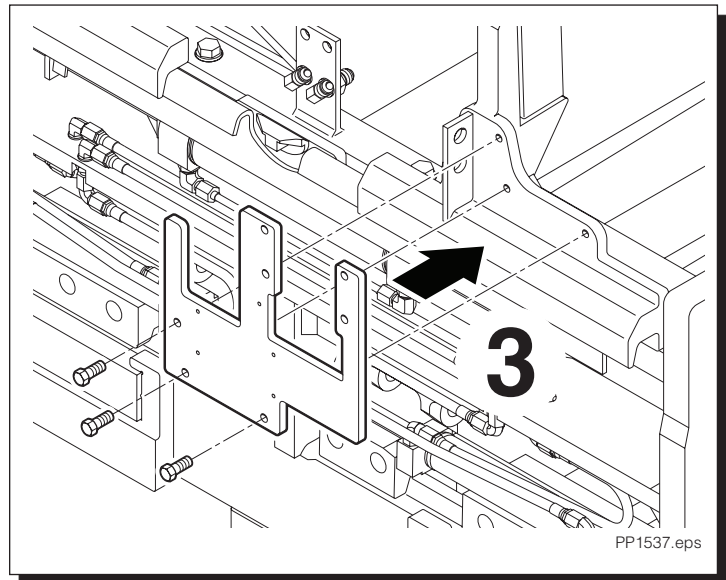
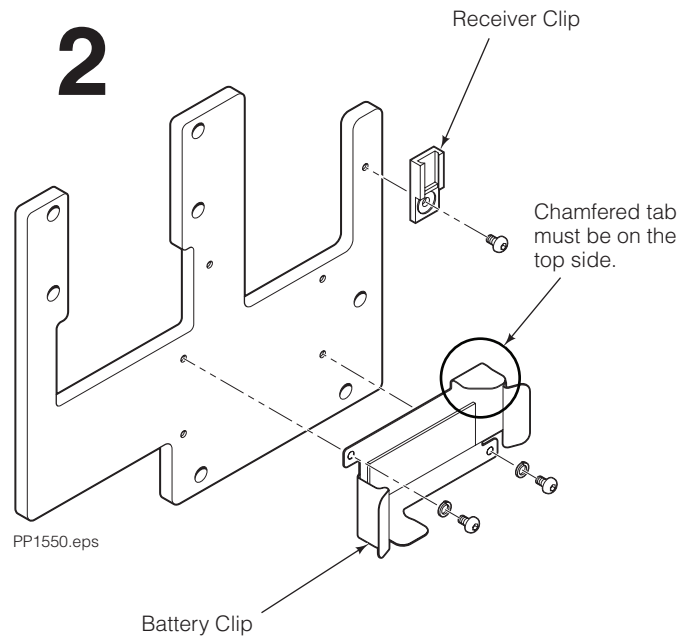

**4** Install fittings to the valve.

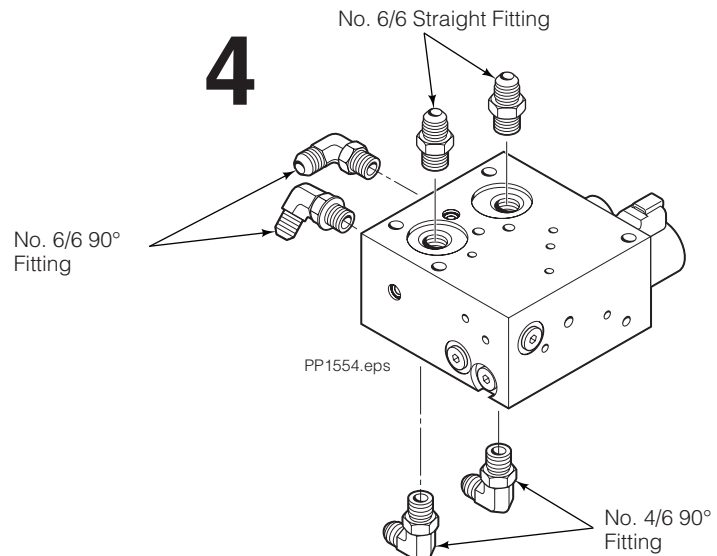

- 5** Mount valve to bracket and tighten capscrews to 13-15 ft.-lbs. (18-20 Nm).

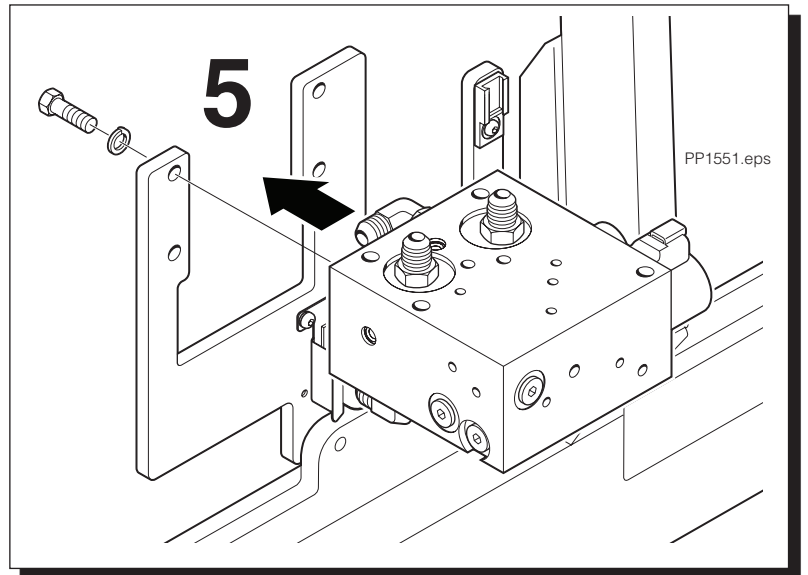

- 6** Install battery into battery clip.
- 7** Install receiver to valve solenoid. Connect receiver plug with battery plug.

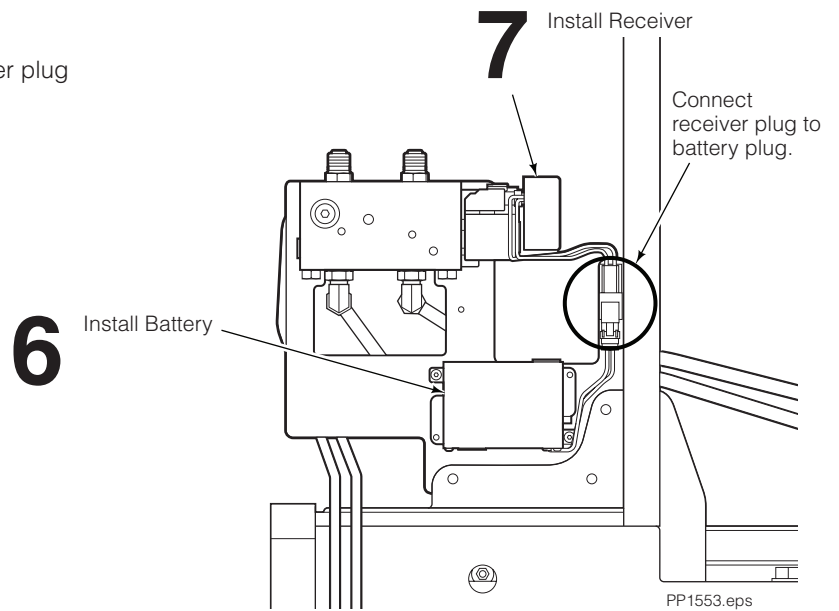

- 8** Install tubes and supply hoses.

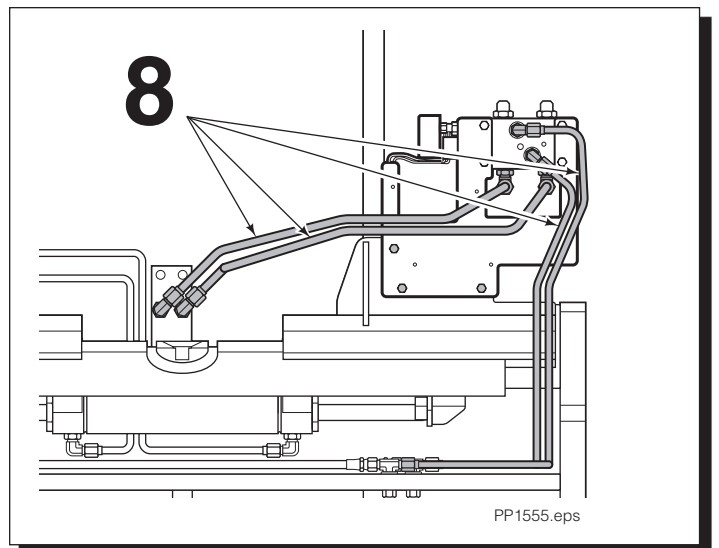

- 9** Install valve cover and tighten capscrews to 13-15 ft.-lbs. (18-20 Nm).

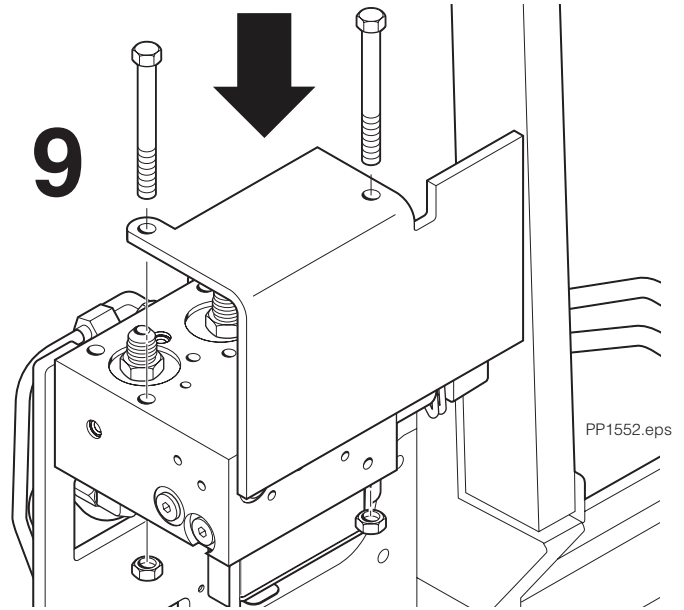

- 10** If kit includes knob, remove existing control knob from the Push/Pull auxiliary valve handle. Install the new knob using the adapter provided.

**CAUTION:** Secure the cable so it will not be pinched when the handle is actuated.

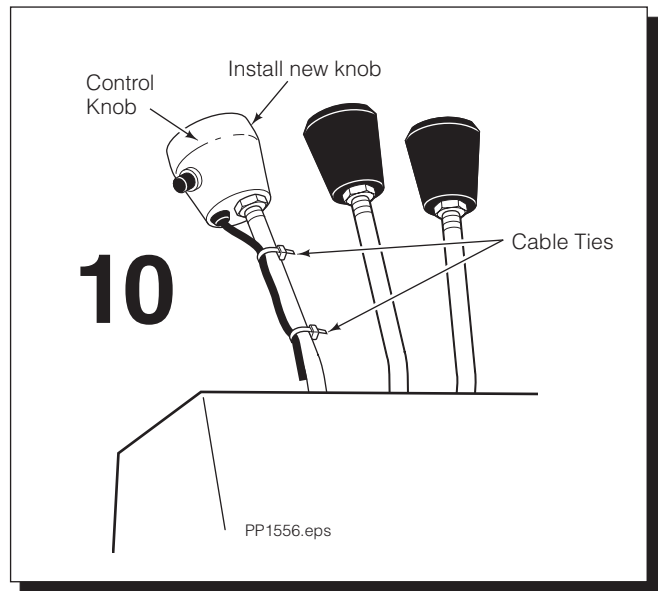

## Transmitter Installation

**1** Install the transmitter in an easy to view and accessible location for the driver. Provide at least 8 in. (20 cm) clearance between the driver and transmitter.

**IMPORTANT:** The transmitter must not be co-located or operating in conjunction with any other antenna or transmitter.

**2** Connect the transmitter red wire to a switched terminal on the truck fuse block. Connect the black wire to chassis ground. Connect the two remaining wires to a control knob transmit switch. Use Cascade Control Knob Kit 673130 or existing truck knob/switch (located on Push/Pull handle).

**IMPORTANT:** The resistor connected to the red wire is for use on trucks operating at 31V and higher. Remove the resistor on trucks operating at 30V or less.

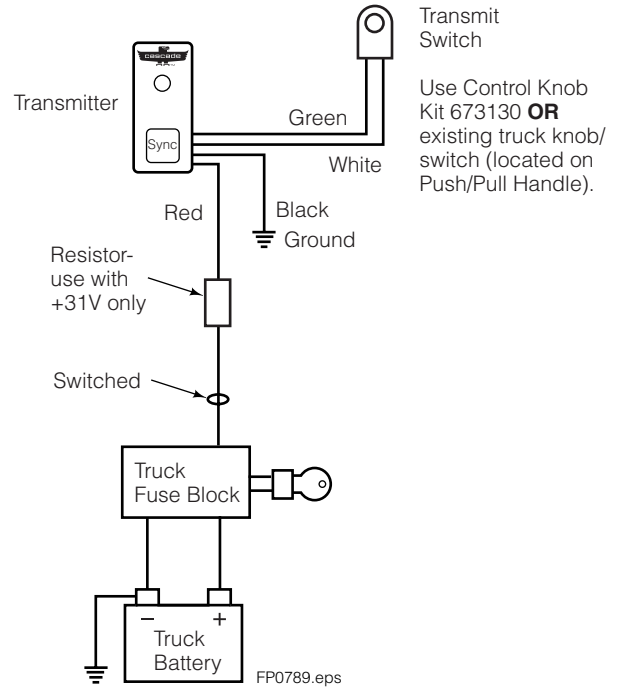

## Synchronizing Transmitter and Receiver

The transmitter and receiver have been synchronized at the factory. If resynchronizing is required, follow these steps:

**1** Press and hold the SYNC button on the transmitter for 3 seconds. The LED will begin to flash red and green.

**WARNING:** Do not reach through the mast to access the receiver SYNC button. Access the SYNC button from the front of the attachment.

**2** Within 15 seconds, press and hold the SYNC button on the receiver for 3 seconds. When the units are synchronized to each other, the flashing red and green LED will stop and the receiver will respond to the transmitter when the transmit switch is pressed.

## Operation

**Transmitter** – When the transmit switch is pressed, the LED on the transmitter will blink **green** every 1/2 second if there is communication between the transmitter and receiver. The solenoid coil clicks when the valve internal spool shifts.

The transmitter will blink **green** once a second if there is no communication with the receiver.

The transmitter LED will blink **red** once a second for a truck battery low condition.

After 1 hour of inactivity, the receiving unit goes into a sleep mode to conserve power. Press and hold the transmit switch button for 3 seconds to wake the unit for operation.

**Receiver** – The receiver will blink every 1/2 second when it is receiving a signal from the transmitter. The color of the blink changes with battery use.

The receiver LED blinks **green** when the battery is operating.

The receiver LED blinks **amber** for a short period when the battery is running low and needs to be charged.

The receiver LED blinks **red** for a short period when the battery needs to be charged and will not operate the fork positioner.

The transmitter and receiver operate in the frequency range of 915-928 Mhz @ .004 watts output for Australia and 902.2 –927.8 Mhz @ .004 watts output for all other locations.

## Battery

**NOTE:** Charge new batteries prior to use.

It is recommended to charge the battery after each shift to optimize the life of the battery. The light on the receiver indicates battery power level:

**Green** – Full usable power.

**Amber** – Low Power. Charge soon.

**Red** – No power. Recharge required.

**None** – No power. Recharge required.

Chargers available are listed.

Location	Battery Charger
	Part No.
USA	6079239
Americas	6079239
Europe	6079699
United Kingdom	6079701
Australia	6079697

# Hydraulic Control Kit

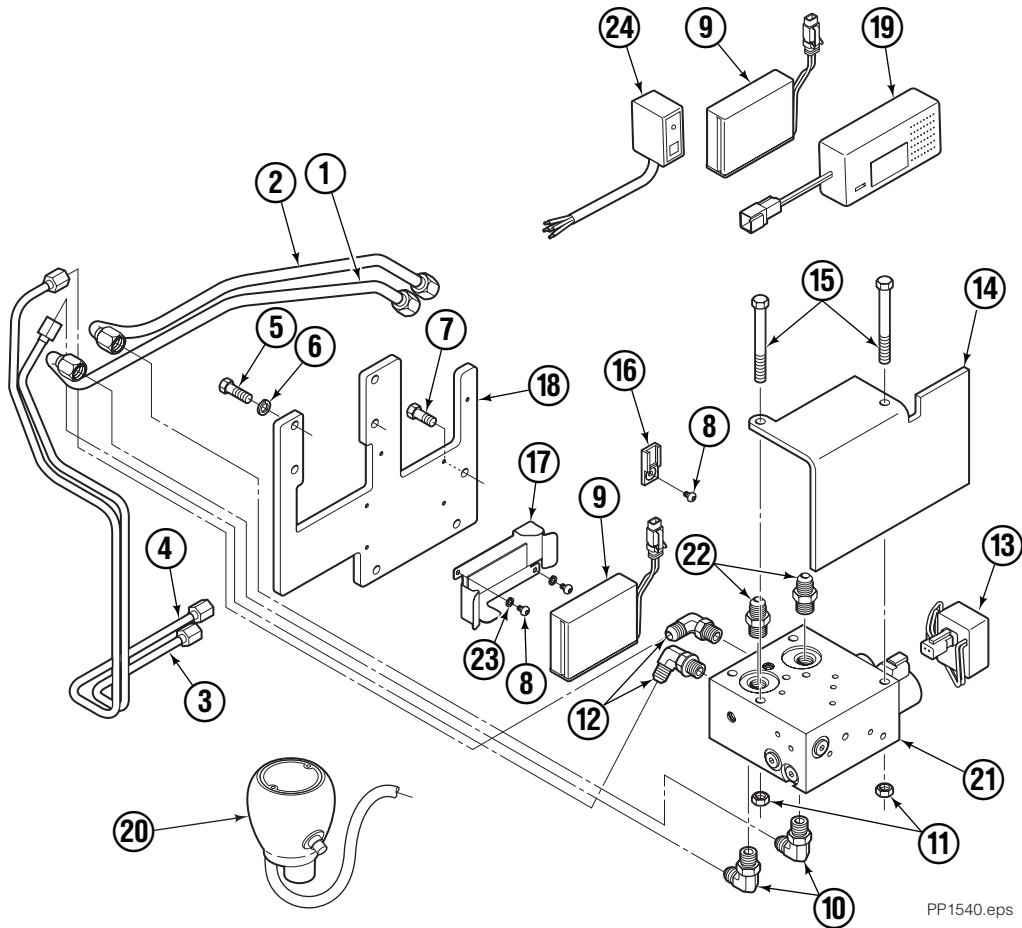

REF	QTY	PART NO.	DESCRIPTION	REF	QTY	PART NO.	DESCRIPTION
		6076088	RF Solenoid Adaption Kit	12	2	666984	Fitting, JIC No. 4-6 90° Elbow
		6080195	RF Solenoid Conversion Kit	13	1	6076160	Receiver ■
1	1	6079210	Tube Assembly	14	1	6080040	Valve Protection Bracket
2	1	6079209	Tube Assembly	15	2	6405022	Capscrew, M8 x 80
3	1	6079212	Tube Assembly	16	1	6079201	Receiver Clip
4	1	6079211	Tube Assembly	17	1	6079186	Battery Clip
5	4	787373	Capscrew, M8 x25	18	1	6079101	Bracket
6	4	787384	Lockwasher, M8	19	1	6079239	Battery Charger, Lithium Ion
7	3	787372	Capscrew, M8 x 20	20	1	355058	Knob Assembly ▲
8	3	6076098	Button Head Capscrew, M?	21	1	6070947	Valve Assembly ●
9	2	6075736	Battery	22	2	604511	Fitting, No. 6-6 Straight
10	2	601676	Fitting, No. 6-6 90° Elbow	23	2	685899	Lockwasher, M4
11	2	767414	Nut, M8	24	1	6053765	Transmitter ■

■ Included in RF Transmission Kit 6076165.

▲ Included with kit 6076088. See Knob Assembly page for parts breakdown.

● See Valve Assembly page for parts breakdown.

# Control Knob

## Two Function – Sideshift Only

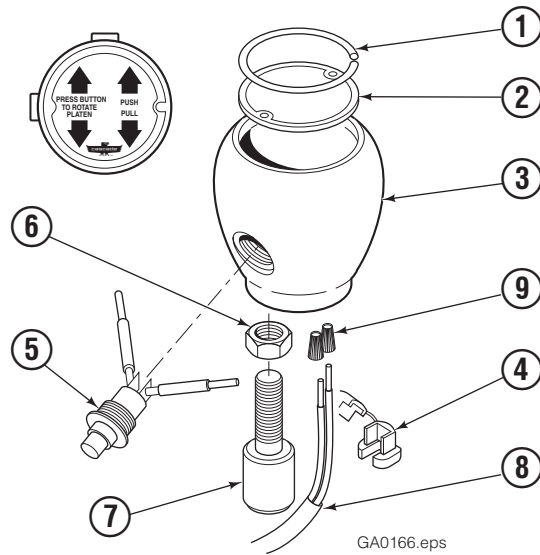

REF	QTY	PART NO.	DESCRIPTION
		355058	Knob Group
1	1	665250	Snap Ring
2	1	355059	Cover
3	1	665012	Knob
4	1	665076	Strain Relief
5	1	677112	Switch ■
6	1	5902	Nut, 3/8 NC
7	1	665081	Adaptor
8	1	667718	Cable Assembly
9	2	667752	Connector – Gray

■ This switch may be purchased without wires. Order part number 665004. Soldering is required.

# Valve Assembly

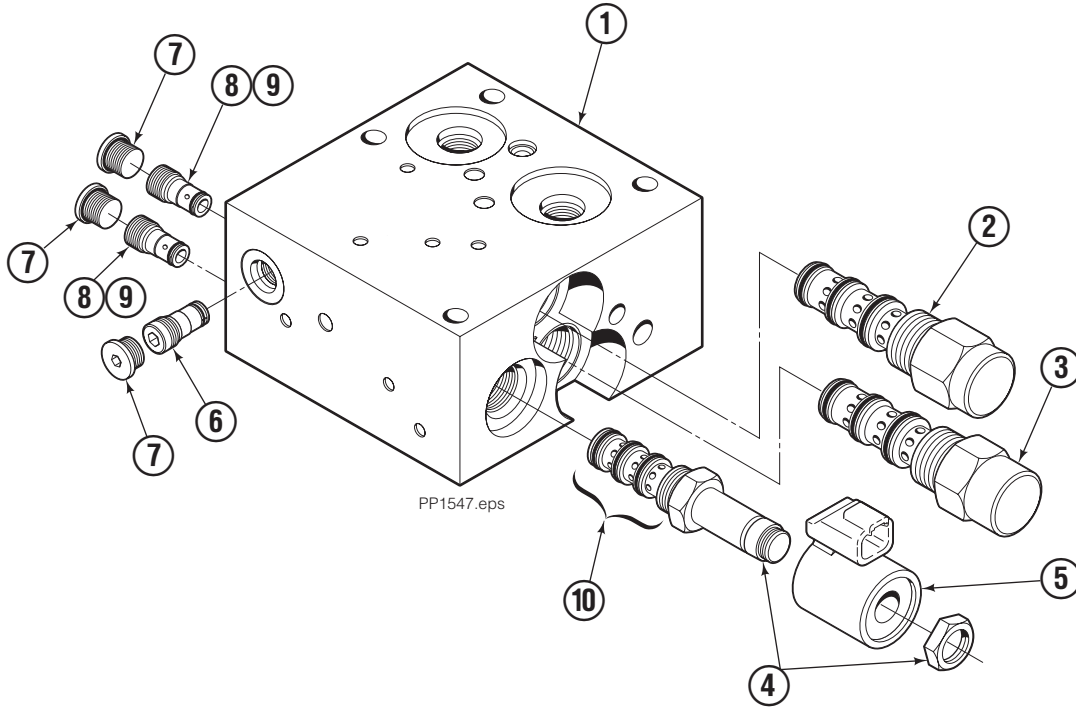

REF	QTY	PART NO.	DESCRIPTION
		6070947	Valve Assembly
1	1	6070946	Valve Body
2	1	6069787	Cartridge
3	1	6069792	Cartridge
4	1	220627	Solenoid Valve Cartridge
5	1	6054451	Solenoid Coil, 10 VDC
6	1	220865	Shuttle Valve
7	3	609234	Plug
8	2	6057940	Check Valve Cartridge
9	2	6025595	Service Kit
10	1	221049	Service Kit

Blank

**Do you have questions you need answered right now?** Call your nearest Cascade Service Department. Visit us online at [www.cascorp.com](http://www.cascorp.com)

### **AMERICAS**

**Cascade Corporation  
Parts Sales**  
2501 Sheridan Ave.  
Springfield, OH 45505  
Tel: 888-CASCADE (227-2233)  
Fax: 888-329-0234

**Cascade Canada Inc.**  
5570 Timberlea Blvd.  
Mississauga, Ontario  
Canada L4W-4M6  
Tel: 905-629-7777  
Fax: 905-629-7785

**Cascade do Brasil**  
Rua João Guerra, 134  
Macuco, Santos - SP  
Brasil 11015-130  
Tel: 55-13-2105-8800  
Fax: 55-13-2105-8899

### **EUROPE-AFRICA**

**Cascade Italia S.R.L.  
European Headquarters**  
Via Dell'Artigianato 1  
37050 Vago di Lavagno (VR)  
Italy  
Tel: 39-045-8989111  
Fax: 39-045-8989160

**Cascade (Africa) Pty. Ltd.**  
PO Box 625, Isando 1600  
60A Steel Road  
Sparton, Kempton Park  
South Africa  
Tel: 27-11-975-9240  
Fax: 27-11-394-1147

### **ASIA-PACIFIC**

**Cascade Japan Ltd.**  
2-23, 2-Chome,  
Kukuchi Nishimachi  
Amagasaki, Hyogo  
Japan, 661-0978  
Tel: 81-6-6420-9771  
Fax: 81-6-6420-9777

**Cascade Korea**  
121B 9L Namdong Ind.  
Complex, 691-8 Gojan-Dong  
Namdong-Ku  
Inchon, Korea  
Tel: +82-32-821-2051  
Fax: +82-32-821-2055

**Cascade-Xiamen**  
No. 668 Yangguang Rd.  
Xinyang Industrial Zone  
Haicang, Xiamen City  
Fujian Province  
P.R. China 361026  
Tel: 86-592-651-2500  
Fax: 86-592-651-2571

**Cascade India Material  
Handling Private Limited**  
No 34, Global Trade Centre  
1/1 Rambaugh Colony  
Lal Bahadur Shastri Road,  
Navi Peth, Pune 411 030  
(Maharashtra) India  
Phone: +91 020 2432 5490  
Fax: +91 020 2433 0881

**Cascade Australia Pty. Ltd.**  
1445 Ipswich Road  
Rocklea, QLD 4107  
Australia  
Tel: 1-800-227-223  
Fax: +61 7 3373-7333

**Cascade New Zealand**  
15 Ra Ora Drive  
East Tamaki, Auckland  
New Zealand  
Tel: +64-9-273-9136  
Fax: +64-9-273-9137

**Sunstream Industries  
Pte. Ltd.**  
18 Tuas South Street 5  
Singapore 637796  
Tel: +65-6795-7555  
Fax: +65-6863-1368

