



Technical Bulletin

E-Series Load Stabilizer Arm and Contact Pad Flex Joint Kits 205980 and 205981

This sheet describes modifications required to install new rubber washers and sleeves to the arm and contact pad flex joint. These new parts allow fine adjustment of contact pad flex. Service kit applications are listed below:

Beverage Units – Service Kit 205980

Bottled Water Units – Service Kit 205981

- 1 Remove the contact pad and bottom plate (if equipped) from the arm. It may be necessary to cut or grind off the capscrews to remove them.

Beverage Arm

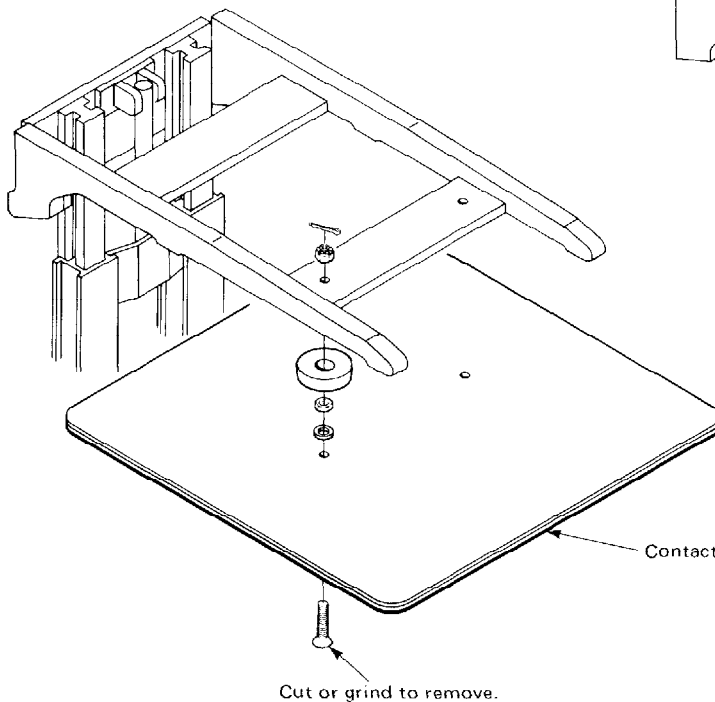

Bottled Water Arm

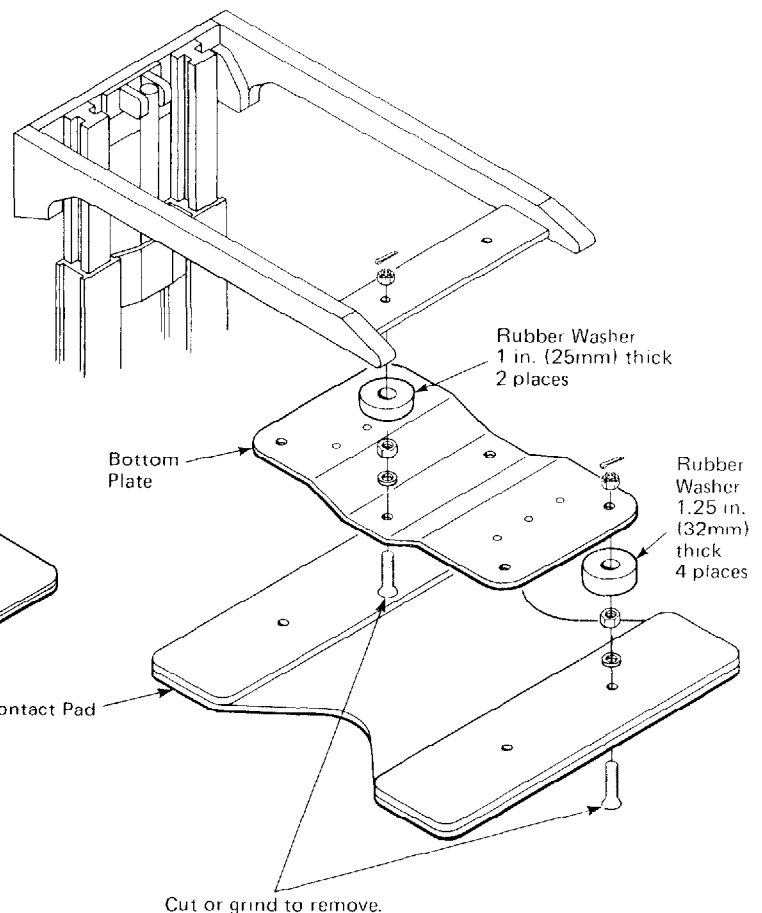

Part No. 205189

cascade®

For Technical Assistance . . .

Call: 1-800-CASCADE or 503-669-6300

OR

Write: Cascade Corporation, PO Box 20187, Portland, OR 97220

To Order Parts . . .

Call: 513-322-1199

OR

Write: Cascade Corporation, 2501 Sheridan Ave., Springfield, OH 45505

- 2 Drill the arm (2 places) and bottom plate holes—if equipped (4 places) to 7/8 in. (22 mm) diameter using cutting oil. Chamfer the top and bottom sides of the arm holes.

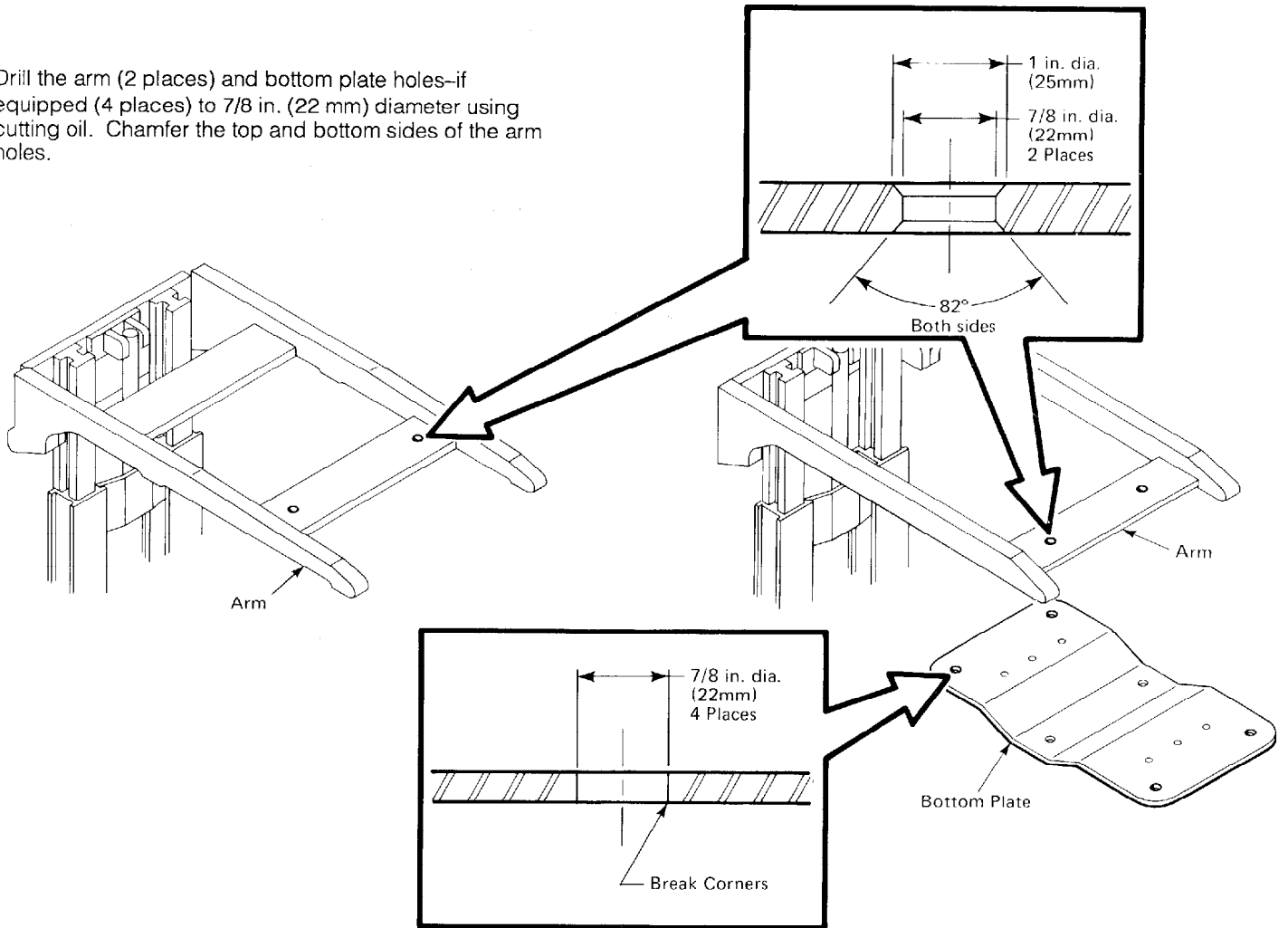

- 3 Reassemble the arm using the new components. Tighten the nut to a torque of 36-40 ft.-lbs. (50-55 Nm).

NOTE: The flex between the arm and contact pad can be adjusted by the number of washers installed inside the rubber washer.

