

I **INSTALLATION INSTRUCTION**

F-Series

90FX Swing Frame

Paper Roll Clamp

Electric Trucks

Manual Number 6028021 R-1

**cascade[®]
corporation**

Cascade is a Registered Trademark of Cascade Corporation

Recommended Hydraulic Supply	i
Truck Requirements	1
Installation	2
Periodic Maintenance	11

This Manual provides instructions for installing the Cascade 90FX-Series Paper Roll Clamp on lift trucks.

Follow the suggested installation procedures for best results. If you have any questions or need more information, contact your nearest Cascade Service Department (see back cover).

Read the **WARNING** Statements placed throughout this Manual to emphasize safety during installation.

IMPORTANT: Field alterations may impair performance or capability and could result in loss of warranty. Consult Cascade for any required modifications.

R ECOMMENDED HYDRAULIC SUPPLY

The FX-Series Swing Frame Paper Roll Clamp requires two (2) hydraulic circuits over the mast to provide three (3) functions CLAMP, ROTATE and SWING on the Attachment. No solenoid adaption is required. Recommended hydraulic supply arrangement is **A and B**, or **C**. Refer to Cascade *Hose and Cable Reel Selection Guide*, Part No. 212199, to select the correct hose reel for the mast and truck. Hose and fitting requirements are:

- No. 8 with .400 in. (10 mm) minimum I.D. for both CLAMP and ROTATE/SWING functions.

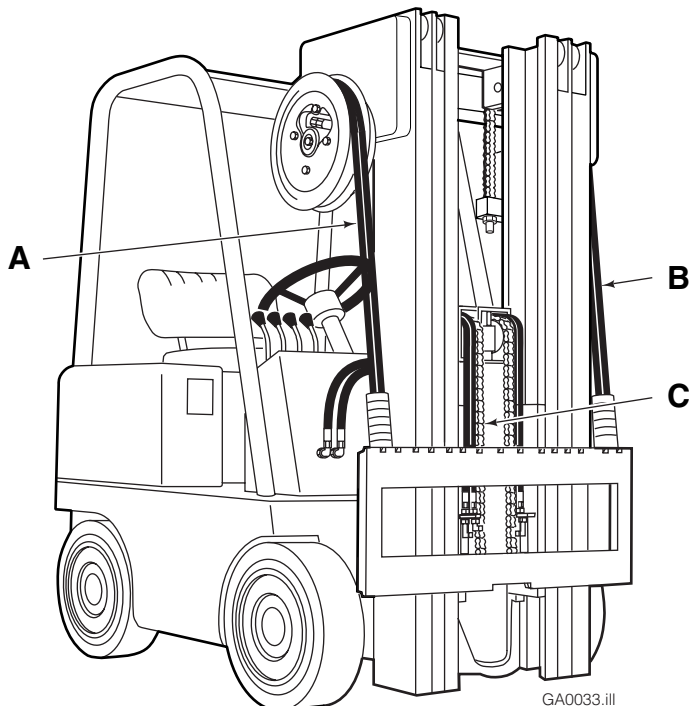

A and B

RH and LH THINLINE™ 2-Port Hose Reel Groups.

OR

C

Mast Double Internal Hose Reeving Group.

OR (optional)

A or B and C

LH or RH THINLINE™ 2-Port Hose Reel Group and Mast Single Internal Hose Reeving Group.

T RUCK REQUIREMENTS

WARNING: Rated capacity of the truck/attachment combination is a responsibility of the original truck manufacturer and may be less than that shown on the attachment nameplate. Consult the truck nameplate.

Truck Relief Setting

2000 psi (140 bar) Recommended
2300 psi (160 bar) Maximum

Truck Flow Volume ^①

	Min. ^②	Recommended	Max. ^③
90FX	12 GPM (45 L/min.)	15 GPM (56 L/min.)	20 GPM (75 L/min.)

① Cascade Roll Clamps are compatible with SAE 10W petroleum base hydraulic fluid meeting Mil. Spec. MIL-0-5606 or MIL-0-2104B. Use of synthetic or aqueous base hydraulic fluid is not recommended. If fire resistant hydraulic fluid is required, special seals must be used. Contact Cascade.

② Flow less than minimum will result in a rotate speed less than 2 RPM.

③ Flow greater than maximum can result in excessive heating, reduced system performance and short hydraulic system life.

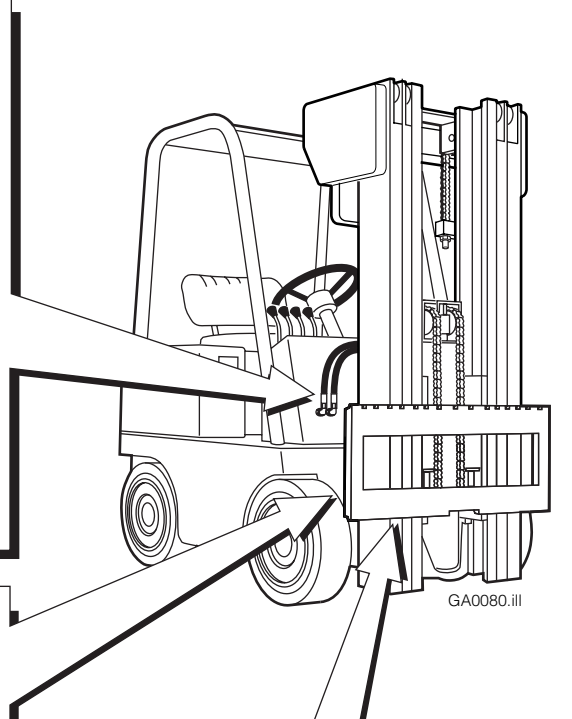

Carriage Mount Dimension (A) ITA (ISO)

	Minimum	Maximum
Class II	14.94 in. (380.0 mm)	15.00 in. (381.0 mm)
Class III	18.68 in. (474.5 mm)	18.74 in. (476.0 mm)
Class IV	23.44 in. (595.5 mm)	23.50 in. (597.0 mm)

GA0028.iii

Carriage
Clean and inspect carriage bars for damage and smoothness. Repair any protruding welds or damaged notches.

Auxiliary Valve Functions

Check for compliance with ITA (ISO) standards:

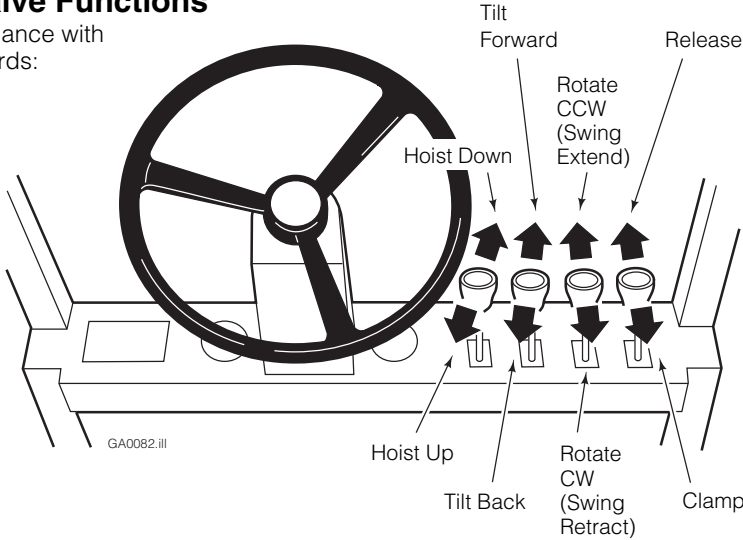

Truck Preparation

NOTE: Prior to installing the 90FX Paper Roll Clamp, install the following components on the truck:

- Solenoid-operated 3N2 control valve in the CLAMP and ROTATE supply lines to the Attachment.
- 'Tee' adapter in the truck tank main return line for return-to-tank from the 3N2 Control Valve.

1 Install 'Tee' adapter

A Determine a suitable location and install the 'tee' adapter in the truck tank main return line.

CAUTION: Do not install into power steering or other tank return lines.

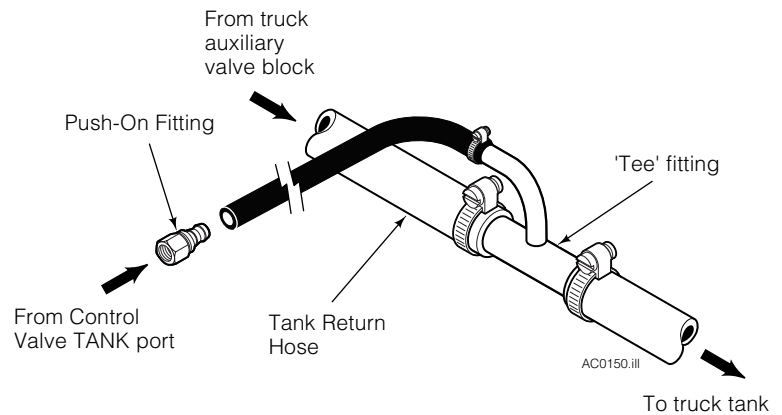

2 Mount 3N2 Control Valve

Determine a suitable mounting location for the solenoid-operated control valve. If mounted on the truck cowl as shown, the valve must not extend outside the width of the cowl or interfere with the truck mast when tilted back.

If the valve is mounted in the engine compartment, make sure it is securely mounted. Use hose clamps or cable ties as necessary.

NOTE: Control valve ports are drilled straight-through allowing 'tee' connections when opposite ports are capped. Straight-through connections are preferred to reduce entrapped air and enable use of straight fittings.

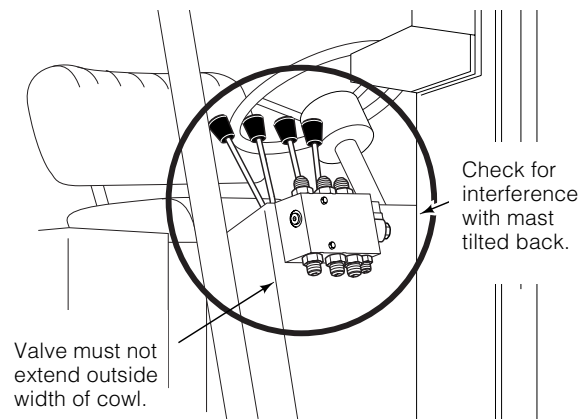

RC1301.iii

3 Install tank return hose

Install a hose from the 3N2 control valve TANK port to the 'tee' adapter installed in Step 1.

4 Install clamp circuit hoses

Measure and assemble hoses (user-supplied) for the clamp circuit. Install hoses using straight fittings wherever possible. Use hose clamps as necessary to secure hoses and prevent chafing.

Install a hose from the truck auxiliary valve port to the control valve CLAMP IN port.

Install a second hose from the CLAMP OUT port to a LH or RH 2-Port hose reel or internal reeving.

Install a third hose from truck auxiliary valve port to the LH 2-Port hose reel or internal reeving.

NOTE: Revolving Connection end block may have either LH or RH porting for the CLAMP and ROTATE/SWING circuits (LH CLAMP and ROTATE circuit shown below).

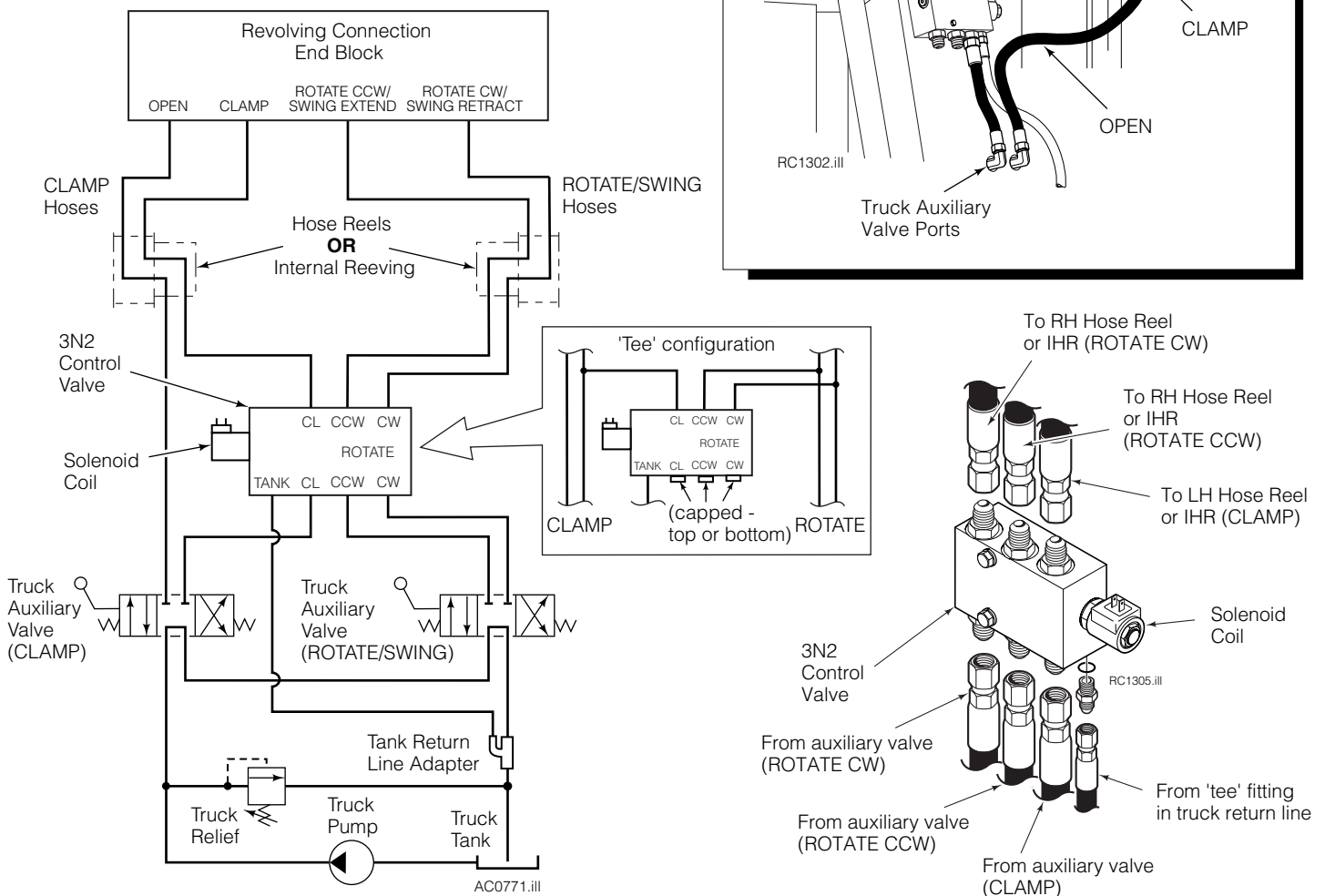
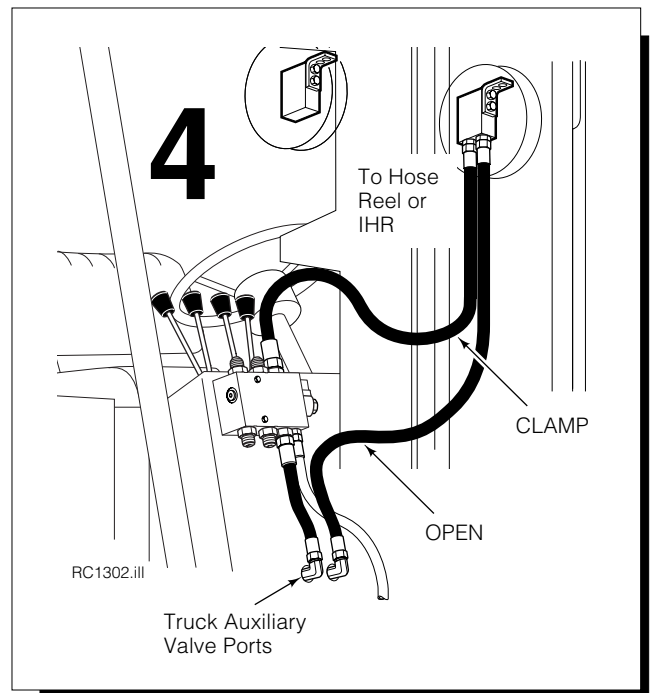
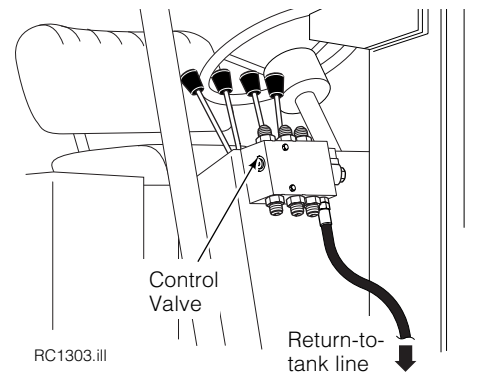

5 Install Rotate/Swing circuit hoses

Measure and assemble hoses (user-supplied) for the rotate/swing circuit. Install hoses using straight fittings wherever possible. Use hose clamps as necessary to secure hoses and prevent chafing.

The first set of rotate/swing function hoses run from truck auxiliary valve ports to the control valve ROTATE IN ports.

The second set of rotate function hoses run from control valve ROTATE OUT ports to a LH or RH 2-Port hose reel or internal reeving.

NOTE: Revolving Connection end block may have either LH or RH porting for the CLAMP and ROTATE/SWING circuits (LH CLAMP circuit shown below).

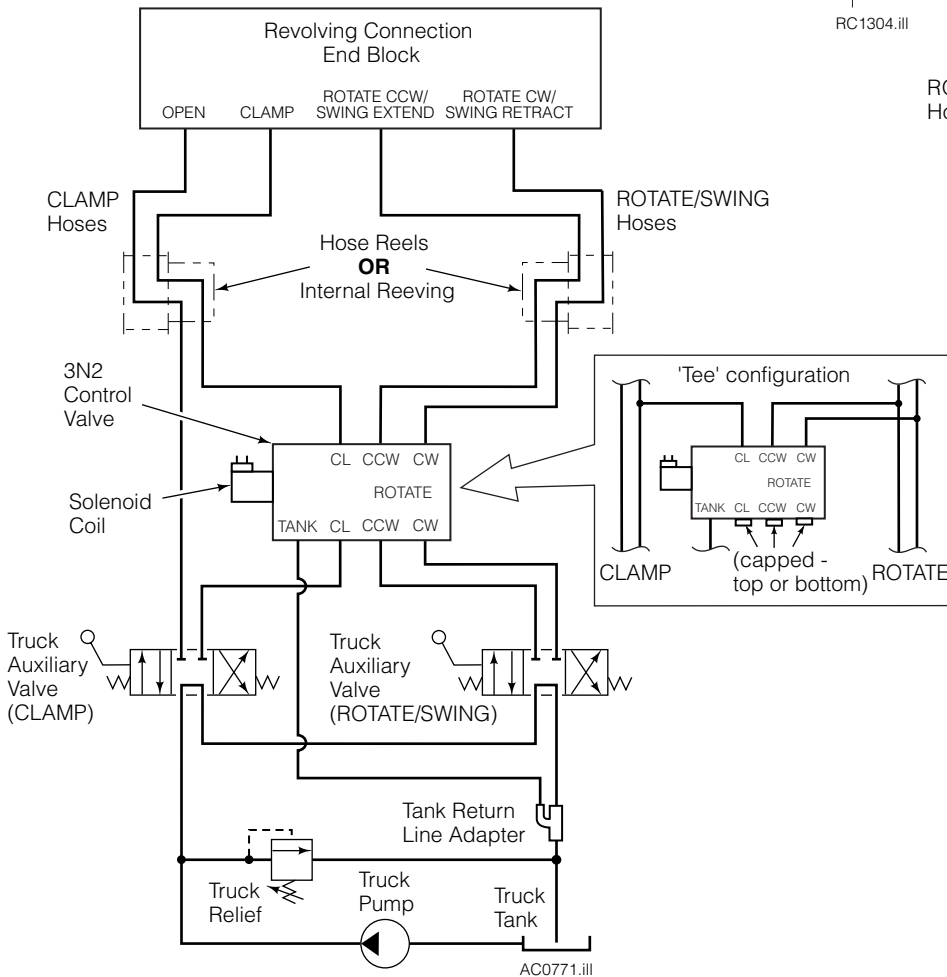
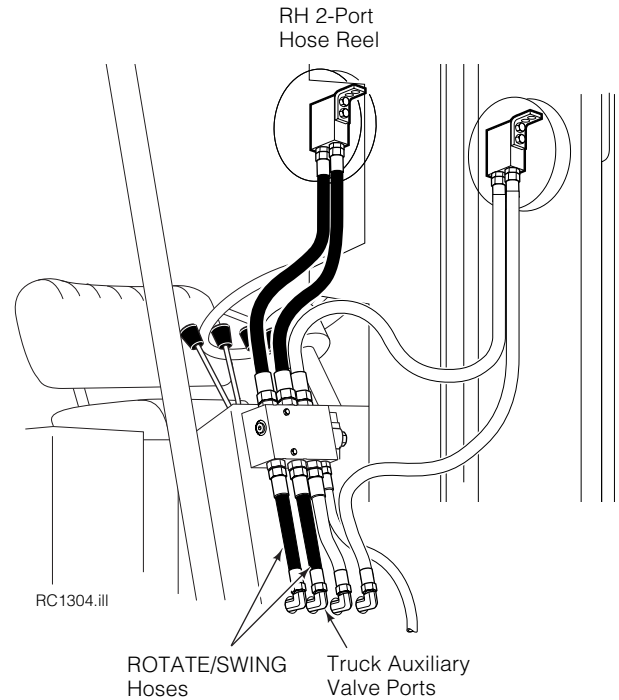

6 Install pushbutton switch for SWING function

- A** Mount the pushbutton switch on the ROTATE function control lever using double-sided foam tape. Apply heat-shrink tubing over control lever and switch. Use cable ties as necessary to secure wiring.
- B With Power Relay** – Connect the wiring harness and cables as shown in **B** below.
- C Direct connection** – Connect the wiring harness and cables as shown in **C** below.

IMPORTANT: Pushbutton should be installed on ROTATE function lever (ITA Standards). When pushbutton is depressed, control lever should activate SWING function.

CAUTION: Consult OEM for proper positive (+) power source connection.

CONTROL LEVER with PUSHBUTTON SWITCH

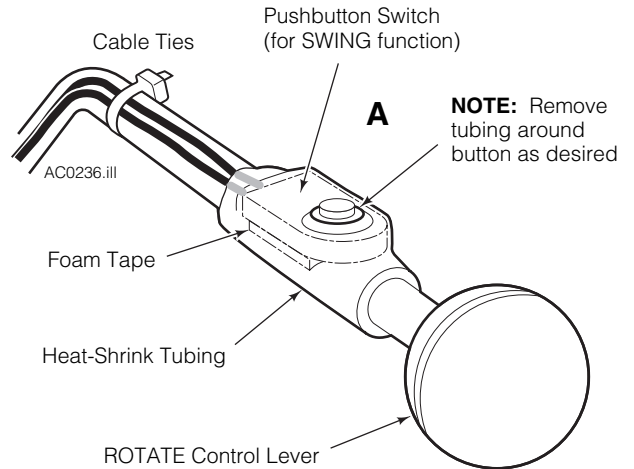

B ELECTRICAL HOOKUP WITH RELAY (recommended)

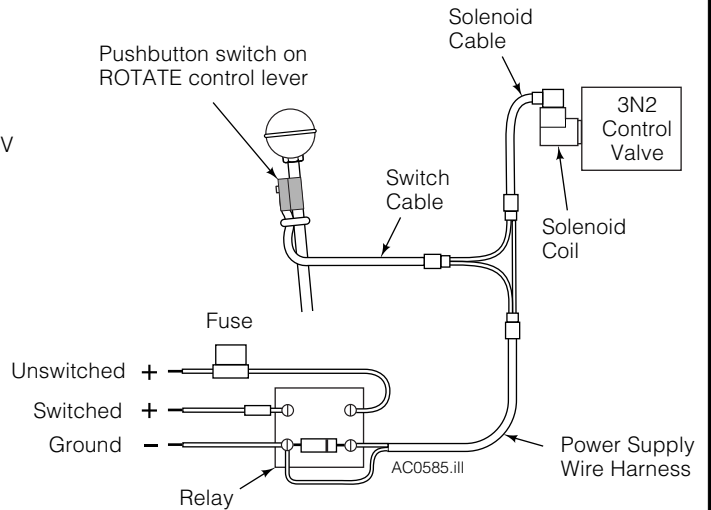
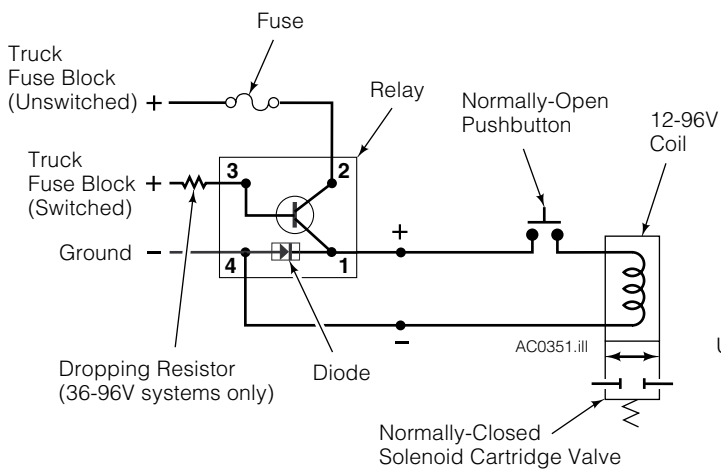

C DIRECT CONNECTION

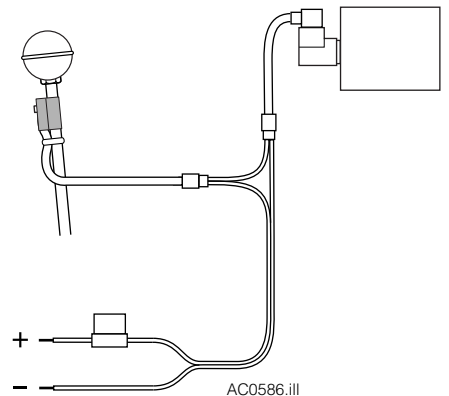
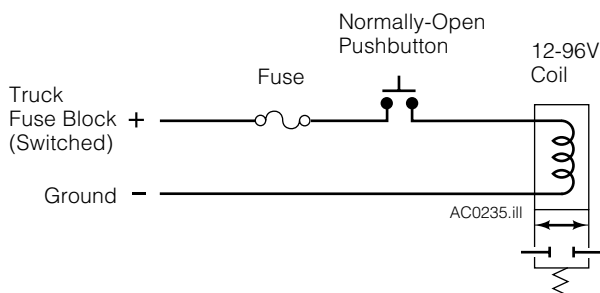

Clamp Installation

1 Attach overhead hoist

- A** Remove banding, set Roll Clamp upright on pallet.
- B** Remove bolt-on lower mounting hooks.



WARNING: Make sure overhead hoist and related components have a rated capacity of at least 3500 lbs. (1600 kg).

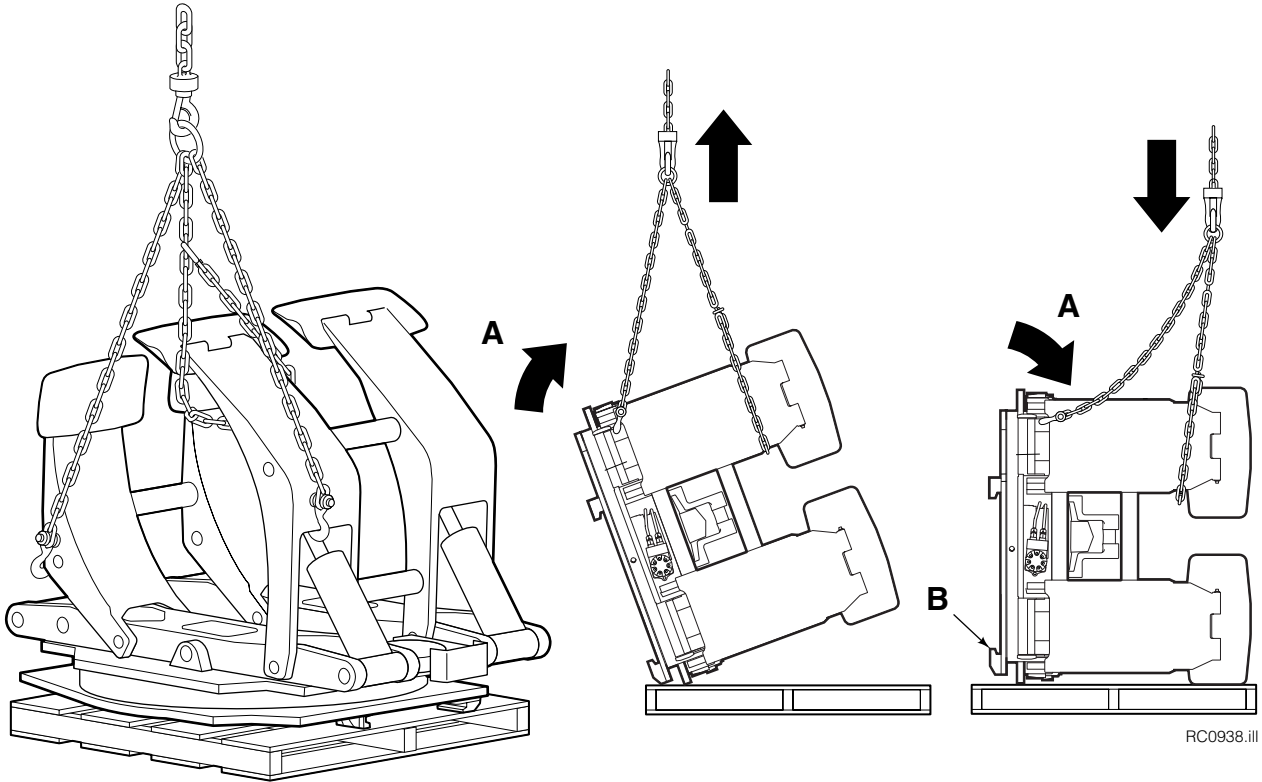

2 Remove lower mounting hooks

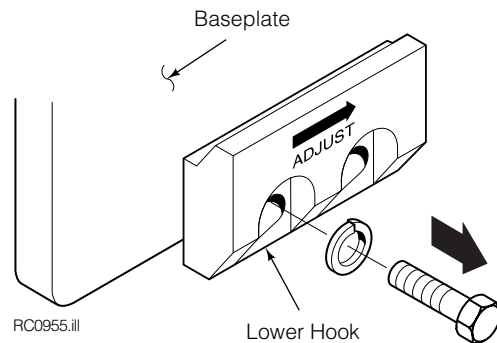

3 Prepare Hoses or Install Hose Kits

- A** Position truck carriage behind roll clamp.
- B** Determine hose lengths required.
- C** Cut hoses to length, install end fittings and connect hoses to truck supply terminals for flushing.

CAUTION: Hoses should be 2300 psi working-pressure rated for all attachment functions. No. 8 hose is recommended for all functions.

NOTE: Revolving Connection end block may have either LH or RH porting for the CLAMP and ROTATE/SWING circuits (LH CLAMP circuits shown in following illustrations).

INSTALLATION USING RH & LH 2-PORT THINLINE™ HOSE REELS:

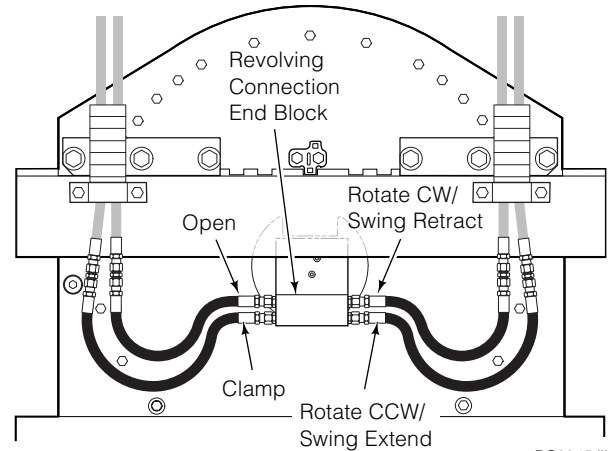

INSTALLATION USING RH 2-PORT THINLINE™ HOSE REEL AND SINGLE INTERNAL HOSE REEVING:

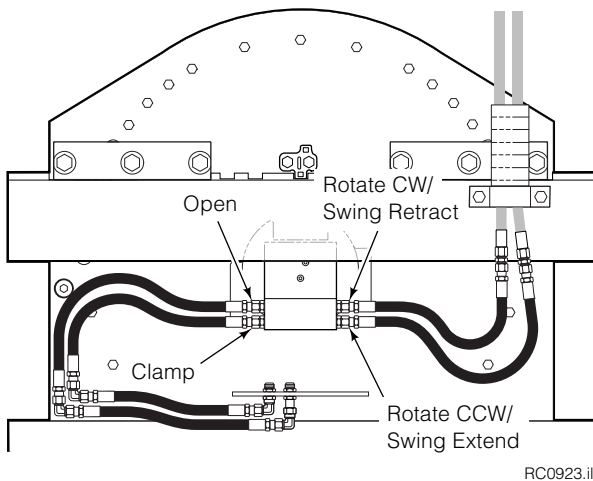

INSTALLATION USING DOUBLE INTERNAL HOSE REEVING:

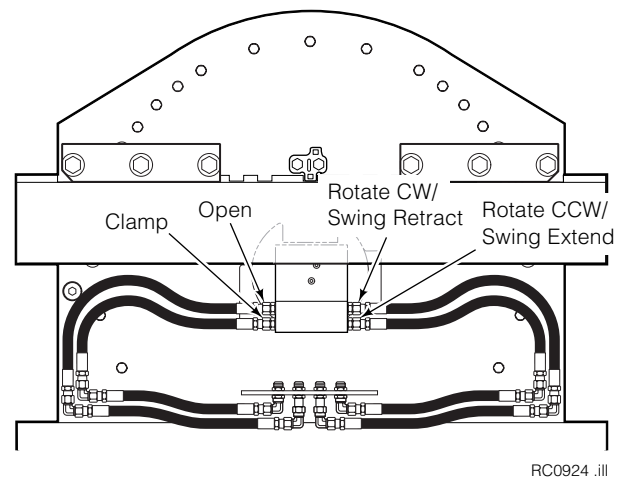

4 Flush hydraulic supply hoses

- A** Connect hoses together using union fittings as shown.
- B** Operate auxiliary valves for 30 sec.
- C** Remove union fittings.
- D IMPORTANT:** Disconnect hoses from supply terminals and connect to roll clamp revolving connection end block fittings as shown in Step 3 above.

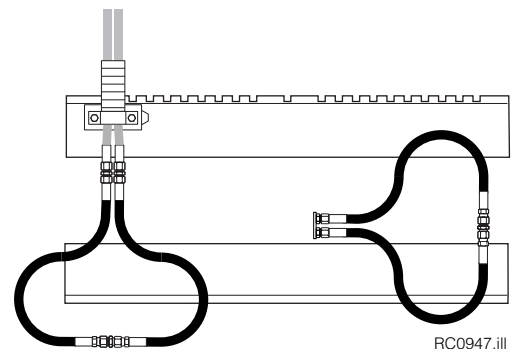

5 Mount clamp on truck carriage

- A** Center truck behind the roll clamp.
- B** Tilt forward and raise carriage into position.
- C** Engage top mounting hooks with carriage. Make sure centering tab engages a notch on the top carriage bar. **NOTE:** Centering tab can be oriented to 4 different positions to center the Clamp (see illustration).
- D** Lift Clamp 2 in. (5 cm) off pallet.

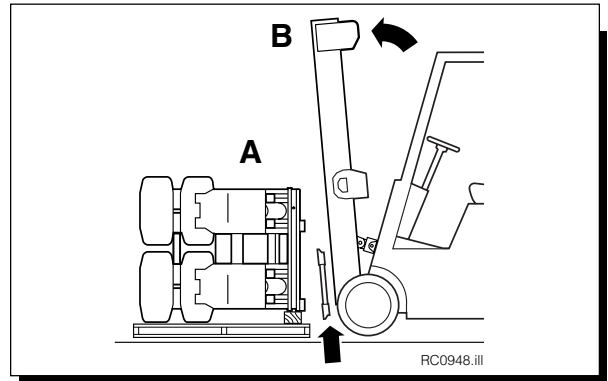

ITA Class III – 0.72–0.78 in. (18–20 mm)
 ITA Class IV – 0.72–0.78 in. (18–20 mm)

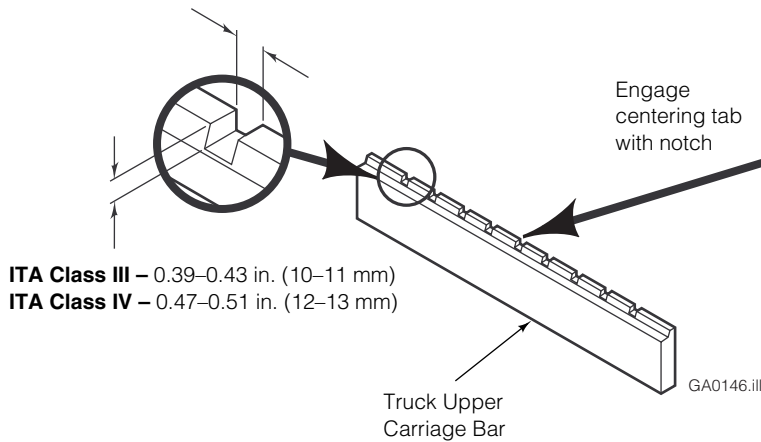

ITA Class III – 0.39–0.43 in. (10–11 mm)
 ITA Class IV – 0.47–0.51 in. (12–13 mm)

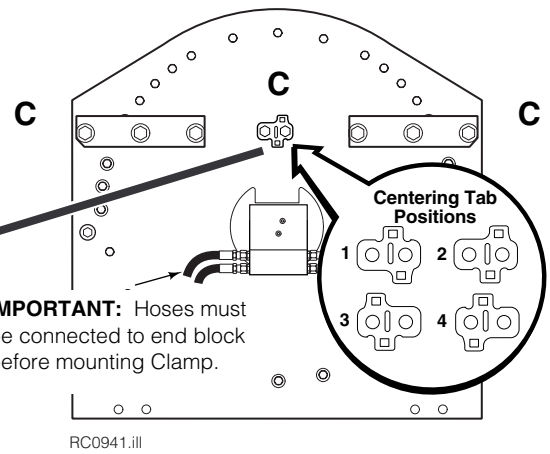

IMPORTANT: Hoses must be connected to end block before mounting Clamp.

Back (Driver's View)

6 Install and engage lower hooks

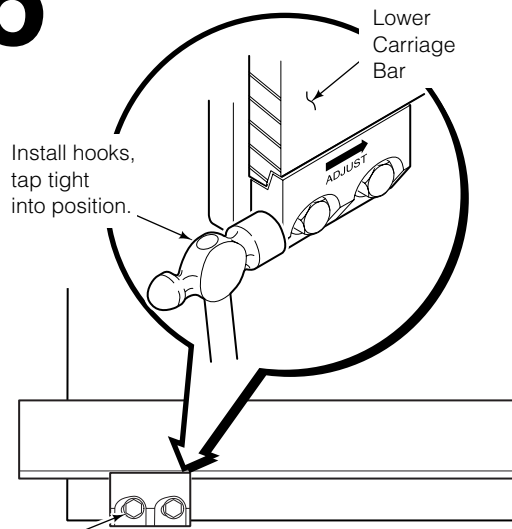

Class IV, 90FX, 100FX – Tighten capscrews to 260 ft.-lbs. (350 Nm)

7 Connect hoses prepared in Step 3 to truck supply terminals.

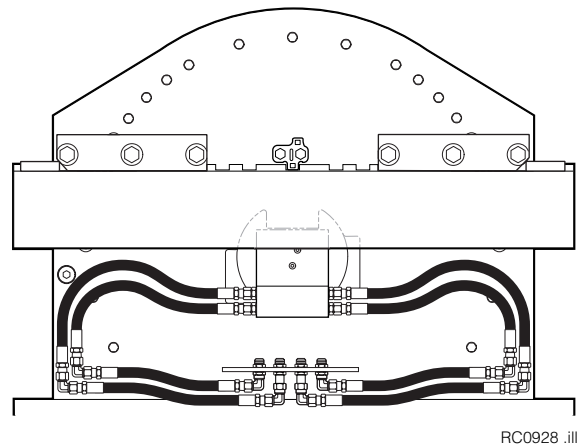
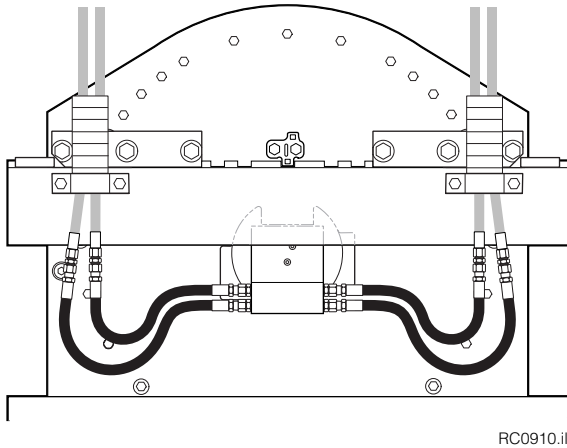

8 Install stop block kit

- Assure that clamp is centered on carriage.
- Preheat each stop block and carriage bar weld area to 325° F (180° C).
- Weld a stop block on each end of top carriage bar as shown. Use AWS E7018 low hydrogen rod and weld a 1/4 in. (6 mm) fillet around each stop block.

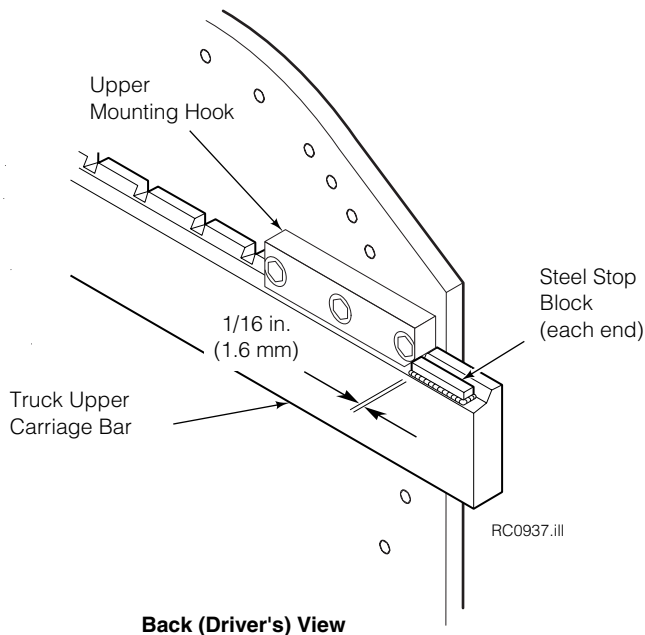

9 Purge air from hydraulic system

IMPORTANT: All functions must be cycled to remove air trapped in the attachment hydraulic system before the unit will function properly. Follow the procedure below:

- Cycle long arm several times.
- Rotate to 45 degrees and cycle short arm several times.
- Rotate clockwise (CW) or counter-clockwise (CCW) several revolutions.
- Cycle swing frame several times while clamp is in vertical roll-handling position.
- Cycle swing frame several times while clamp is in bilge position.

NOTE: If attachment shifts to swing at any time during the above procedure, actuate the CLAMP lever and resume rotating until air is fully purged.

10 Cycle attachment functions



WARNING: Make sure all personnel are clear of the clamp during testing.

IMPORTANT: Make sure hydraulic system is purged of air before checking attachment functions outlined below (see Step 9).

- With no load, cycle all functions several times.
- Check functions for operation in accordance with ITA (ISO) standards.
- Clamp and rotate a maximum load, check for smoothness and normal rotation.
- Check for leaks at fittings, revolving connection and cylinder rod ends.

LONG ARM
(vertical & horizontal positions only)

- C** Release
- D** Clamp

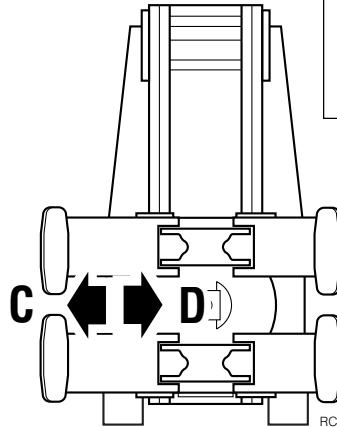

RC1549.iii

SWING
(Bilge handling shown)

- A** (Push button) Extend
- B** (Push button) Retract

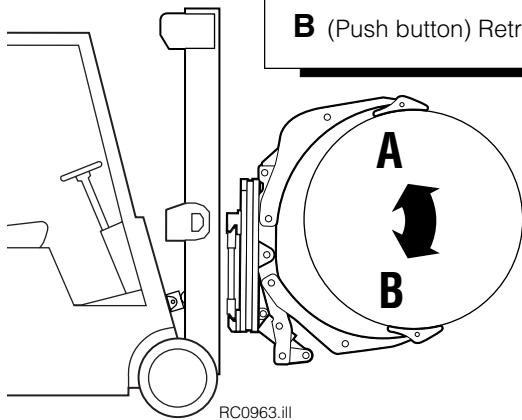

RC0963.iii

ROTATE
(Driver's view)

- A** Counterclockwise (CCW)
- B** Clockwise (CW)

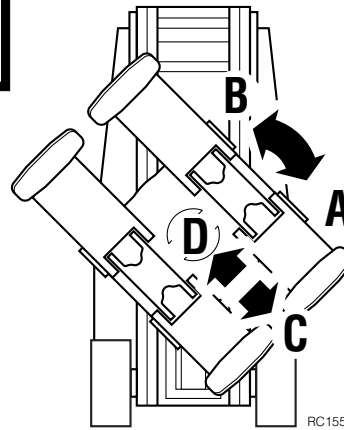

RC1550.iii

SHORT ARM
(45 degree position only)

- C** Open
- D** Close

NOTE: Extension or retraction of swing cylinder swings attachment up or down, left or right, depending on which orientation clamp arms are rotated to.

AUXILIARY VALVE FUNCTIONS

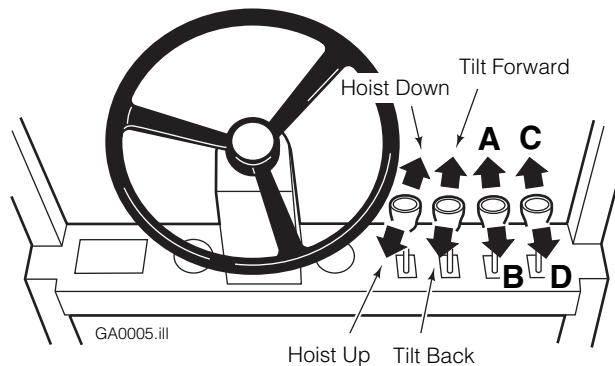

GA0005.iii

100-Hour Maintenance

Every time the lift truck is serviced or every 100 hours of truck operation, whichever comes first, complete the following maintenance procedures:

- Check for loose or missing bolts, worn or damaged hoses and hydraulic leaks.
- Check edges of contact pads for wear or sharp nicks that could damage or tear paper rolls. Grind edges smooth.
- Check contact pad pivot joints for wear and replace or repair if necessary (see Service Manual).
- Check that load holding hydraulic system is functioning properly. Clamp Force Indicators 831887, 830141 and 832442 are available for this test.
- Check decals and nameplate for legibility.

500-Hour Maintenance

After each 500 hours of truck operation, in addition to the 100-hour maintenance, perform the following procedures:

- Tighten baseplate-to-bearing assembly capscrews to 75 ft.-lbs. (95 Nm).
- Tighten faceplate-to-bearing assembly capscrews to 75 ft.-lbs. (95 Nm). **NOTE:** Access capscrews through plug in baseplate (see illustration).
- Lubricate rotator bearing assembly with wheel bearing grease. Rotate clamp in 90-degree increments and grease in each position.
- Tighten all mounting hook capscrews to 260 ft.-lbs. (350 Nm).
- Check rotator drive gearcase lubricant level. Rotate clamp so rotator drive is upright and remove small hex socket plug from top of front cover. Lubricant should run out of hole. If necessary, rotate Clamp 90 degrees and fill with Cascade Rotator Drive Lubricant, Part No. 656300, or SAE 90 wt. gear lube (AGMA 'mild' 6 EP Gear Oil). **CAUTION:** Replace check plug using Loctite 271.
- Inspect all arm and cylinder pivot bushings for wear and replace if necessary (see Service Manual 674512).
- Inspect all load-bearing structural welds on arms, swing frame pivots, arm pivots and cylinder pivot areas for visual cracks. Replace components as required.

2000-Hour Maintenance

After each 2000 hours of truck operation, in addition to the 100 and 500-hour maintenance, perform the following procedures:

- Inspect all arm and cylinder pivot pins for wear and replace if necessary (see Service Manual 6028021).



WARNING: After completing any service procedure, always test the Clamp through five complete cycles. First test empty, then test with a load to make sure the Clamp operates correctly before returning it to the job.

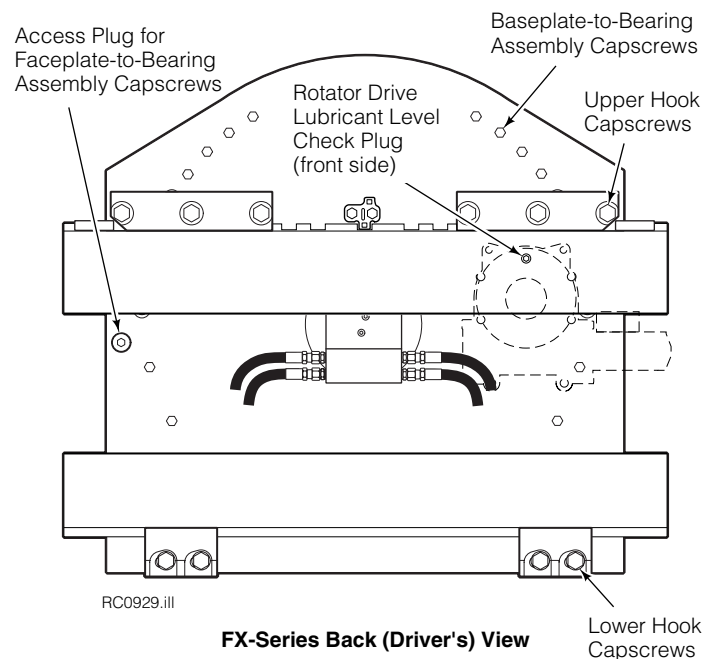
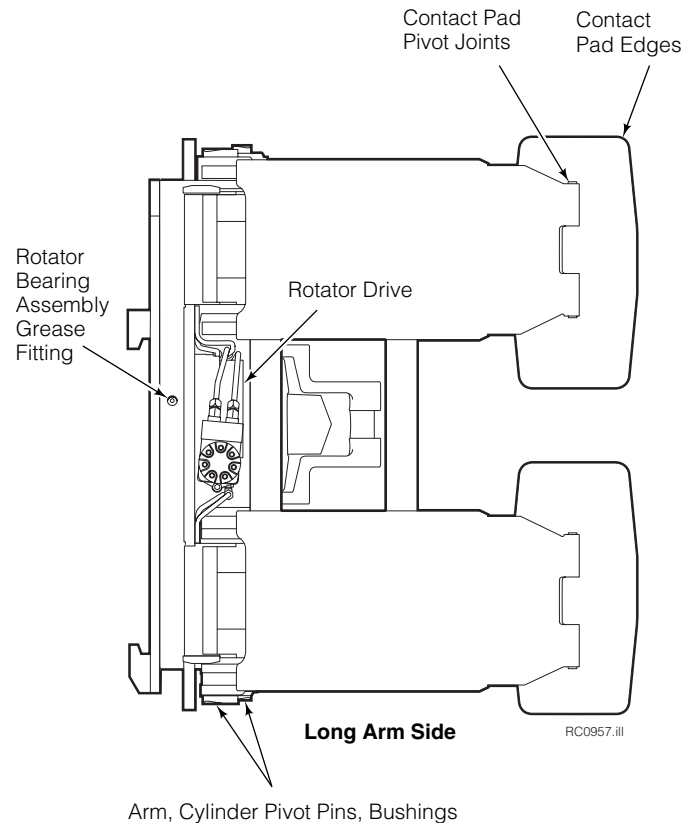

Do you have questions you need answered right now? Call your nearest Cascade Service Department. Visit us online at www.cascorp.com

**Cascade Corporation
U.S. Headquarters**
2201 NE 201st
Fairview, OR 97024-9718
Tel: 800-CASCADE (227-2233)
FAX: 888-329-8207

Cascade Canada Inc.
5570 Timberlea Blvd.
Mississauga, Ontario
Canada L4W-4M6
Tel: 905-629-7777
FAX: 905-629-7785

Cascade GmbH
Dahlener Strasse 570
41239 Mönchengladbach
Germany
Tel: 02166-68230
FAX: 02166-682323

Cascade Finland
A. Petreliuksenkatu 3
01370 Vantaa
Finland
Tel: 09-8361925
FAX: 09-8361935

**Cascade N.V.
Benelux Sales and Service**
Damsluisweg 56
PO Box 3009
1300 El Almere
The Netherlands
Tel: 036-5492950
FAX: 036-5492974

Cascade (UK) Ltd.
Unit 5, Eden Close
Hellaby Lane Ind. Estate
Heellaby,
Rotherham S66 8RW
England
Tel: 01709-704500
FAX: 01709-704501

**Sales Scotland
Macade Systems Ltd.**
18 Melford Road
Righead Ind. Estate
Bellshill ML4 3LR
Scotland
Tel: 01698-845777
FAX: 01698-845888

Cascade (Africa) Pty. Ltd.
PO Box 625, Isando 1600
60A Steel Road
Sparton, Kempton Park
South Africa
Tel: 975-9240
FAX: 394-1147

Cascade Scandinavia AB
Hammarvägen 10
PO Box 124
S-56723 Vaggeryd
Sweden
Tel: 039-336950
FAX: 039-336959

**Cascade France
S.A.R.L. MHP**
1D Rue De Charaintru
BP 18,
91360 Epinay-Sur-Orge
France
Tel: 01-6454-7500
FAX: 01-6454-7501

Cascade Hispania S.A.
Carrer 5, Sector C
Zona Franca Duanera
Poligono de la Zona Franca
08040 Barcelona
Spain
Tel: 93-264-07-30
FAX: 93-264-07-31

Sales Italy
Via Ponzano 11
50047 Prato
Italy
Tel: 0574-571726
FAX: 0574-571726
Mobile Phone: 0337-673029

**Sales Portugal FAG
Santos Lda**
Rua do Mercado
Lte 6, Loja 2-Tires
2785-630
S. Domingos De Rana
Portugal
Tel: 214-448-083
FAX: 214-458-098

**Sales Switzerland
Fahrzeugbedarf**
8810, Horgen
Switzerland
Tel: 01-7279797
FAX: 01-7279798

Sales Poland
Targowa 35/61
03-728 Warszawa
Tel: 022-619 00 49
FAX: 022-619 00 49
Mobile Phone: 0501-27 29 55

Sales Russia
EMCG Material Handling
Equipment
Moscow
Tel: 095-795-2400
FAX: 095-795-2475
Email: emcg@dol.ru

Cascade Japan Ltd.
5-5-41,
Torikai Kami
Settsu, Osaka
Japan, 566
Tel: 81-726-53-3490
FAX: 81-726-53-3497

Cascade Korea
108B Namdong Ind. Complex
658-3 Gojan-Dong
Namdong-Gu
Inchon, 405-310 Korea
Tel: 82-32-821-2051
FAX: 82-32-821-2055

Cascade Australia
1445 Ipswich Road
Rocklea, QLD 4106
Australia
Tel: 1-800227-223
FAX: (07) 3373-7333

Cascade New Zealand
15 Ra Ora Drive
East Tamaki, Auckland
New Zealand
Tel: 9-273-9136
FAX: 9-273-9137

Cascade-Xiamen
No. 668 Yangguang Rd.
Xinyang Industrial Zone
Haicang, Xiamen City
Fujian Province
P.R. China 361026
Tel: 86-592-651-2500
FAX: 86-592-651-2571

**Cascade (Singapore)
Trading Co.**
Four Seasons Park
Autumn Block - Apt. 1802
12 Cuscaden Walk
Singapore
Tel: 65-834-1935
FAX: 65-834-1936

