



Installation Instructions

Basic Clamp for Bolt-on Arms Models: C2B, C3B, C4B, C6B, and C7B

Field alterations may impair performance or capability and could result in loss of warranty. Consult Cascade for technical assistance and approval for any required modifications.



WARNING

Rated capacity of the truck/attachment combination is a responsibility of the original truck manufacturer and may be less than shown on the attachment nameplate. Consult the truck nameplate.

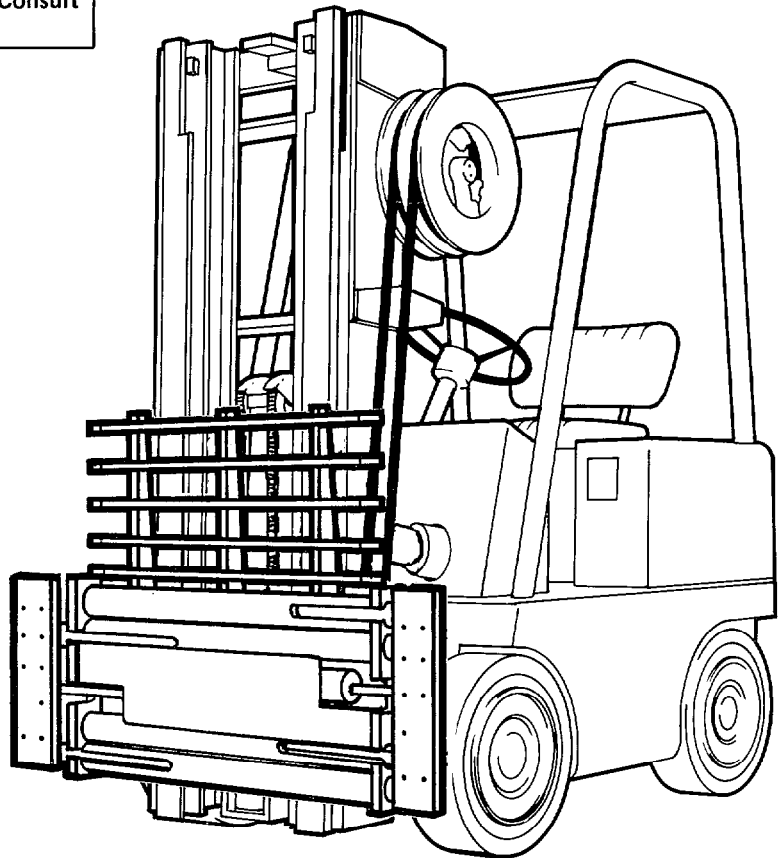

cascade[®]
corporation

P.O. Box 20187 • Portland, Oregon 97220 • (503)666-1511

© Cascade Corporation 1978

A. Truck Requirements

- Recommended hose and fitting size:
 - C2B: No. 6 with minimum fitting orifices of .297 inch (9/32 inch).
 - Remaining Basic Clamps: No. 8 with minimum fitting orifices of .375 inch (13/32 inch).
- Truck system should provide the minimum-maximum rate of flow of 5–15 GPM.
- Truck relief valve setting: 2000 psi maximum.
- Truck carriage must conform to the Industrial Truck Association (ITA) dimensional standards as shown in the following chart:

	Mounting	Dimension A	
		Min.	Max.
	Class II	14.94	15.00
	Class III	18.68	18.74
	Class IV	23.44	23.50

- Make sure the truck carriage is clean and the notches are undamaged.

B. Prior to Installation

1. Install the hydraulic lines to the **junction block** using the correct Cascade Attachment Installation Kit (C-658372 for C2B Basic Clamp; C-658373 for all other Basic Clamps) OR use hoses and fittings as shown in Figures 1 and 2.
Be careful not to pinch, twist, or otherwise damage the hoses. Do not route the hoses where moving parts can damage them. Connect the hoses to the junction block only.

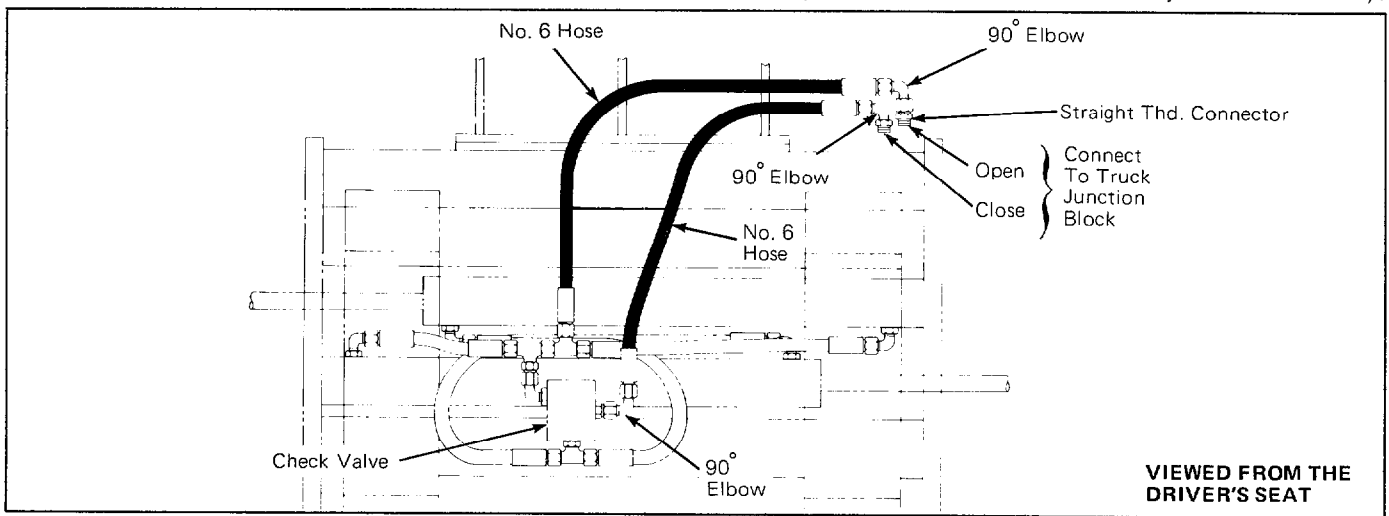

Figure 1. Plumbing Diagram for C2B Basic Clamp (Installation Kit C-658372)

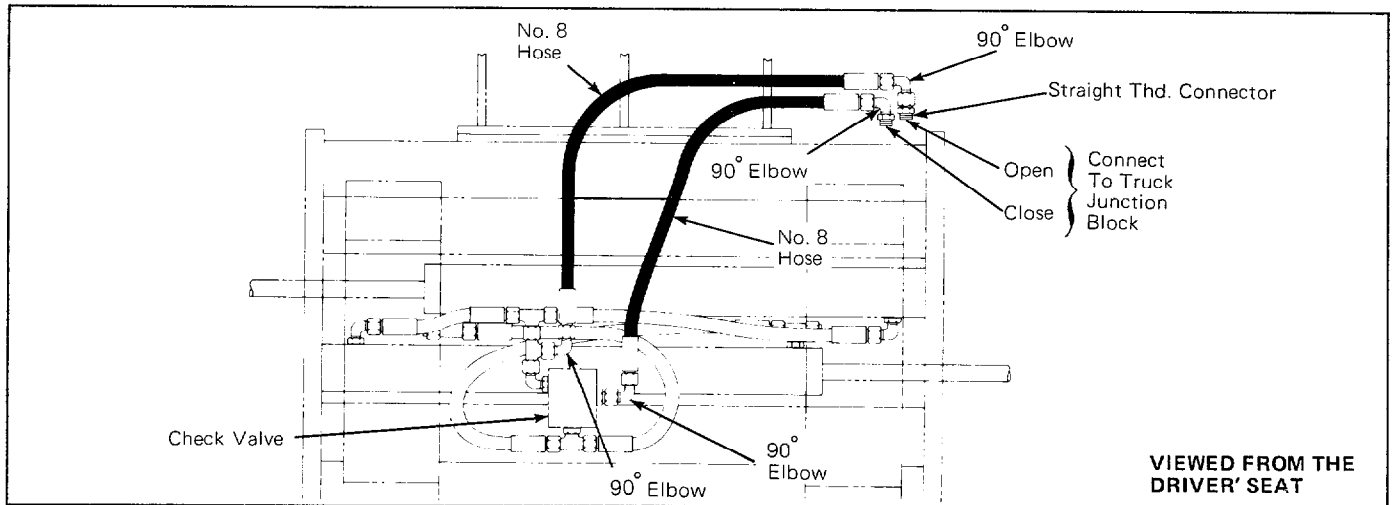

Figure 2. Plumbing Diagram for C3B, C4B, C6B, and C7B Basic Clamps (Installation Kit C-658373)

B. Prior to Installation

(Continued)

IMPORTANT		
In order to conform to the industry standard practice, the hoses should be connected to the truck auxiliary valves as indicated by the following chart.		
Function	Attachment Movement	Motion of the operator's hand
Clamp	Clamp (close)	Rearward or up
	Release (open)	Forward or down

2. Flush the hoses according to the following procedures to prevent damage to the check valve and the cylinders.
 - a. Connect the open and close hoses together using a nipple as shown in Figure 3.

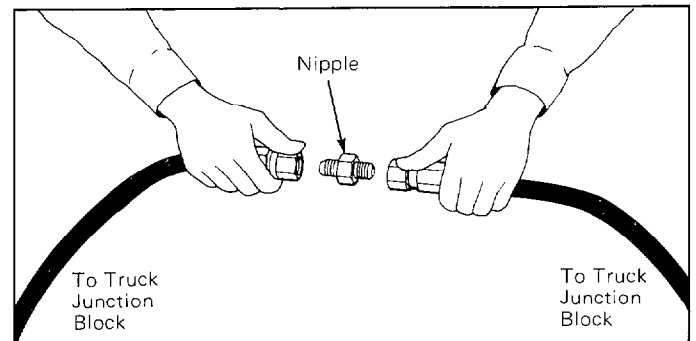

Figure 3. Connect the Two Hoses Together Using a Nipple

- b. Start the truck and actuate the clamp lever about 30 seconds in both directions. This causes a flow through the hoses and will carry debris left in the hoses to the truck hydraulic tank and filter.

C. Installation

WARNING

Make sure your overhead crane has a rated capacity of at least 2500 lbs.

1. If the attachment was shipped with the arms installed, use a hoist chain to set the clamp vertical. If the arms have not been mounted then install eyebolts and attach a hoist chain to each eyebolt. See Figure 4.

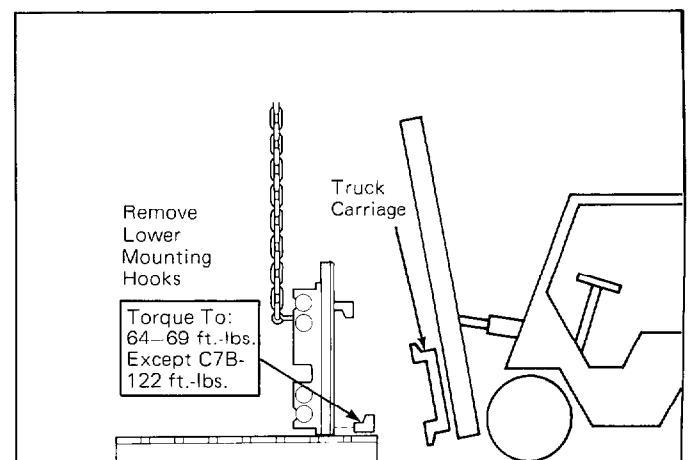

Figure 4. Position for Installation

2. Remove the lower mounting hooks.
3. Position the truck close enough so that the clamp hoses on the junction block can be connected to the check valve on the clamp. See Figure 4.
4. Connect the hoses to the check valve. See Figure 1 or 2.

C. Installation

(Continued)

5. Raise the truck carriage into position aligning the centering block on the clamp with the center notch on the carriage.
6. Install the lower mounting hooks and lube torque the cap-screws to 64–69 ft.-lbs. (C7B, torque to 122 ft.-lbs.).
7. Install the arms. Use the torque values below for the clamp you have.

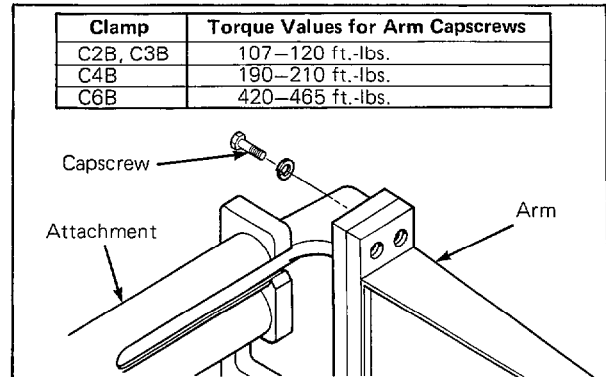

D. Prior to Operation

1. Check the cylinder anchor nuts for proper staking as shown below.

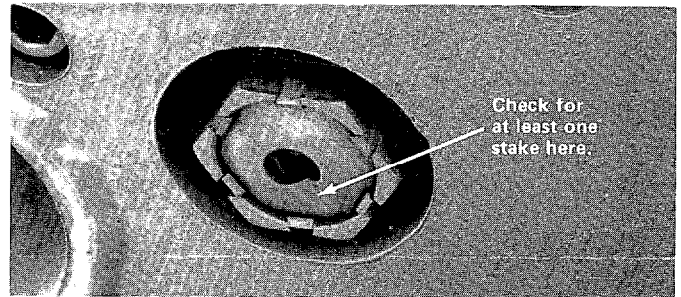

2. Before picking up a load, operate the clamp through a full cycle to force any air from the system to the hydraulic tank.
3. Operate the clamp after picking up a maximum load. If the clamp does not function correctly (clamp opens and closes slowly) then recheck the plumbing. If the clamp drops the load, contact Cascade's Service Department at 800-547-5266 (toll-free), or in Oregon, call 666-1511.



WARNING

Make sure there are no people in the vicinity of the clamp when picking up a load.