



Installation Instructions

Mark 55 Push/Pull Platen Tip Repair Service

This sheet describes platen tip repair procedures for Cascade Mark 55 Push/Pull Attachments. Replacement tips are included for complete set of platens.



WARNING: Cascade Corporation recommends that a qualified or certified welder experienced in this type of repair be used for best quality.

Damaged Tip Removal

- 1 Determine the amount of platen tip to remove as follows: Position the new tip section over the damaged tip, and establish the correct overall faceplate-to-platen tip length. Scribe a grind line as shown.
NOTE: If unsure of the correct platen length, contact Cascade with the Attachment Serial number.
- 2 Remove the platens from the Push-Pull (Refer to Service Manual 686455, Section 5.7 for E-Series.)
- 3 At a suitable distance from the grind line, remove the damaged tip by sawing, oxy-fuel torch, or arc gouging. If torch or arc process is used, allow enough distance from the grind line so the heat-affected zone can be removed to unaffected base metal.

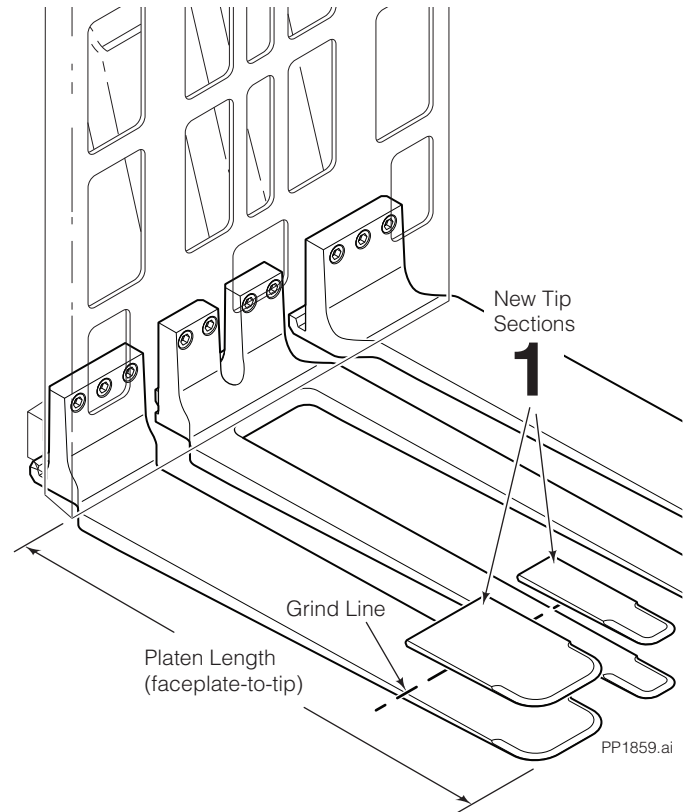

Weld Prep

- 4 Grind the platen and new tip section as shown. Remove all paint, carbon particles or other contaminants from around the repair area prior to welding.

NOTE: This information should not be interpreted as the basis for warranty claims unless so designated.

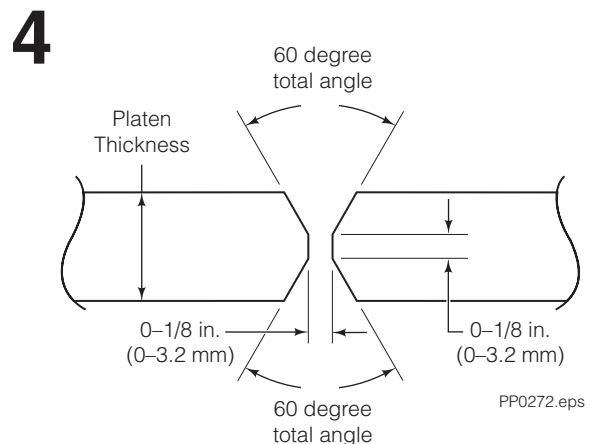

Part Number 6812419

cascade[®]
corporation

For Technical Support . . .

Call: 1-800-227-2233 Fax: 1-888-329-8207
Internet: www.cascorp.com
Write: Cascade Corporation, PO Box 20187, Portland, OR 97294

To Order Parts . . .

Call: 1-888-227-2233 Fax: 1-888-329-0234
Internet: www.cascorp.com
Write: Cascade Corporation, 2501 Sheridan Ave., Springfield, OH 45505

Weld Procedure

5 Align the new replacement tip section with the platen. Clamp both parts securely to a welding table, or similar strongback device. Do all welding in the flat (1F) position using the following weld process:

- **WELD METHOD A (recommended)** – FCAW (Flux-Cored Arc Welding). Attach ground wire to platen. Weld using AWS E110T5-K3 1/16 in. (1.6 mm) or 5/64 in. (2 mm) diameter wire with 100% CO² shielding gas at 35-50 CFH. Set welding amps per manufacturer's recommendations with polarity D.C.R.P.
- **WELD METHOD B (optional)** – SMAW (Shielded Metal Arc Welding). Attach ground wire to platen. Weld using E-11018-M low hydrogen 1/8 in. (3.2 mm) or 5/32 in. (4 mm) diameter electrodes. Set welding amps per manufacturer's recommendations with polarity D.C.R.P. **Do not use electrodes exposed to moisture without first re-drying them at 200° F (75° C) for 2 hours.**

6 Preheat both parts to 70° F (21° C) minimum, and tack-weld the new tip to the platen. Add runoff tabs as shown to eliminate starts and stops on parent metal. Clean tack welds and inspect for cracks.

7 Oven preheat platen to 150°–250° F (66°–121° C). Do not exceed 450° F (232° C). Monitor and maintain preheat and interpass temperatures at locations shown using suitable temperature-indicating devices.

CAUTION: If localized preheat technique is used, preheat must extend fully through base metal thickness, and to a distance of 3 in. (7.5 cm.) on each side of the weld.

8 Rotate platen opposite tack weld side. Clamp and deposit root pass using a stringer bead technique. Do not exceed a bead width of 5/16 in. (8 mm). Start and stop all welds on runoff tabs.

9 Rotate platen to opposite side. Backgrind previous root pass to remove all slag. Clamp and deposit second stringer root pass, assuring 100% full penetration weld.

10 Clean root pass and inspect for cracks. Continue rotating, clamping and depositing stringer passes until joint is entirely filled. Maintain interpass temperature for each pass. Visually inspect each pass.

11 Slow-cool platen to ambient (room) temperature using an insulating blanket.

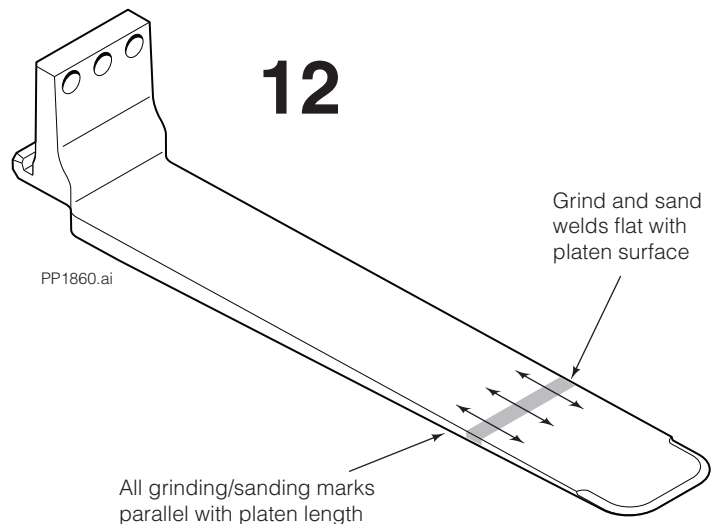
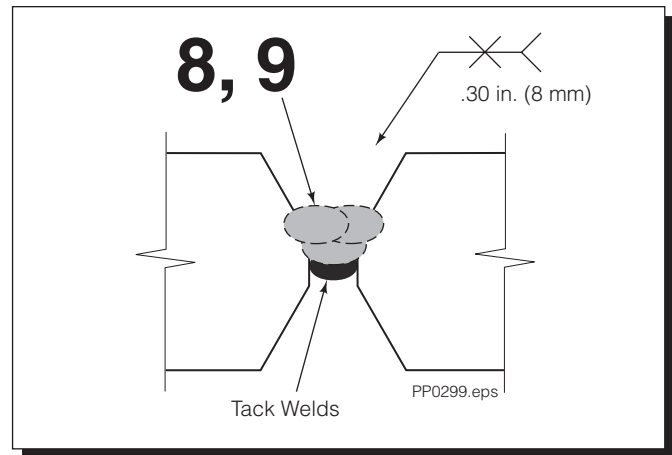
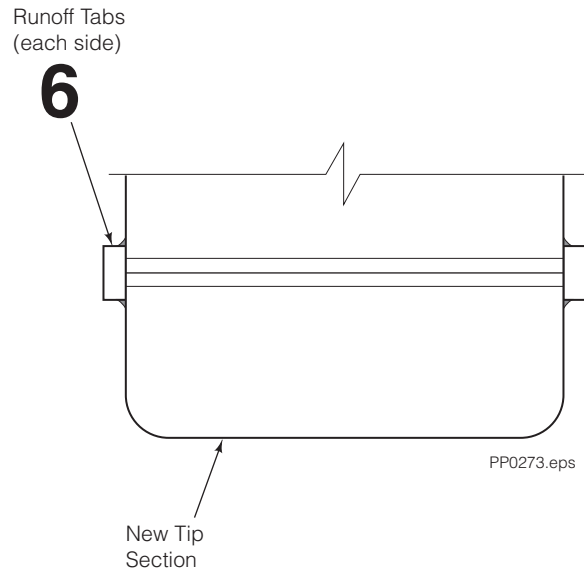

Finishing and Inspection

12 Remove runoff tabs by sawing or grinding and grind all welds flat with platen surface. Finish-sand to a minimum surface roughness of 250. Make all grinding and sanding marks parallel with the platen length.

13 Nondestructive test (NDT) weld area for defects. No undercutting, voids or other defects allowed. Reinstall the platens on the Attachment and check for proper tip alignment (see Service Manual).