

Technical Bulletin

Upper Mounting Hook and Baseplate Capscrew Torque for 55E Single-Double Pallet Handlers

This Bulletin describes procedures to tighten the attachment baseplate and upper hook capscrews. Some units may have shipped from the factory with capscrews tightened to less than the recommended torque value. Removal of the attachment from the truck carriage is necessary.

- 1 Position the outer forks approximately at the width of the frame.



WARNING: Before removing hoses, relieve pressure in the hydraulic system. Turn the truck off, then actuate the truck control valve several times in both directions.

- 2 Disconnect the supply hoses from the valve and sideshift cylinder fittings. Tag hoses for reassembly.
- 3 Remove the lower mounting hooks.
 - Quick Disconnect Hooks** - Remove the pins to lower the hooks.
 - Bolt-On Hooks** - Remove the capscrews fastening the hooks to the baseplate.
- 4 Position the attachment over a pallet. Lower the attachment onto the pallet. Tilt the truck carriage forward and back away.

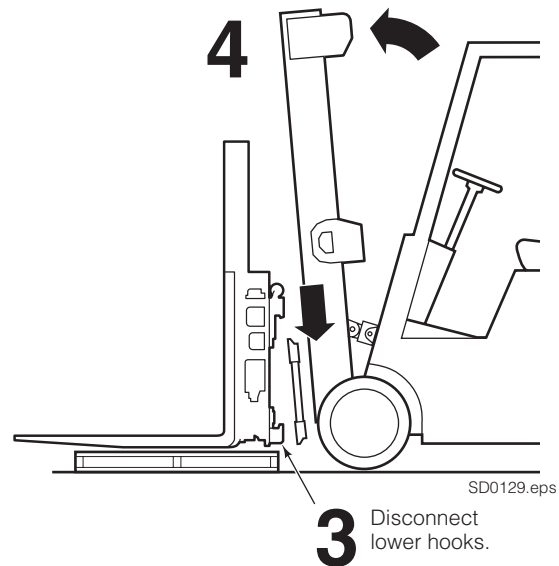
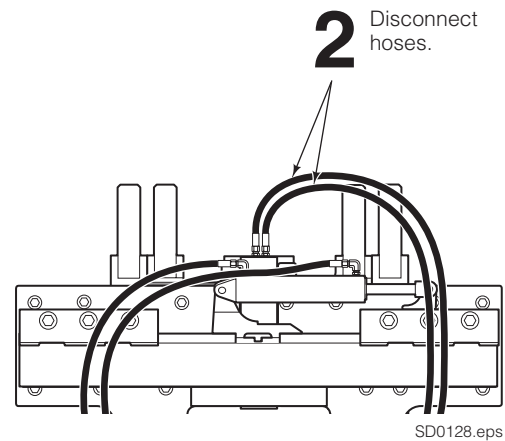

NOTE: This information should not be interpreted as the basis for warranty claims unless so designated.

cascade[®]
corporation

For Technical Support . . .

Call: 1-800-227-2233 Fax: 1-888-329-8207
 Internet: www.cascorp.com
 Write: Cascade Corporation, PO Box 20187, Portland, OR 97294

To Order Parts . . .

Call: 1-888-227-2233 Fax: 1-888-329-0234
 Internet: www.cascorp.com
 Write: Cascade Corporation, 2501 Sheridan Ave., Springfield, OH 45505

5 Tighten the baseplate capscrews to a torque of 74 ft.-lbs. (100 Nm).

6 Tighten the upper hook capscrews to a torque of 125 ft.-lbs. (170 Nm).

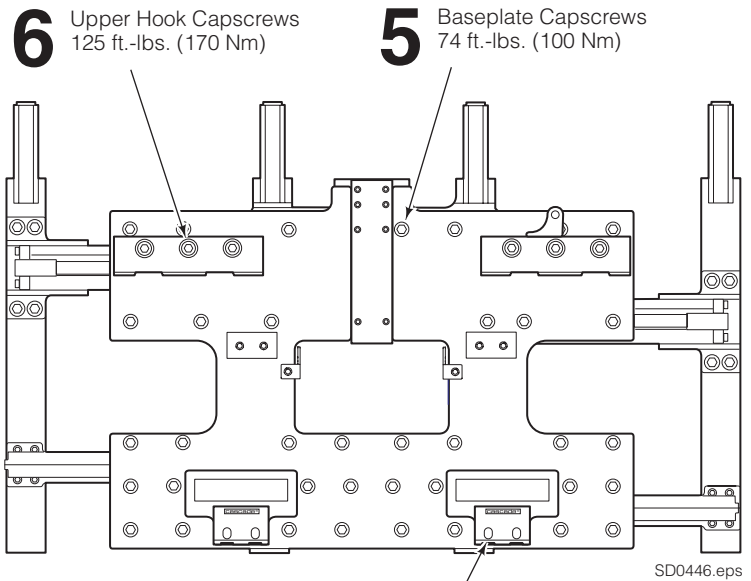

7 For installation, reverse the above procedures except for the following special instructions:

- Clean the upper and lower bearings and bearing contact surfaces.
- Locate the upper bearings in the anchor bracket cut-outs. Be careful not to install the bearings backwards.
- **Quick Disconnect Lower Hooks** - Remove the pins to raise the hooks and then install the pins. Leave .09 in. (2.5 mm) clearance for sideshifting.
- **Bolt-On Lower Hooks** - Install the lower hooks to the truck lower carriage bar leaving .09 in. (2.3 mm) clearance for sideshifting. Tighten the hook capscrews to a torque of 125 ft.-lbs. (170 Nm).

7 Lower Hook Capscrews
125 ft.-lbs. (170 Nm)

