



# Installation Instructions

---

## 35C, 55C and 80C Viewmast® II Dual Free-Lift Roller Masts

---

Field alterations may impair performance or capability and could result in loss of warranty. Consult Cascade for technical assistance and approval for any required modifications.

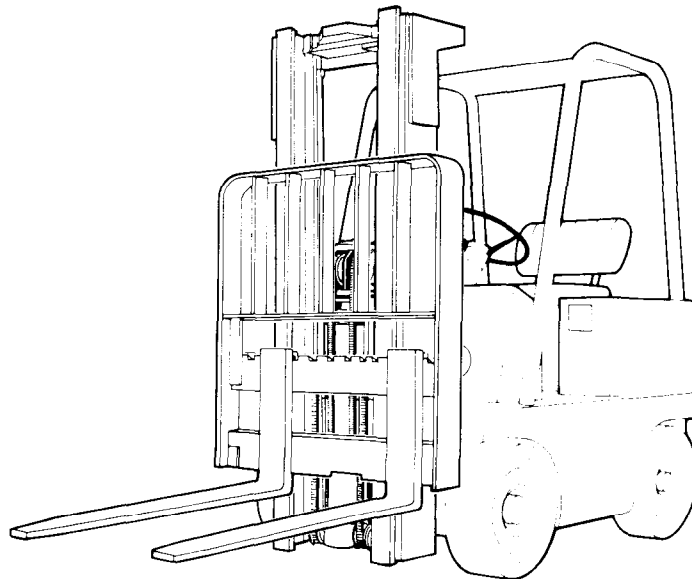

Manual Number 677735

---

**cascade**®

Cascade is a Registered Trademark of Cascade Corporation • Viewmast is a Trademark of Cascade Corporation.

# Contents

<b>Introduction</b> .....	i
<b>Truck System Requirements</b> .....	1
<b>Mounting Bracket Installation</b> .....	1
<b>Mast Installation</b> .....	3
<b>Operational Inspection and Adjustments</b> .....	3
Chain Inspection and Tension .....	3
Carriage Chain Adjustment .....	4
Hoist Chain Adjustment .....	4
Upright Channel Lubrication .....	4
<b>Periodic Maintenance</b> .....	5
Daily Inspection .....	5
100 Hour Inspection .....	5
500 Hour Inspection .....	6

## Introduction

This manual provides the installation instructions, periodic maintenance and adjustment procedures for the Cascade 35C, 55C and 80C Dual Lift Viewmast® II, full free-lift roller masts.

Viewmast® II masts provide **exceptional visibility** for the lift truck driver. The mast carriage and upright channels are **all-roller** mounted which provides smooth operation and long service life.

In any communication about your Cascade Viewmast® II, always refer to the mast catalog and serial number stamped on the mast nameplate. If the nameplate is missing, these numbers are also stamped on the left-hand side plate of the upper crossbar.

**If you have questions you need answered, call your nearest Cascade Service Department listed on the back cover.**

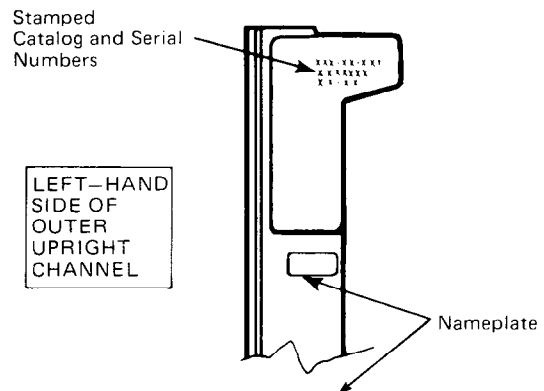

**WARNING:** Do not install a Viewmast® II on any truck with a capacity greater than the truck rated capacities shown below.

MODEL	TRUCK CAPACITY AT 24-INCH LOAD CENTER
35C	3500 pounds
55C	5500 pounds
80C	8000 pounds

2454g

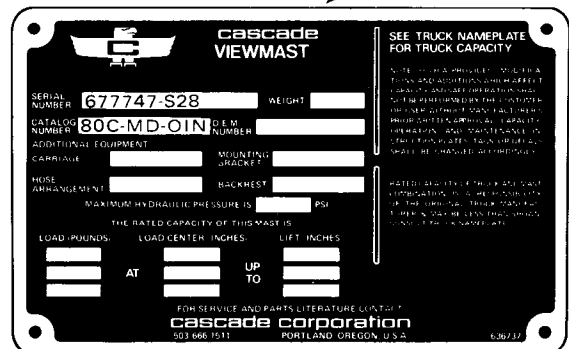

# Truck System Requirements

To achieve the maximum lifting capacity of the mast, the truck relief valve should be set to relieve at the pressure indicated in the chart below. This chart also indicates the hose and fitting size to use between the truck control valve and the mast cylinder hose.

Cascade Viewmast® II	Relief Pressure		Hose Sizes	Fitting Thread Sizes
	Min.	Max.		
35C Dual Lift	2200 PSI	2500 PSI	#8	3/4-16
55C Dual Lift				
80C Dual Lift				

2453g



**WARNING:** For proper truck stability or to prevent interference, tilt restriction may be required. Contact the truck manufacturer or one of the Cascade Service Departments listed on the back cover for the specific tilt modification required. Note: To achieve the proper tilt restriction, contact the lift truck manufacturer, or your truck service manual.

**IMPORTANT:** Standard Viewmast® II masts are compatible with SAE 10W petroleum base oil per Mil. Spec. MIL-0-5606 or MIL-02104 B only. Use of synthetic or aqueous base hydraulic oil is not recommended. If fire resistant hydraulic oil must be used, contact one of the Cascade Service Departments listed on the back cover.

# Mounting Bracket Installation

1. If it is necessary to install mounting brackets and crossmembers to fit your truck, consult with the nearest Cascade Service Department listed on the back cover. You must supply dimensions **A** through **F** shown in Figure 1. Failure to install the correct brackets and crossmembers can result in mast structural failure, bodily injury and loss of warranty.



**WARNING:** Failure to install the correct brackets and crossmembers can result in mast structural failure, bodily injury and loss of warranty.

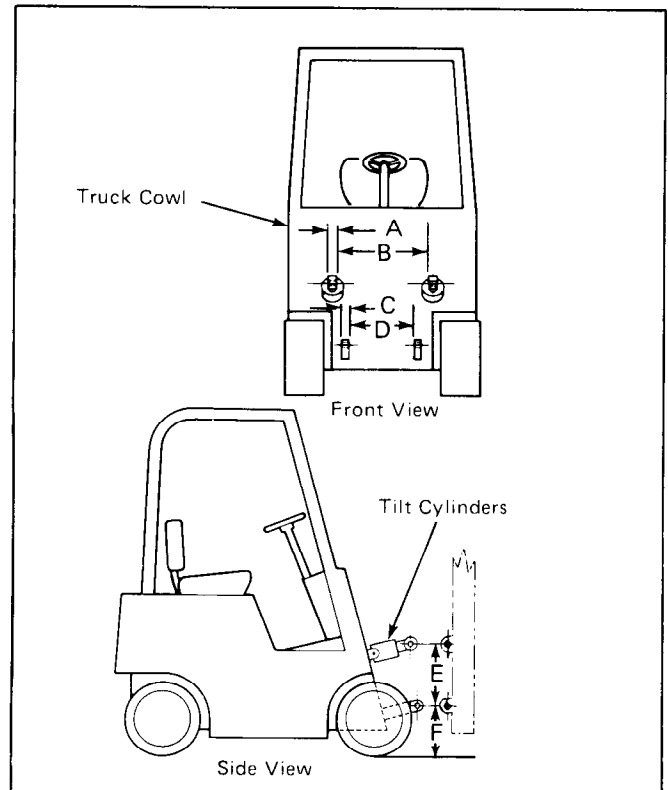



Figure 1. Determining Mounting Bracket and Crossmember Location.

# Mounting Bracket Installation

(Continued)

2. Mounting bracket and crossmember welding must be performed by a qualified welder only, using the following procedures:
  - a. Disassemble the outer channel from the mast prior to welding. Refer to the Dual Lift Service Manual part no. 677736 for disassembly procedures.
  - b. Clean all surfaces to be welded. Remove paint, oil, grease and other contaminants.
  - c. Locate the mounting brackets and crossmembers on the mast channels.  
Clamp in place with a "C" clamp. Protect the mast channel inner surfaces from weld splatter.
  - d. Use only FCAW (Flux Core Arc Weld) AWS E70T-1 1/16 in. diameter wire.
  - e. Preheat the upright and mounting brackets to 100° F. Monitor with a Tempstick (crayon). Do not weld in a drafty area.



**WARNING:** Weld areas that will be vertical seams when the mast is standing upright only. DO NOT WELD ANY HORIZONTAL SEAMS.

- f. Weld areas that will be vertical seams when the mast is standing upright only. DO NOT WELD ANY HORIZONTAL SEAMS. See Figure 2.
  - g. Weld the mounting brackets and crossmember with a .25 in. minimum fillet, holding a close arc. Weld in the flat position only. Do not oscillate or use a wash bead pattern.
  - h. **Weld each bracket in two passes. See Figure 2. Run the first weld from the bottom of the bracket to midpoint. Run the second weld from the top of the bracket to midpoint and overlap the first weld to eliminate arc craters. Let the weld slow cool.**
  - i. Remove slag and inspect the weld. The following defects are not allowed: undercut, overlap, stress cracks and porosity. Clean the weld area and repaint.
3. The measurement shown in Figure 3 should be taken after welding and cooling the mast. This dimension must be maintained for the uprights to slide together.
4. Reassemble the mast.

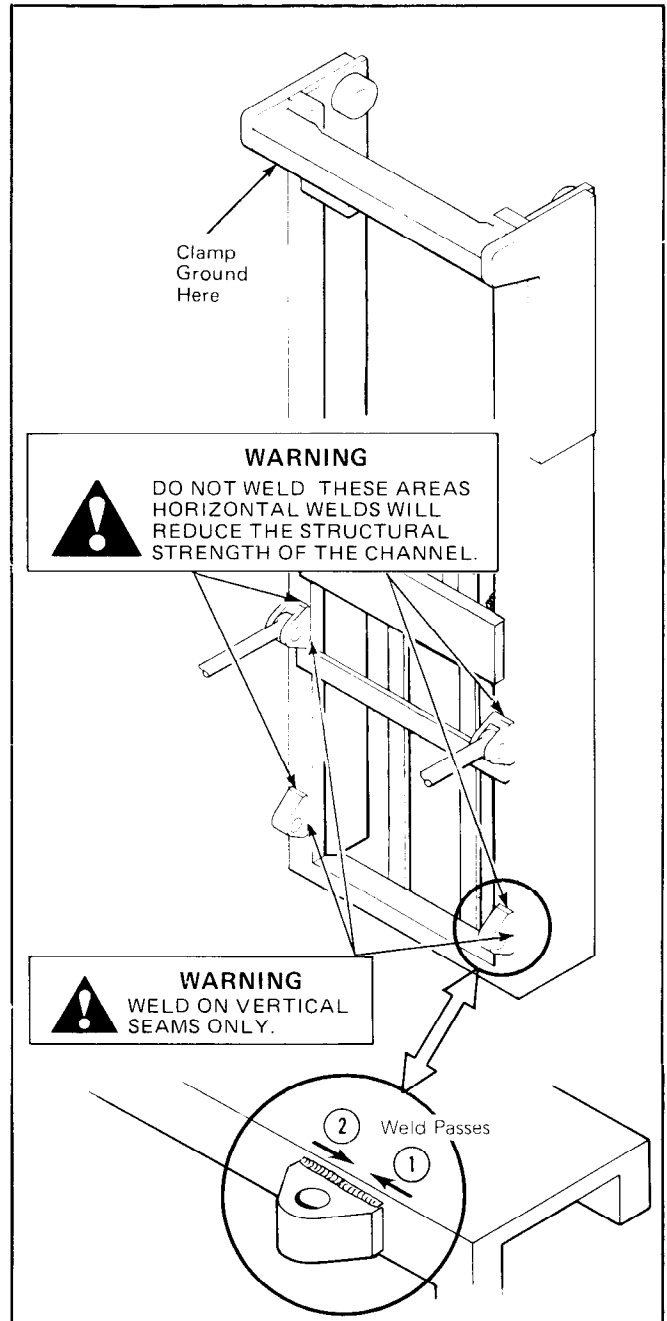

Figure 2. Mounting Brackets.

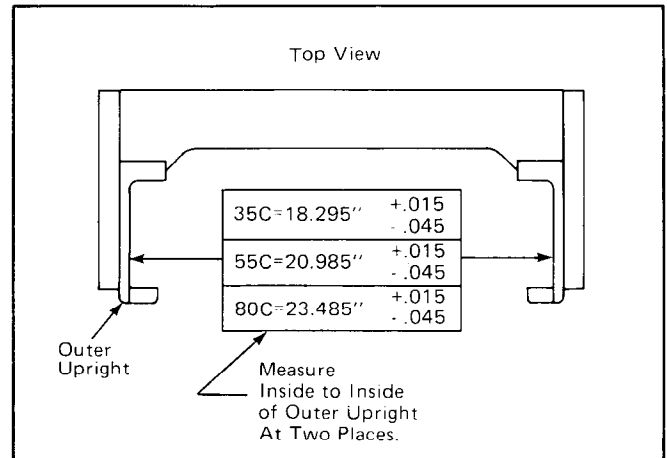

Figure 3. Dimensional Inspection.

## Mast Installation

1. Lubricate the bearing surfaces of the base and tilt cylinder mounting brackets with chassis grease.
2. Lift the mast using an overhead hoist with chains wrapped twice around the upper channel cross-members. Position the mast in place on the lift truck and secure the base mountings.

**IMPORTANT:** Prior to the connecting the tilt cylinders to the mast, make sure the cylinders "bottom" evenly. Adjust the tilt cylinders as required to prevent the mast from "racking" during tilting. Refer to your truck service manual for procedures.

3. Connect the tilt cylinders to the cylinder anchor brackets.
4. Before connecting the truck hose to the cylinder hose, actuate the truck control valve sufficiently to flush the truck hose with hydraulic oil.
5. Connect the lift truck hose to the cylinder hose on the mast. See Figure 4. The lift truck hose can be SAE 100 R2 or R9.

**NOTE:** Use as few fittings as possible and always use 45° elbows instead of 90° elbows. Keep the hose lengths to a minimum. Avoid sharp bends or pinch points when routing the hose.

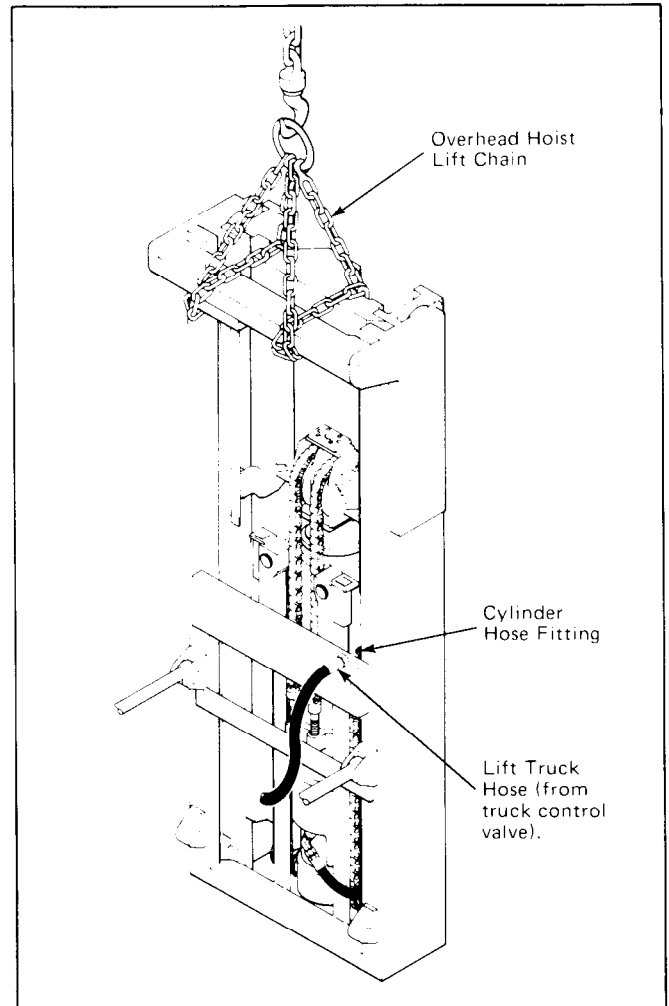

Figure 4. Mast Installation.

## Operational Inspection and Adjustments

**CAUTION:** The factory set adjustments may not be correct for your truck. Check each of the following before using the mast for the first time.

- Inspect the chains and check chain tension.
- Check the hoist and carriage chains for proper adjustment.

### Chain Inspection and Tension

The carriage and hoist chains have been factory lubricated using heat and pressure to force the lubricant thoroughly into the chain links. Avoid removal or contamination of this factory applied lubricant. **Do not wash, sand blast, etch, steam clean, or paint the chains for initial mast installation.**

# Operational Inspection and Adjustments (Continued)

The chains must be adjusted with equal tension to ensure proper load distribution and mast operation. To determine equal tension, extend the unloaded mast to put the chains under tension. Press the center of a strand of chain with your thumb. Then press at the same place on the other chain of the pair. Each chain in a pair should have equal "give". If they do not have equal tension, perform the Carriage or Hoist chain adjustments described below.

## Carriage Chain Adjustment

The carriage hoist chains should be adjusted so that when the unloaded mast is fully lowered, the carriage is positioned as shown in Figure 6.

To adjust the carriage chains:

1. Remove the cotter pins from the threaded chain anchors, located on the inner upright crossmember directly behind the cylinder. See Figure 5.
2. Adjust one chain to achieve the correct carriage position when fully lowered, as shown in Figure 6.
3. Adjust the other chain to achieve equal chain tension.
4. Install new cotter pins to the chain anchors.

## Hoist Chain Adjustment

The hoist chains should be adjusted so that when the unloaded mast is fully lowered, the upright channels and cylinder are even with each other at the bottom within 1/8 inch.

To adjust the hoist chains:

1. Raise the carriage to expose the threaded hoist chain anchors located on the front side of the inner upright crossmember on each side of the cylinder. Remove the cotter pins from the chain anchors. See Figure 5.
2. Adjust one chain to achieve the correct upright position when fully lowered, as shown in Figure 7.
3. Adjust the other chain to achieve equal chain tension.
4. Install the cotter pins to the chain anchors.

## Upright Channel Lubrication

Lubricate the full length of each upright channel with chassis lube or Kendall SR-8X (Cascade Part No. 599474) as shown in Figure 8.

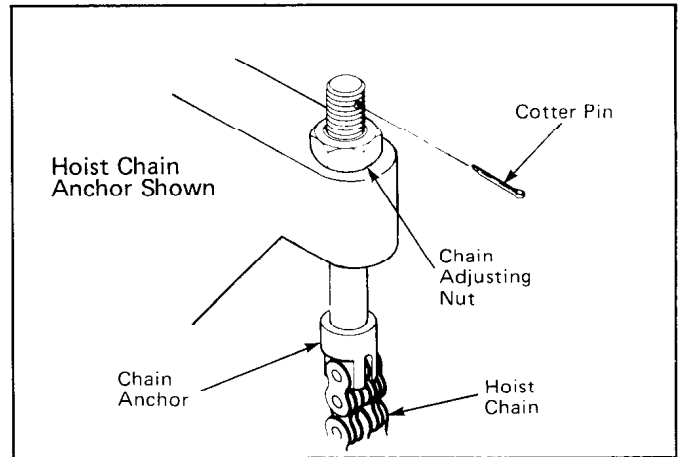

Figure 5. Chain Anchor.

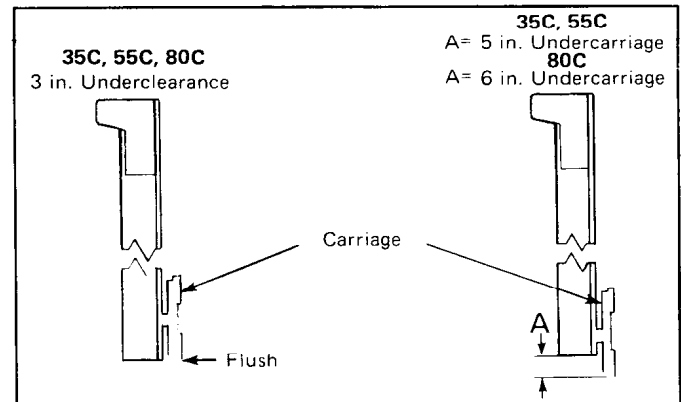

Figure 6. Carriage Adjustment.

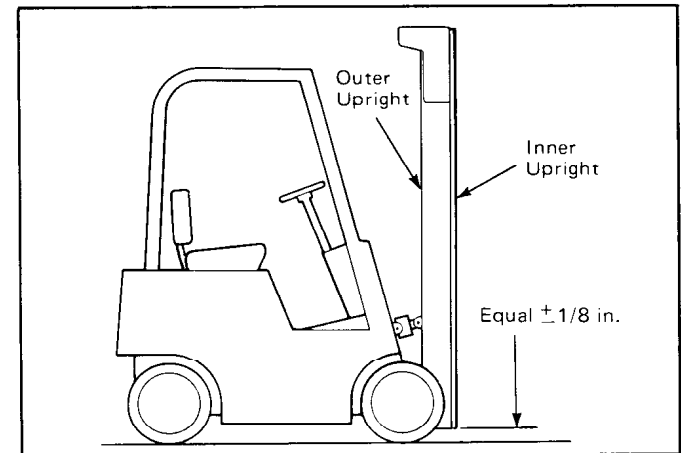

Figure 7. Upright Adjustment.

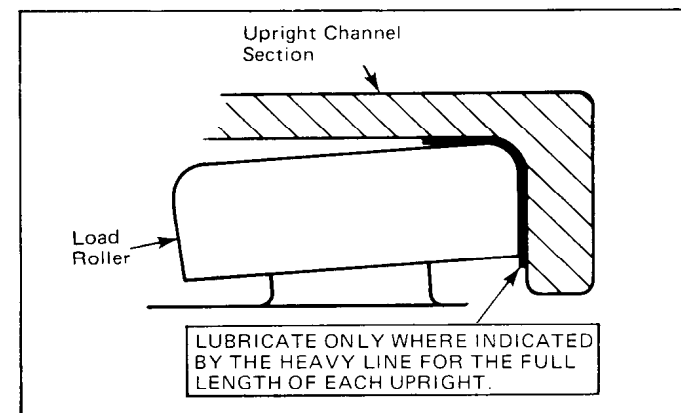

Figure 8. Upright Channel Lubrication.

# Periodic Maintenance

For proper operation and an extended service life, your Viewmast® II should be inspected and serviced regularly as part of your normal lift truck maintenance schedule according to the following outlines.

The recommended intervals are for masts operating under normal conditions. If the mast is operating in severe conditions or very corrosive atmospheres, the inspections should be performed more frequently.



**WARNING:** Never work on the mast with a load on the forks or attachment, or while anyone is near the lift truck control handles.

## Daily Inspection

Perform the following at the beginning of each work shift:

1. Extend the carriage a few inches off the ground and make sure the carriage chains are under equal tension.
2. Extend the mast to its full height to make sure the hoist cylinder sequences properly. The outer plunger should fully extend, then the inner plunger should fully extend. Make sure the mast channels and carriage extend freely without binding.
3. While the mast is extended, inspect the upright channels for proper lubrication.
4. While the mast is extended, make sure the hoist chains are under equal tension.
5. Lower the mast and make sure the cylinder sequences properly. The inner plunger should lower first, then the outer plunger should lower freely without binding.
6. Make sure the cylinder hose is not twisted and travels smoothly in the hose guide. Check the hose to be sure it is not scuffing. Minor adjustments to the hose can be made by loosening the bulkhead elbow fitting located on the mast channel. Twist the hose slightly to fit in the guide.
7. Be sure the urethane cushions at the top of the crosshead and outer upright are not flattened or distorted.

## 100 Hour Inspection

After each 100 hours of lift truck operation, and in addition to the daily inspection:

1. Inspect and lubricate the full length of each pair of hoist chains with SAE 30 oil.

**CAUTION:** The chains must be coated with a film of lubricant at all times.

2. After the first 100 hours and every 500 hours thereafter, check both pairs of hoist chains for wear and stretch.
  - Check for rust and corrosion.
  - Check for cracked side plates. If you find cracked side plates, replace **both** chains.
  - Check for tight joints. If tight joints are caused by rust or corrosion, loosen them with SAE 40 oil or penetrating oil. If they cannot be loosened or if tight joints are caused by bent pins or plates or by peened plate edges, replace **both** chains.

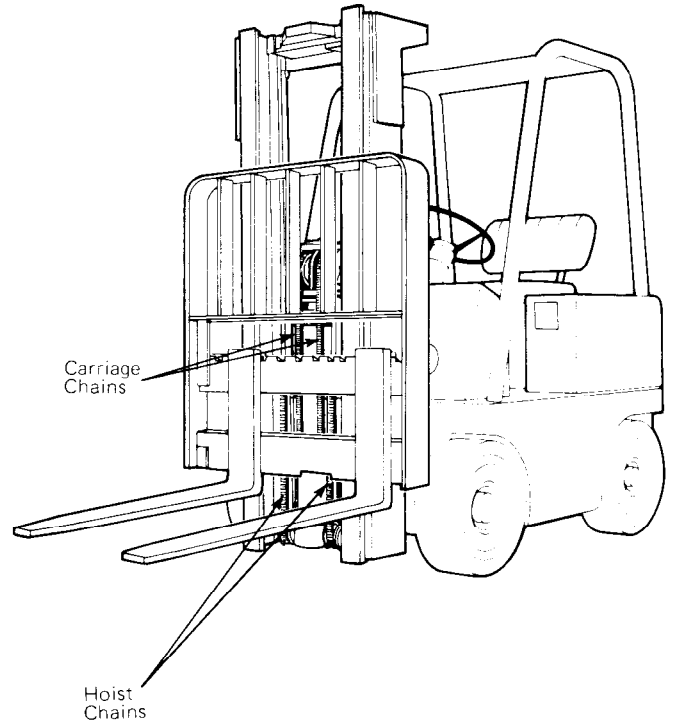

# Periodic Maintenance

## 100 Hour Inspection (Continued)

- Check for protruding or turned pins. If damage is evident, replace **both** chains.
- Check for chain side wear. If pins and outside plates show signs of wear, check for misalignment of sheaves, anchors, or other components. Correct the misalignment. If wear is excessive, replace **both** chains.
- Check for worn, broken or misaligned chain anchors. Replace or adjust as required.

If inspection indicates the chains should be replaced, perform a complete overhaul of the mast as outlined in the Dual Lift Service Manual part no. 677736.

## Measuring Chain Stretch

If the hoist chains stretch beyond the recommended amount, they should be replaced in pairs. Chain stretch can be measured with the chain wear scale part no. 661923 included with the Customer User Kit. Measure the chains as shown in Figure 9 according to the instructions printed on the chain wear scale, without a load on the carriage.

- To measure the carriage hoist chains, raise the carriage a few inches off the ground to put tension on the chains.
- To measure the hoist chains, the mast must be extended sufficiently to expose the chains.

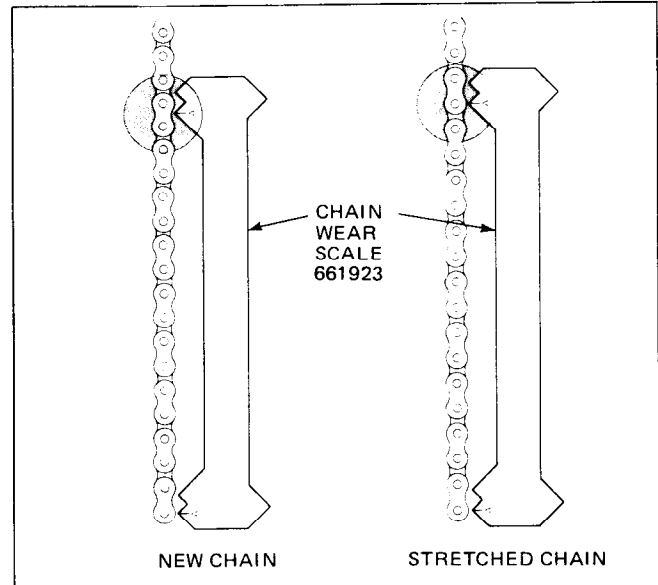

Figure 9. Checking Chain Stretch.

## 500 Hour Inspection

Each pair of load rollers on the uprights and carriage should be shimmed so that a total clearance no greater than 0.06 inch occurs at the tightest point throughout the travel of the member. See Figure 10.

- To check the clearance, pry between the upright and load roller as shown so that the opposite load roller is tight against the upright. Measure the clearance for the pair of load rollers at the XXX shown. Repeat for each pair of rollers.
- If additional shims are required, refer to the Dual Lift Service Manual part no. 677736.

The pair of crosshead guides should be shimmed so that a total clearance no greater than 0.09 inch occurs at the tightest point throughout the travel of the guides in the inner upright guide channels. See Figure 10.

- Push the crosshead to one side and measure the gap between the opposite crosshead guide and guide channel.
- If additional shims are required refer to the Dual Lift Service Manual part no. 677736.

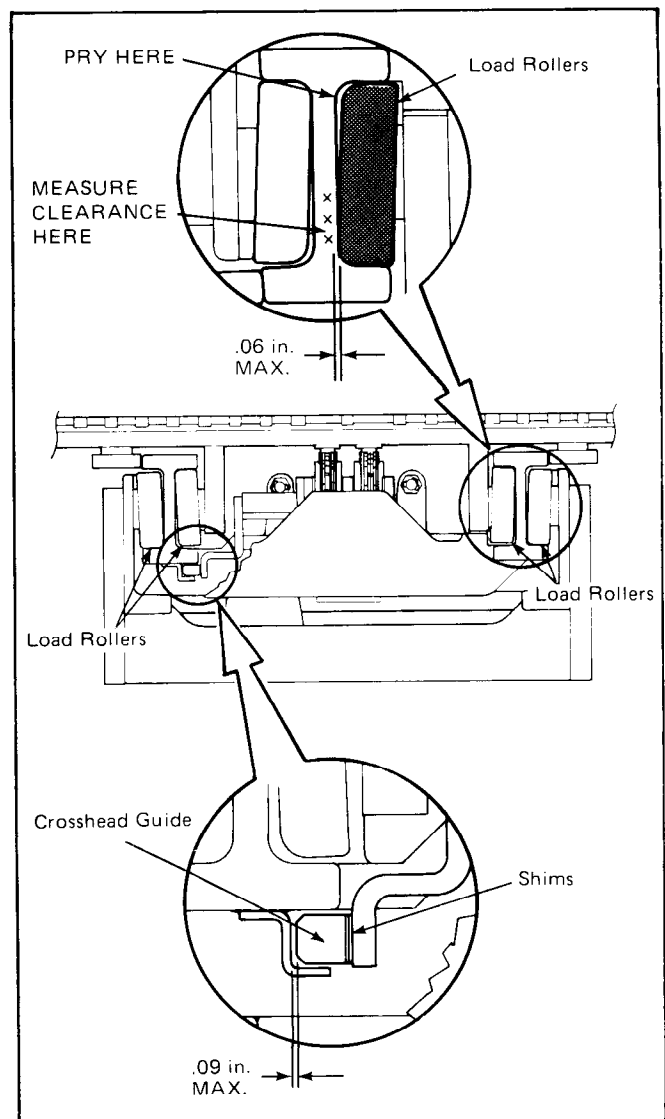

Figure 10. Load Roller and Crosshead Clearances.

**Do you have questions you need answered right now?** Call your nearest Cascade Service Department.

**Cascade Corporation**  
P.O. Box 20187  
2201 N.E. 201st Ave.  
Troutdale, OR 97060  
Tel.: 503/666-1518  
800-227-2233 (Toll Free)  
Telex: 590480  
Cable: Cascade Ptl  
FAX: 1-503-665-0301

**Cascade Scandinavia  
Hydraulik A.B.**  
Muskötgatan 17-(E.8-9)  
252 55 Helsingborg  
Sweden  
Tel.: 042-151135  
Telex: 72565 caschbg s

**Cascade Hydraulics Ltd.**  
7615 Kimbel Street  
Mississauga, Ontario  
Canada L5S-1A8  
Tel: 416/677-9695  
Direct Parts Line:  
416/677-9686  
416/677-9684  
Tel/Ac: 06-968715

**Cascade Japan Ltd.**  
4-1, 1-Chome,  
Shin Senri Higashimachi  
Toyonaka, Osaka 565  
Japan  
Tel.: 06-835-2900  
Tel/Ac: 781-5287115 Cascade J  
Cable: Cascadecfe, Osaka  
FAX: 011-816-835-2905

**Cascade N.V.  
European Headquarters**  
P.O. Box 50086  
1305 AB Almere-Haven  
Achterwerf 240  
1357 CB Almere-Haven  
The Netherlands  
Tel.: 03240-92911  
Telex: 40838 case nl  
FAX: 011-31-3240-92286

**Cascade France S.A.R.L.**  
11, rue Jean Charcot  
Zone Industrielle Sud  
B.P. 22  
91421 Morangis Cedex  
France  
Tel.: (1)69091139  
Telex: cascade 690016f

**Cascade Materials Handling  
(Aust.) Pty. Ltd.  
(Incorporated in N.S.W.)**  
121 Long Street  
Smithfield, N.S.W. 2164  
Australia  
Tel.: 02-604-6222  
Te/Ac: (790)24302  
Cable: Cascaus  
FAX: 011-61-2-609-2742

**Cascade N.V.  
Benelux Sales and Service**  
P.O. Box 170  
1110 AD Diemen  
Weesperstratt 110  
1112 AP Diemen  
The Netherlands  
Tel.: 020-906411  
Telex: 14495 casc nl

**Cascade Hispania S.A.**  
Avenida De La Fabregada, 7  
Hospitalet De Llobregat  
Barcelona  
Spain  
Tel.: 93-3355158  
Telex: 54018 casc e

**Cascade Materials Handling  
(Aust.) Pty. Ltd.**  
44E Winterton Road  
Clayton, Victoria 3168  
Australia  
Tel.: 03-543-4344  
Cable: Casmel

**Cascade GmbH**  
Klosterhofweg 52  
4050 Mönchengladbach 3  
B.R. Deutschland  
Tel.: 02166-602091  
Telex: 852812 casc d

**Cascade (UK) Ltd.**  
15, Orgreave Crescent  
Dore House Industrial Estate  
Handsworth  
Sheffield S13 9NQ  
England  
Tel.: 0742-697524/5/6/7  
Telex: 547254 cascsh g

**Cascade (Africa) Pty. Ltd.**  
P.O. Box 625  
15 Power Street  
Isando 1600  
South Africa  
Tel.: 011-974-5611/2/3/4/5  
Telex: 4-29718 S.A.

