



Control Clamp Force Automatically and Reduce Product Damage

APPLICATIONS

Excessive clamp force caused by too much hydraulic pressure is one of the most common causes of damage to paper rolls. Mechanical 3-position relief valves are under-utilized or primarily left on the high setting. HFC (Hydraulic Force Control) solves these issues by automatically adjusting clamp force. HFC is a hydraulically controlled automatic clamp force system that changes the clamp force proportional to the load weight. It works by continually sensing the hydraulic pressure necessary to lift the load and adjusts clamping pressure as the weight of the load increases or decreases. The system operates without any special actions on the part of the driver.

BENEFITS

- No need to change driver habits.
- Driver can use normal operating procedure: Close clamp arms on load and then hoist load off ground.
- Hydraulics can be feathered to allow driver to control clamp force on extremely small, light loads.
- Quick Installation only requires tapping into the Hoist, Clamp and Open lines.
- Low maintenance system does not require an accumulator to charge the system (which can lose charge).

FEATURES

- Conveniently sized hydraulic valves mount easily onto the cowl of lift truck.
- Infinite adjustment of clamp force in the capacity range of the attachment. The system adjusts clamp force proportional to the roll weight.
- When installed with the equalizing valve, the clamp force remains constant between Freelift and Mainlift. Accomplished with the use of a switch that determines if the clamp is in Freelift or Mainlift.
- HFC is flexible, allowing easy adjustment for:
 - All clamp force settings
 - Maximum pressure
 - Balancing clamp force between Freelift and Mainlift
 - Balancing clamp force when the size of the truck and clamp are not ideally matched.
- Compatible with Split and Solid Arm Clamps.



*Prevent
over clamping
by controlling
clamp force
automatically.*

HFC MODELS

HFC KIT FOR FREE LIFT MAST APPLICATIONS

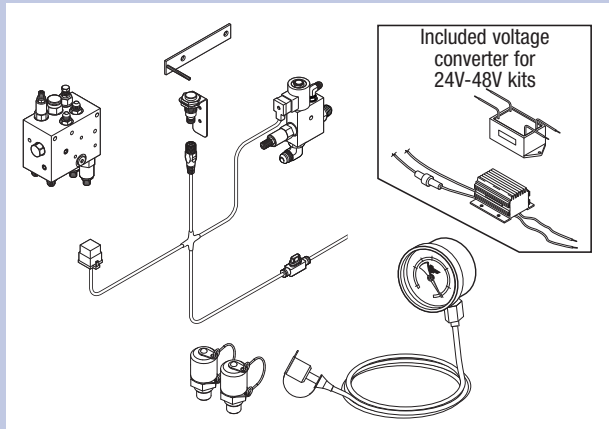

For use on 2 Stage Full Free Lift (Duplex) and 3 Stage Full Free Lift (Triplex) mast applications. Includes equalization switch which equalizes system pressure for improved accuracy.

HFC KIT FOR LIMITED FREE LIFT MAST APPLICATIONS

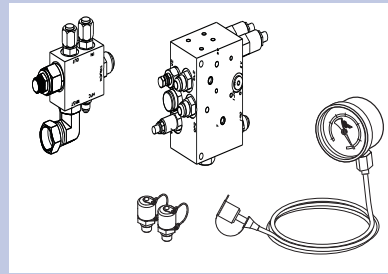

For use on 2 Stage Limited Free Lift (Simplex) mast applications.

OPTIONAL ARM SPEED OVERDRIVE SYSTEM

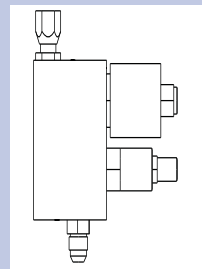

System drives the arms to close at full speed (used in applications where very low clamping pressure is required, resulting in lower arm speed).

Conveniently attaches to the main HFC valve for easy installation.

RECOMMENDED DAMAGE REDUCTION OPTIONS

Load Cushion™



Hoist System Accumulator that absorbs shocks and reduces the clamp force required to handle the load. Available in one pint and one quart sizes.

Split-Arm



Allows secure handling of two stacked rolls of different diameters. Patented hydraulic circuit allows clamping of one roll with minimum top arm movement.

Swing Frame



Swing Frame models offer you the optimum in roll handling speed and capability. The lateral 'swing' or sideshifting function adds an extra dimension of flexibility to the clamp's breakout and tight stacking capabilities.

Two-Way Tilt Control

Electronic Rotational Control

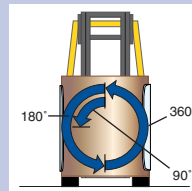

Provides 90° (bilge) and 180° stops during 360° clamp rotation, which automatically aligns pad to roll.

Tilt Control

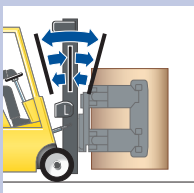

Automatically controls the angle of the mast and attachment, aligning pad with the load.

Application Specific Pads



The correct pad is provided depending on the type of paper being handled. Use of the correct pad allows clamp pressure to be minimized.