



*A Single-Double
Pallet Handler
Specifically
Designed for
the Beverage
Industry*

Fast Loading of Beverage Trailers

APPLICATIONS

Designed specifically to handle International or Euro Pallets commonly used in the beverage industry. Cascade's Single-Double Pallet Handler allows single pallet handling without protrusion outside the truck profile. Spreading the forks hydraulically allows handling of two pallets side by side. Sideshifting provides added flexibility for aligning forks or pallets in tight areas.

FEATURES

- Superior visibility through and over the frame for damage free handling at all stacking heights
- All steel frame for increased overall durability, eliminating flexing
- Easy access cylinders can be resealed without removing for quick servicing
- Bolt-on Interchangeable forks for low service cost
- Full-length, fully enclosed wrap around UHMW plastic bearings provide maximum strength and full bearing support, greatly reducing wear on bearing surface
- Parabolic fork heel increases longevity in this normally high-wear area
- Dual class 2 and 3 mountings, easily field converted
- Inner forks mounted on a chrome pin for greater inner fork stability
- Adjustable fork set spread for ability to handle Euro or international pallets (560 to 640)

OPTIONS

- Various load backrest configuration heights, fork lengths and sections
- Various fork set spreads and opening ranges
- Quick-disconnect lower hooks
- Drop shank forks—forks are lowered relative to the attachment frame
- Independent fork set control—allows moving left or right fork set independent of the opposite fork set
- Non-Sideshifting models available



BEVERAGE INDUSTRY SINGLE-DOUBLE PALLET HANDLER

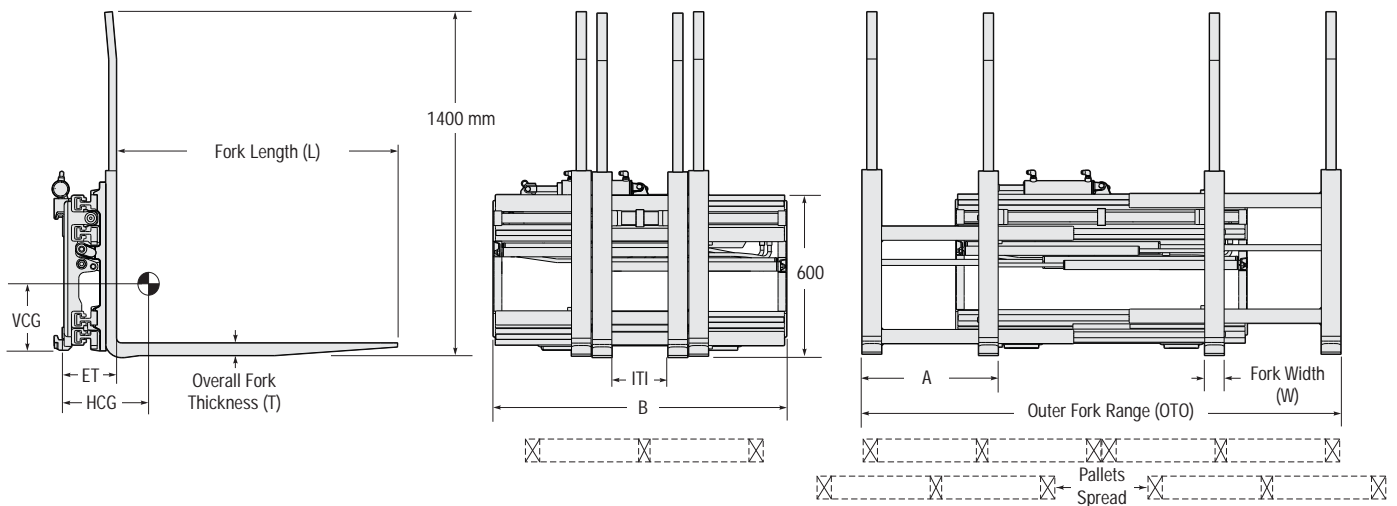

Beverage Industry—Sideshifting

Catalogue Order No.	Capacity @ 600 mm Load Centre kg	Opening Range (mm) OTO	In to In Closed (mm) ITI	Frame width (mm) B	Fork set spread (mm) A	Fork size (mm) LxWxT	Minimum Truck Carriage Width (mm)	Effective Thickness (mm) ET	Horizontal Centre Of Gravity (mm) HCG	Vertical Centre of Gravity (mm) VCG	Weight kg	Mounting Class ISO 2328
General multi load handler - for Euro pallets 1200x800mm												
28G-FDS-B611	2800	560-1970	230	1200	560	1150x80x50	980	223	263	204	613	3
32G-FDS-B601	3200	560-1970	230	1200	560	1150x80x60	980	233	283	192	668	3
General multi load handler - for international pallets 1200x1000mm												
28G-FDS-B610	2800	660-2040	330	1200	640	1150x80x50	980	223	262	205	618	3
32G-FDS-B600	3200	660-2040	330	1200	640	1150x80x60	980	233	281	193	672	3

- ▶ The outer fork tines are 5 mm higher than the inner fork tines
- ▶ 200 mm total sideshift
- ▶ Limited to forks up to 1520 mm in length.

- ▶ For longer forks please see FQS models.
- ▶ Right hand termination standard, left hand termination available at no charge.

HYDRAULIC FLOW AND PRESSURE (L/MIN.)

Minimum	Recommended	Maximum	Operating Pressure
15	27	27	200 BAR

INSTALLATION KITS

Model	Catalog Order No.
Class 3	6072234

HYDRAULIC FUNCTIONS

Hydraulic Functions	Truck Auxiliary Valves Required
2	2

CONVERSION KIT

Models	Conversion	Catalog Order No.
28G	Class 2 to 3	6072573
28G	Class 3 to 2	6072574