



*Designed
with great
visibility, easier
maintenance,
and superior
durability.*

Move more loads faster, minimize damage and stay competitive.

APPLICATIONS

Designed for any application using pallets or containers to load trucks, Cascade's Single-Double Pallet Handler allows single pallet handling without protrusion outside the truck profile. Spreading the forks hydraulically allows handling of two pallets side by side. Sideshifting provides added flexibility for aligning forks or pallets in tight areas.

FEATURES

- Superior visibility through and over the frame for damage free handling at all stacking heights
- All steel frame for increased overall durability, eliminating flexing
- Easy access cylinders can be resealed without removing for quick servicing
- Bolt-on Interchangeable forks for low service cost
- Full-length, fully enclosed wrap around UHMW plastic bearings provide maximum strength and full bearing support, greatly reducing wear on bearing surface
- Parabolic fork heel increases longevity in this normally high-wear area
- Inner forks mounted on a chrome pin for greater inner fork stability
- Adjustable fork set spread for ability to handle Euro or international pallets (560 to 640)

OPTIONS

- Various load backrest configuration heights, fork lengths and sections
- Various fork set spreads and opening ranges
- Quick-disconnect lower hooks
- Drop shank forks—forks are lowered relative to the attachment frame
- Independent fork set control—allows moving left or right fork set independent of the opposite fork set
- Non-Sideshifting models available
- Lower sideshift rollers



G2 SINGLE-DOUBLE PALLET HANDLER

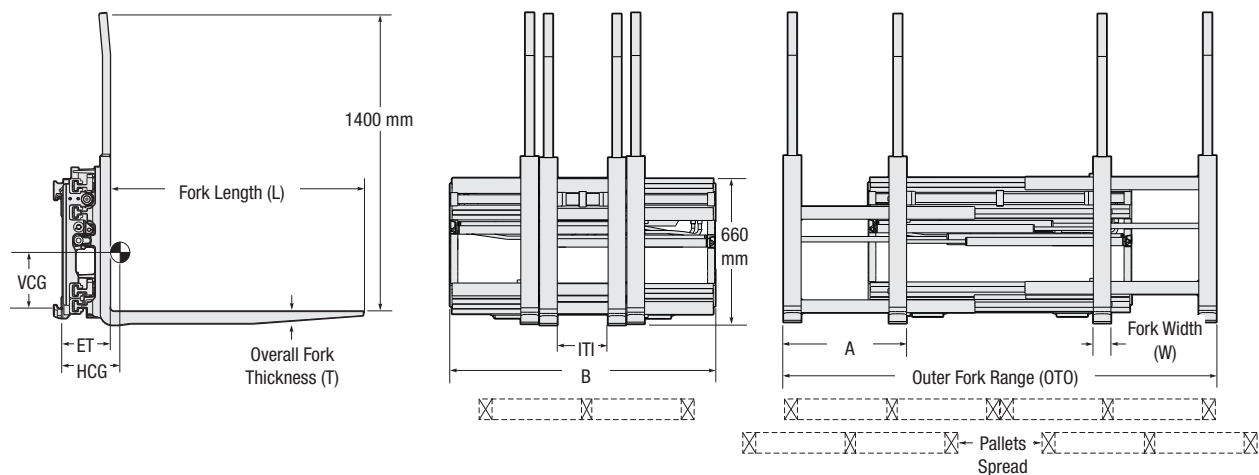

| Catalogue Order No. | Capacity @ Load Centre kg@mm | Opening Range (mm) OTO | In to In Closed (mm) ITI | Frame width (mm) B | Fork set spread (mm) A | Fork size (mm) LxWxT | Minimum Truck Carriage Width ① (mm) | Effective Thickness (mm) ET | Horizontal Centre Of Gravity (mm) HCG | Vertical Centre of Gravity (mm) VCG | Weight kg | Mounting Class ISO 2328 | Backrest Height |
|---|---------------------------------|---------------------------|-----------------------------|-----------------------|---------------------------|-------------------------|--|--------------------------------|--|--|--------------|----------------------------|-----------------|
| General multi load handler - for Euro pallets 1200x800mm | | | | | | | | | | | | | |
| 22G2-FDS-A501 | 2200@600 | 560-1970 | 230 | 1200 | 560 | 1150X80X40 | 980 | 229 | 234 | 266 | 515 | 2 | 1400 |
| 25G2-FDS-A501 | 2500@600 | 560-1970 | 230 | 1200 | 560 | 1150X80X45 | 980 | 234 | 245 | 260 | 530 | 2 | 1400 |
| 25G2-FDS-B501 | 2500@600 | 560-1970 | 230 | 1200 | 560 | 1150X80X45 | 980 | 238 | 244 | 267 | 538 | 3 | 1400 |
| 28G2-FDS-B511 | 2800@600 | 560-1970 | 230 | 1200 | 560 | 1150X80X50 | 980 | 256 | 258 | 265 | 576 | 3 | 1400 |
| 32G2-FDS-B501 | 3200@600 | 560-1970 | 230 | 1200 | 560 | 1150X80X60 | 980 | 266 | 257 | 280 | 612 | 3 | 1400 |
| General multi load handler - for international pallets 1200x1000mm | | | | | | | | | | | | | |
| 22G2-FDS-A500 | 2200@600 | 660-2040 | 330 | 1200 | 640 | 1150X80X40 | 980 | 229 | 233 | 266 | 519 | 2 | 1400 |
| 25G2-FDS-A500 | 2500@600 | 660-2040 | 330 | 1200 | 640 | 1150X80X45 | 980 | 234 | 244 | 260 | 534 | 2 | 1400 |
| 25G2-FDS-B500 | 2500@600 | 660-2040 | 330 | 1200 | 640 | 1150X80X45 | 980 | 238 | 243 | 268 | 542 | 3 | 1400 |
| 28G2-FDS-B510 | 2800@600 | 660-2040 | 330 | 1200 | 640 | 1150X80X50 | 980 | 256 | 257 | 266 | 580 | 3 | 1400 |
| 32G2-FDS-B500 | 3200@600 | 660-2040 | 330 | 1200 | 640 | 1150X80X60 | 980 | 266 | 256 | 271 | 616 | 3 | 1400 |
| Fruit Auction multi load handler - for auction pallets 1200x1000mm | | | | | | | | | | | | | |
| 25G2-FDS-A520 | 2500@600 | 815-2210 | 485 | 1150 | 710 | 1000x80x45 | 980 | 234 | 218 | 273 | 518 | 2 | 1400 |
| 25G2-FDS-B520 | 2500@600 | 815-2210 | 485 | 1150 | 710 | 1000x80x45 | 980 | 238 | 217 | 279 | 526 | 3 | 1400 |
| 25G2-FDS-A521 | 2500@600 | 700-2095 | 370 | 1150 | 685 | 1000x80x45 | 980 | 234 | 218 | 273 | 515 | 2 | 1400 |
| 25G2-FDS-B521 | 2500@600 | 700-2095 | 370 | 1150 | 685 | 1000x80x45 | 980 | 238 | 217 | 280 | 523 | 3 | 1400 |

① For narrower carriage widths, Consult Cascade.

- ▶ FDS units are limited to forks up to 1520 mm in length.
- ▶ For longer forks please see FQS models.
- ▶ Other fork lengths available.
- ▶ The outer fork tines are 5 mm higher than the inner fork tines.
- ▶ UHMW Polyethylene lower sideshift bearings are standard, for optional lower sideshift rollers on G2 models consult Cascade.

▶ 200 mm total sideshift.

▶ Right hand termination standard, left hand termination available at no charge.

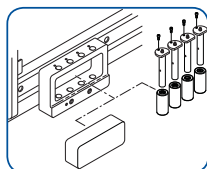

HYDRAULIC FLOW AND PRESSURE

| Minimum | Recommended | Maximum | Operating Pressure |
|----------|-------------|----------|--------------------|
| 15 l/min | 27 l/min | 27 l/min | 200 BAR |

HYDRAULIC FUNCTIONS

| Hydraulic Functions | Truck Auxiliary Valves Required |
|---------------------|---------------------------------|
| 2 | 2 |