



## Ideal for loading and unloading trailers and containers.

### APPLICATIONS

The Cascade 70F Bale Clamp efficiently handles cotton, wool and synthetic textile bales, corrugated, newsprint, rag, hay, and metal & paper scrap bales.

The valve is mounted behind the frame, resulting in a low frame height which provides visibility over the frame and makes the 70F clamp ideal for loading and unloading trailers and overseas containers.

### FEATURES

- Rugged I-beam frame for durability and visibility
- Thin arm profile for “knifing” between tightly stacked bales
- Regenerative hydraulic circuit for fast arm speed
- One-piece frame bearings for superior durability and serviceability
- Maximum bearing surface for longer bearing life
- Bi-directional pressure relief valve for clamp and sideshift circuits

### OPTIONS

- Independent arm control
- Special pressure relief configurations
- Quick-change lower hooks
- Non-standard frame widths and opening ranges
- Customized bale arms and sizes



*The strength, visibility and speed to handle almost any baled product.*

# 70F BALE CLAMP

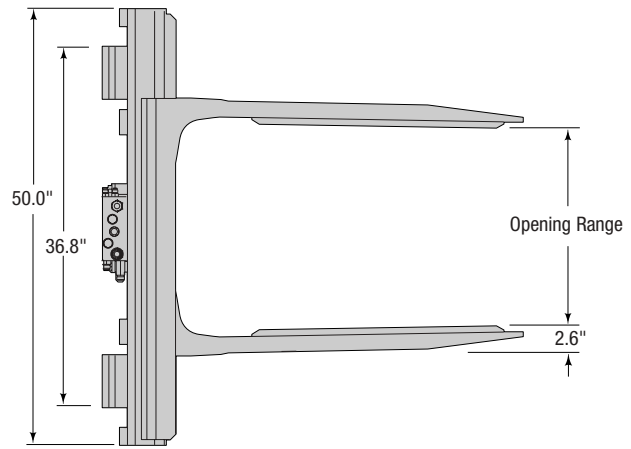
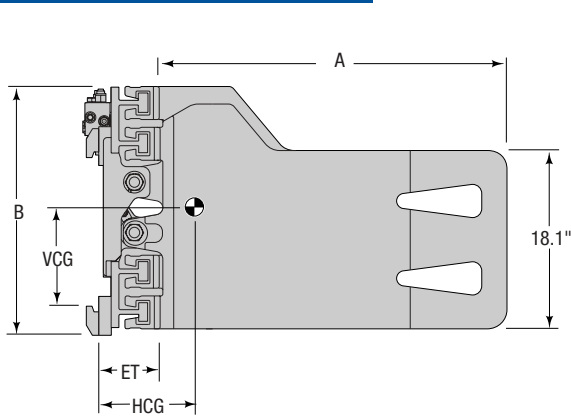

Capacity @ 24" (600 mm) Load Center		Opening Range	Catalog Order No.	Mtg. Class	Arm Length	Weight		Effective Thickness	Horizontal Ctr. of Gravity	Vertical Ctr. of Gravity	Overall Height
lbs	kg					lbs	kg				
<b>Non-Sideshifting</b> <sup>①</sup>											
7,000	3,180	22.0"-82.7"	<b>70F-BCB-51B</b>	III	47.2"	1,825	829	6.5"	12.7"	10.7"	28.5"
7,000	3,180	22.0"-82.7"	<b>70F-BCB-51C</b>	IV	47.2"	1,835	833	6.9"	12.7"	10.7"	32.9"
7,000	3,180	22.0"-82.7"	<b>70F-BCB-52B</b>	III	53.1"	1,920	872	6.5"	14.4"	10.6"	28.5"
7,000	3,180	22.0"-82.7"	<b>70F-BCB-52C</b>	IV	53.1"	1,930	876	6.9"	14.4"	10.6"	32.9"
7,000	3,180	22.0"-82.7"	<b>70F-BCB-53B</b>	III	60.2"	2,040	926	6.5"	16.3"	10.4"	28.5"
7,000	3,180	22.0"-82.7"	<b>70F-BCB-53C</b>	IV	60.2"	2,050	931	6.9"	16.3"	10.4"	32.9"
<b>Sideshifting</b> <sup>①</sup>											
7000	3,180	22.0"-82.7"	<b>70F-BCS-61B</b>	III	47.2"	1,825	829	6.5"	12.7"	10.7"	28.5"
7000	3,180	22.0"-82.7"	<b>70F-BCS-61C</b>	IV	47.2"	1,835	833	6.9"	12.7"	10.7"	32.9"
7000	3,180	22.0"-82.7"	<b>70F-BCS-62B</b>	III	53.1"	1,920	872	6.5"	14.4"	10.6"	28.5"
7000	3,180	22.0"-82.7"	<b>70F-BCS-62C</b>	IV	53.1"	1,930	876	6.9"	14.4"	10.6"	32.9"
7000	3,180	22.0"-82.7"	<b>70F-BCS-63B</b>	III	60.2"	2,040	926	6.5"	16.3"	10.4"	28.5"
7000	3,180	22.0"-82.7"	<b>70F-BCS-63C</b>	IV	60.2"	2,050	931	6.9"	16.3"	10.4"	32.9"

① Integral arms.

## INSTALLATION KIT

Model	Catalog Order No.
Non-Sideshifting	659245
Sideshifting	672442

## HYDRAULIC FLOW

Minimum	Recommended	Maximum	Maximum Pressure
10 GPM	14 GPM	17 GPM	2,600 PSI

## HYDRAULIC FUNCTIONS

Model	Hydraulic Functions	Truck Auxiliary Valves Required
Sideshifting	2	2
Non-Sideshifting	1	1